

ROTATION HANDWHEEL FOR PRIMARY AXIS WITH STANDARD LOW BACKLASH NON-BACKDRIVING GEARBOX: 216:1 RATIO (60:1 GEARBOX X 3.61:1 SLEWING RING)

3.00 MAX CG OFFSET (2.69" MAX TO MAINTAIN EASY CRANK)

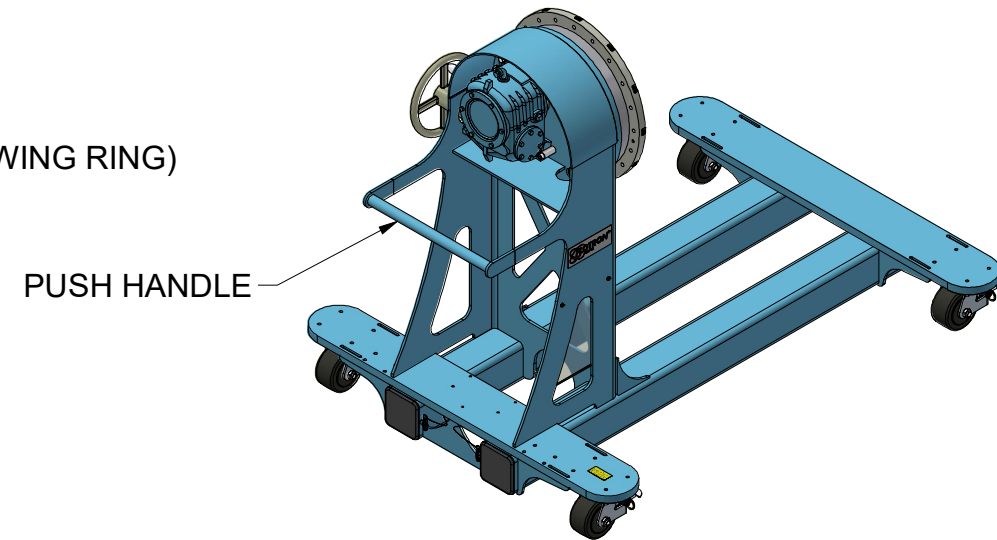

PUSH HANDLE

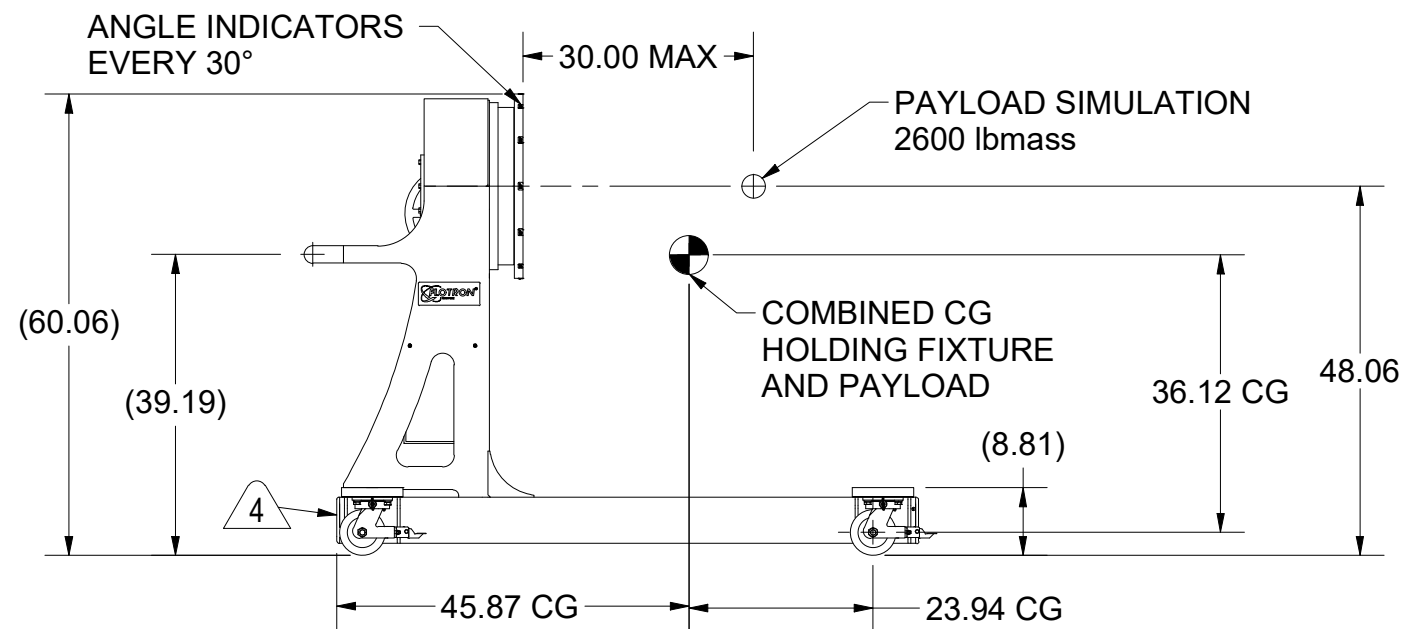

COMBINED CG HOLDING FIXTURE AND PAYLOAD

R39.20 MAX SWING

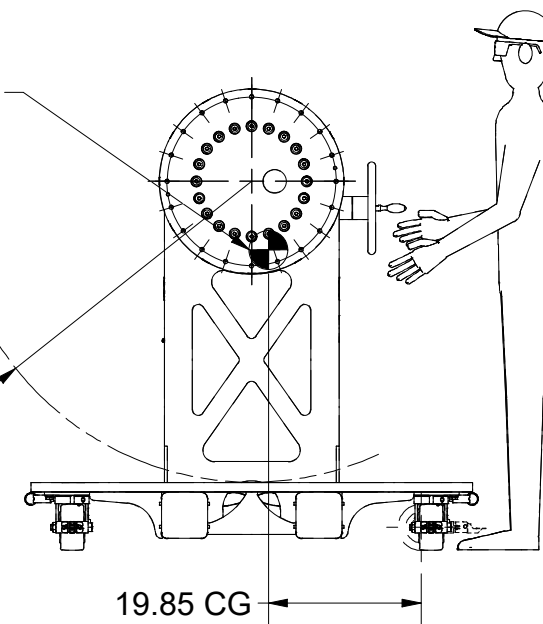

LATERAL STABILITY WITH 2,600 LB PAYLOAD: $19.85 / 36.12 = .55 G$

5. WEIGHT IN TITLE BLOCK INCLUDES 2,600 LB PAYLOAD.
4. GEARBOX SIDE END CAPS CAN BE REMOVED AND FRAME LIFTED FROM GEARBOX END WITH FORKLIFT. FORKS MUST GO MINIMUM 1 FOOT PAST UNLOADED CG (42" INTO TUBE MIN.) AND AT LEAST 58" INTO TUBE FOR LOADED FIXTURE.
3. BASIC CONFIGURATION SHOWN ON SHEET 1: CTL-48-P24-C6. FOR ADDITIONAL CONFIGURATION OPTIONS, SEE SHEET 2 FOR KIT PART NUMBERS.
2. FINISHES/LUBRICANTS:
 - A. "STANDARD" FLOTRON FINISHES (SHOWN) - CLASS 10K (ISO 7 CLEAN ROOM COMPATIBLE FINISHES) - FLOTRON BLUE POWDER COATED FRAMES; GEARBOX SPRAY PAINTED FLOTRON BLUE (CARDINAL 6441-9631); NICKEL PLATED COMPONENTS (NO ZINC); STAINLESS STEEL OR BLACK OXIDE FASTENERS AND MISC. HARDWARE; CASTERS LUBRICATED WITH STA-LUBE SL3131 HEAVY DUTY DRUM BRAKE GREASE; (KRYTOX GPL207 FOR FASTNERS THAT ARE NOT ON A TORQUE CHART); MOBILTAC 375NC (OR EQUIVALENT) TO ALL SLEWING RING TEETH; SLEWING RING INNER RACEWAY COMES PRE-LUBRIATED WITH MOBILUX EP2 (OR EQUIVALENT) AND NO ADDITIONAL LUBRICATION IS REQUIRED.
 - B. "C" FINISH - CLASS 1K (ISO 6 CLEAN ROOM COMPATIBLE FINISHES) - SKY WHITE POWDER COATED FRAMES; GEARBOX SPRAY PAINTED GLOSS WHITE EPOXY (DUPONT PFW-510-S9); NICKEL PLATED COMPONENTS (NO ZINC); STAINLESS STEEL OR BLACK OXIDE FASTENERS AND MISC. HARDWARE; CASTERS LUBRICATED WITH KRYTOX GPL 207; (KRYTOX GPL207 FOR FASTNERS THAT ARE NOT ON A TORQUE CHART); MOBILTAC 375NC (OR EQUIVALENT) TO ALL SLEWING RING TEETH; SLEWING RING INNER RACEWAY COMES PRE-LUBRIATED WITH MOBILUX EP2 (OR EQUIVALENT) AND NO ADDITIONAL LUBRICATION IS REQUIRED.
1. LOAD RATING FOR PRIMARY AXIS (NO SA OPTION): 2,600 LBS @ 30" WITH 3.0" MAX ECCENTRICITY CONSIDERING A SIMULTANEOUS 1/2g SIDE LOAD (WORST CASE DIRECTION) AND A 1G VERTICAL LOAD. $SF_y=3$ & $SF_{ult}=5$.
 MAX TORQUE ON 60:1 RATIO (STANDARD) GEARBOX: 8,000 IN-LBS (7,000 IN-LBS MAX EASY CRANK)
 MAX TORQUE ON 300:1 RATIO (DR3) GEARBOX: 8,000 IN-LBS (8,000 IN-LBS MAX EASY CRANK)

NOTES:

PROPRIETARY
 This Drawing is the property of FLOTRON, Inc. and is not to be used, copied or reproduced in any way other than for the particular purpose for which it is provided, and when said purpose has been fulfilled, it should be destroyed or returned to FLOTRON, Inc.

UNLESS OTHERWISE SPECIFIED DIMENSIONS ARE IN INCHES
 LINEAR TOLERANCES: ±.03 .XX
 ANGULAR TOLERANCES: ±.5° .XXX
 DO NOT SCALE DRAWING
 INTERPRET DIMENSIONING AND TOLERANCING PER ASME Y15.5-2018
 INTERPRET DWG. PER ASME Y14.100

FLOTRON® 2630 PROGRESS STREET
 VISTA, CALIFORNIA 92081
<http://www.flotron.com>

CANTILEVERED HOLDING FIXTURE (CTL), 48 IN HEIGHT

SCALE	SIZE	DRAWING NO.
1 : 25	B	8024-500PROP
WT: 3915.6 lbmass		Cad software: Inventor
SHEET		1 OF 9



Small Satellite Fixture
Creating a model number

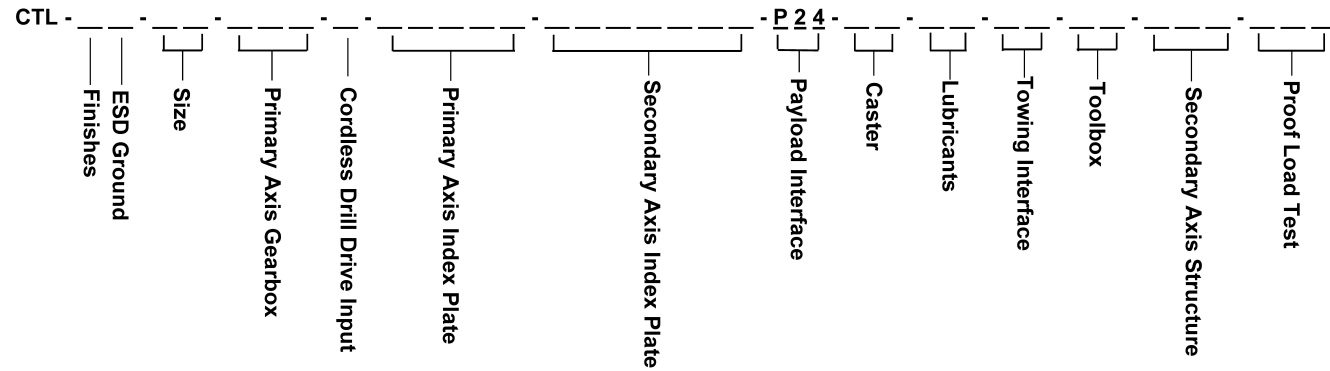

CTL CREATING A MODEL NUMBER

Finishes

(blank) - Standard finishes (no zinc)
C - - - - Clean room finishes

ESD Ground

(blank) - No ESD ground
E - - - - Ground lug and drag chain for use in EPA's

Size

36 - - - 36" Primary axis centerline to floor height
48 - - - 48" Primary axis centerline to floor height
60 - - - 60" Primary axis centerline to floor height
AH - - -30" to 60" Adjustable centerline to floor height

Primary Axis Gearbox

(blank) - Standard 60:1 ratio gearbox
DR3 - - - 300:1 ratio gearbox (Must select "D" option)

Cordless Drill Drive Input

(blank) - No drill drive (hand crank only)
D - - - - Battery powered right angle drill permanently mounted to gearbox input shaft.
(Must select DR3 gearbox option)

Primary Axis Index plate

(blank) - No index plate on primary axis
IND30 - 30° Index plate on primary input
(Must select AH option)

Secondary Axis Index plate

(blank) - No index plate on secondary axis
SAIND30 Secondary axis of rotation index plate
(Must select SA option)

Payload Interface

P24 - - - Standard Ø24" circular interface plate
20X through holes for ½" fasteners on Ø22" bolt circle

Proof Load Test

(blank) - - No proof load test
PLT - - - - Standard proof load test (includes deliverable report)

Secondary Axis of Rotation Structure

(blank) - No secondary axis of rotation
SA1 - - - - Secondary axis of rotation (Bolt Position 1)
SA2 - - - - Secondary axis of rotation (Bolt Position 2)
SA3 - - - - Secondary axis of rotation (Bolt Position 3)
SA4 - - - - Secondary axis of rotation (Bolt Position 4)
SA5 - - - - Secondary axis of rotation (Bolt Position 5)
SA6 - - - - Secondary axis of rotation (Bolt Position 6)

*NOTE: See proposal drawing to determine correct bolt position.
Bolt positions can be changed in the field, but bolt position selected will be the bolt position fixture is shipped with. SA1-SA4 not available with CTL-36 size.*

Toolbox

(blank) - No storage toolbox
BX - - - Storage toolbox included

Towing Interface

(blank) - No tow bar
T1 - - - - Tow bar included

Lubricants:

(blank) - Standard lubricant
L1 - - - - Caster swivel bearings lubricated with Krytox GPL 207
L2 - - - - Caster swivel bearings lubricated with Braycote 601EF
NOTE: "C" finish includes L1 lubricants

Caster

C6 - - - Ø6" x 3" Heavy duty nylon wheel caster with brakes and swivel locks
C8 - - - Ø8" x 2 ½" Heavy duty nylon wheel caster with brakes and swivel locks

This Drawing is the property of FLOTRON, Inc. and is not to be used, copied or reproduced in any way other than for the particular purpose for which it is provided, and when said purpose has been fulfilled, it should be destroyed or returned to FLOTRON, Inc.



2630 PROGRESS STREET
VISTA, CALIFORNIA 92081
<http://www.flotron.com>

SCALE	VARIES	SIZE	B	DRAWING NO.	8024-500PROP
					SHEET 2 OF 9

ESD **E** GROUNDING OPTION

ESD KIT INCLUDES TESTS FOR CONTINUITY

DRAG CHAIN ON BOTTOM OF DRIVE SIDE LEG CAN BE SNAPPED INTO STOWED POSITION DURING TRANSPORTATION IF DESIRED.

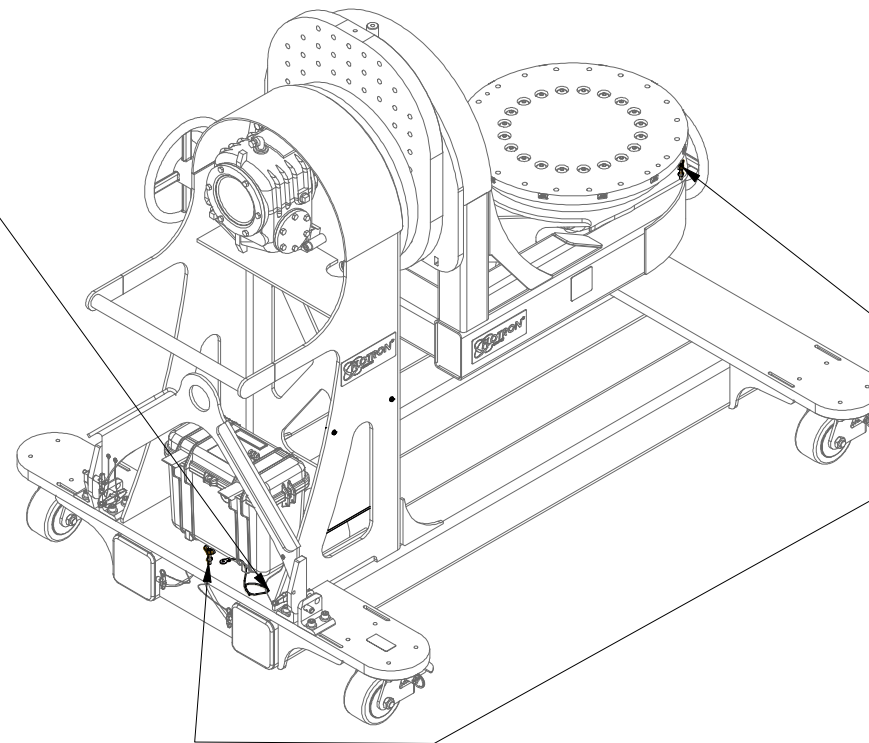

5/16-24 BRASS GROUNDING LUGS ON SECONDARY AXIS CRADLE AND BASE FRAME

STANDARD GEARBOX OPTION (60:1)

NON-BACKDRIVING 60:1 RATIO SINGLE STAGE DOUBLE ENVELOPING WORM GEAR DRIVE.

STANDARD GEARBOX TORQUE CAPACITY: 8,000 IN-LBS
STANDARD GEARBOX MAX EASY CRANK TORQUE: 7,000 IN-LBS
 (EASY CRANK IS DEFINED AS A 12 LB INPUT FORCE ON THE CRANK HANDLE)

216 TURNS ON INPUT HANDWHEEL FOR 1 ROTATION OF INTERFACE

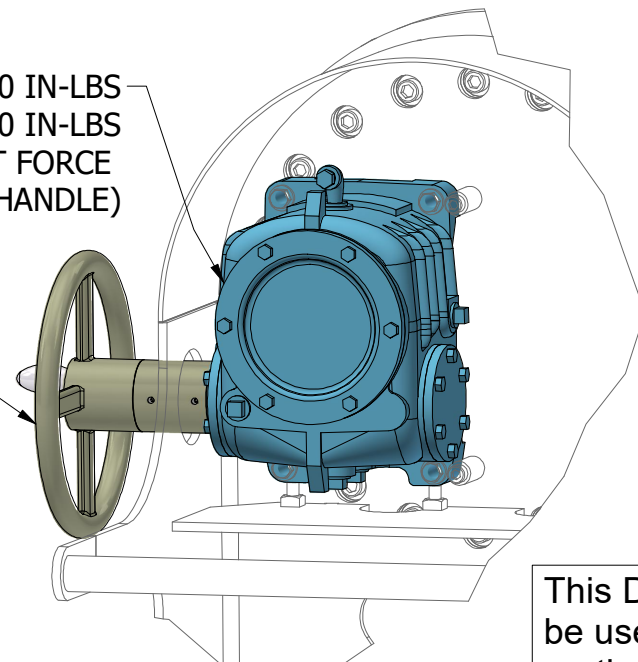
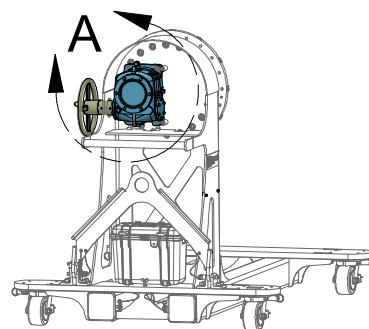

DETAIL A
SCALE 1 : 8

DR3 GEARBOX OPTION (300:1) WITH DRILL DRIVE **D** OPTION

NON-BACKDRIVING 300:1 RATIO TWO STAGE DOUBLE ENVELOPING WORM GEAR DRIVE.

DR3 GEARBOX TORQUE CAPACITY: 8,000 IN-LBS
 DRILL MAX RPM IS 1,200 RESULTING IN A MAX OUTPUT PAYLOAD ROTATION OF 1.1 RPM.
 WITH **D** OPTION, FULL GEARBOX TORQUE CAPACITY CAN BE USED.
 COMES STANDARD WITH CLUTCH BETWEEN THE GEARBOX AND HAND CRANK TO PREVENT OVER-TORQUE OF GEARBOX IN CASE INDEX PIN WAS NOT REMOVED BEFORE ROTATION OR PAYLOAD ECCENTRICITY IS TOO HIGH.

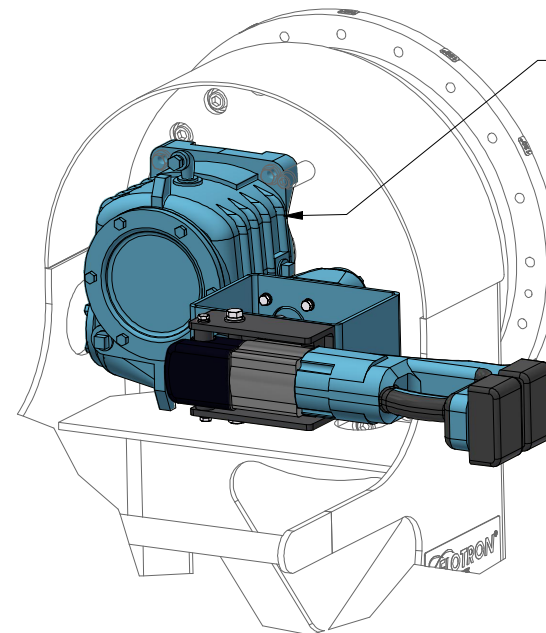

DETAIL B
SCALE 1 : 10

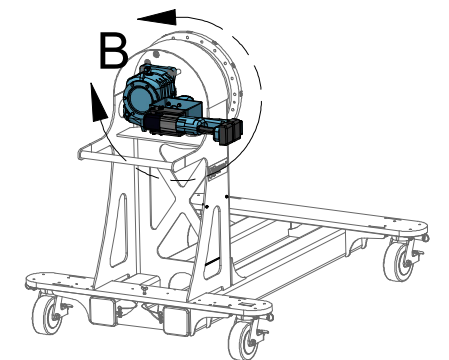

This Drawing is the property of FLOTRON, Inc. and is not to be used, copied or reproduced in any way other than for the particular purpose for which it is provided, and when said purpose has been fulfilled, it should be destroyed or returned to FLOTRON, Inc.



2630 PROGRESS STREET
 VISTA, CALIFORNIA 92081
<http://www.flotron.com>

SCALE	VARIES	SIZE	B	DRAWING NO.	8024-500PROP
					SHEET 3 OF 9

P24 INTERFACE PLATE DETAIL

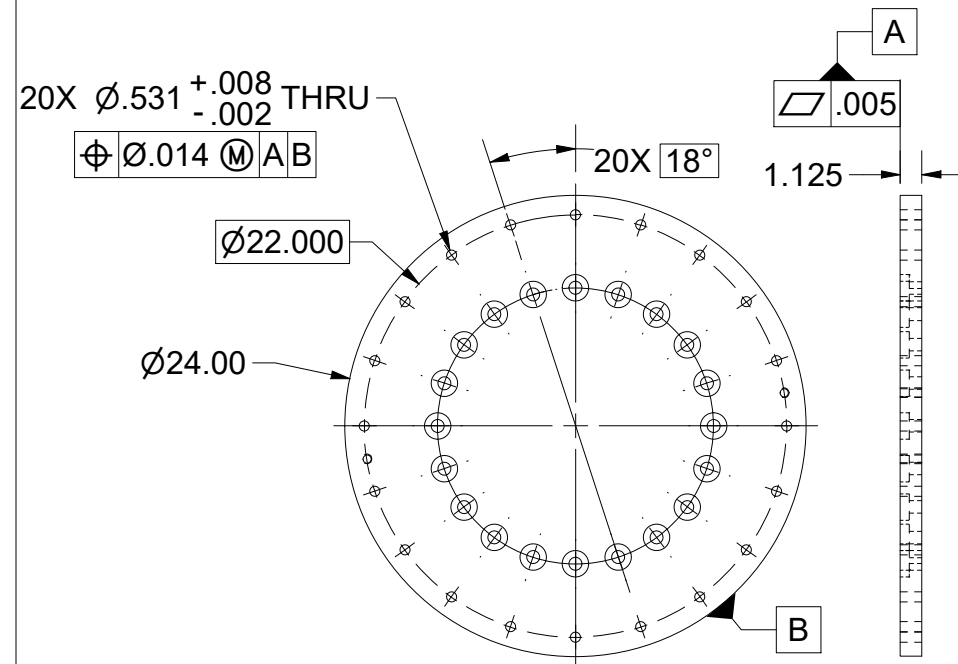

BX TOOLBOX

STORAGE BOX FOR TOOLS, SMALL PARTS, AND MISC. HARDWARE

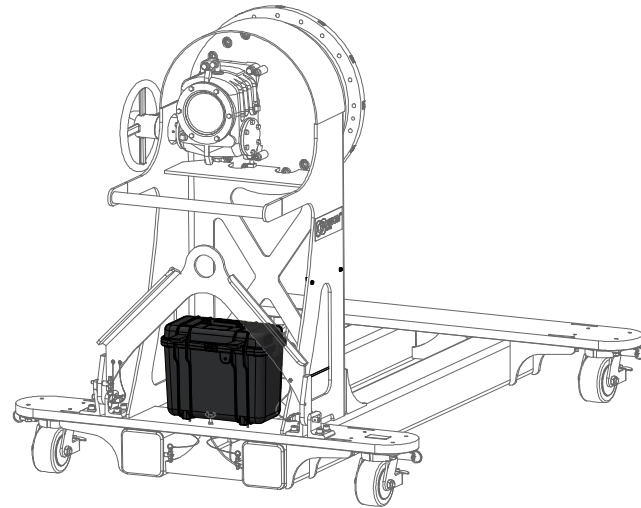

T3 REMOVEABLE TOW BAR

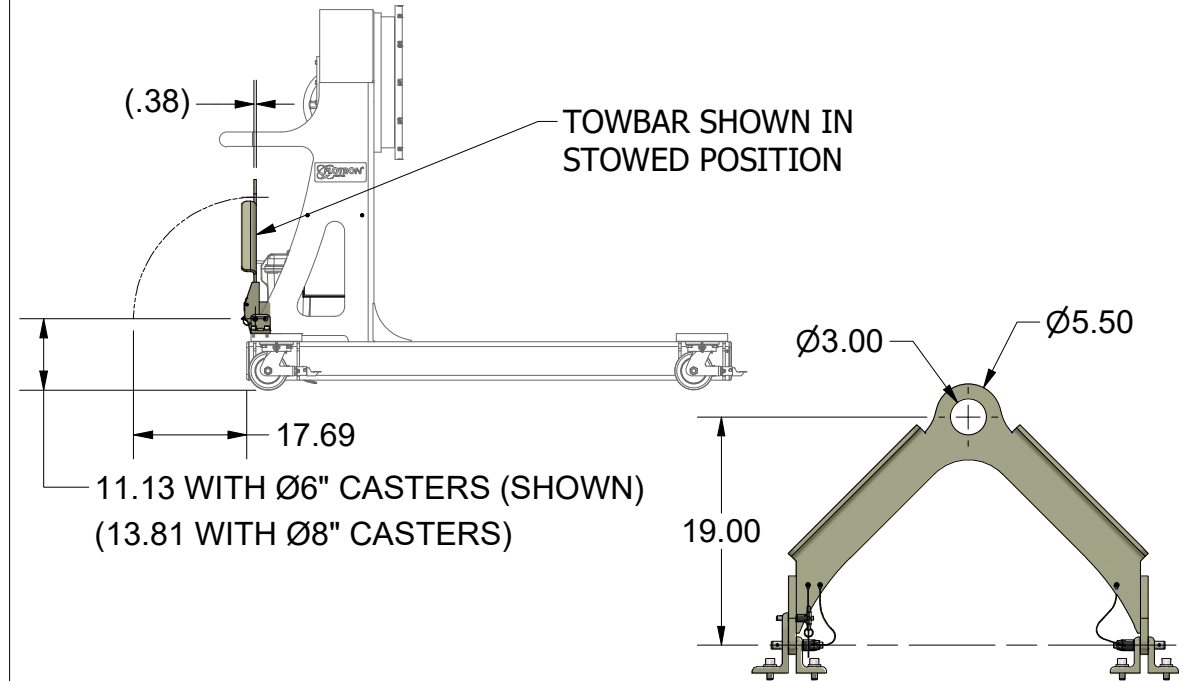

CASTER OPTIONS

$\varnothing 6''$ C6 CASTERS

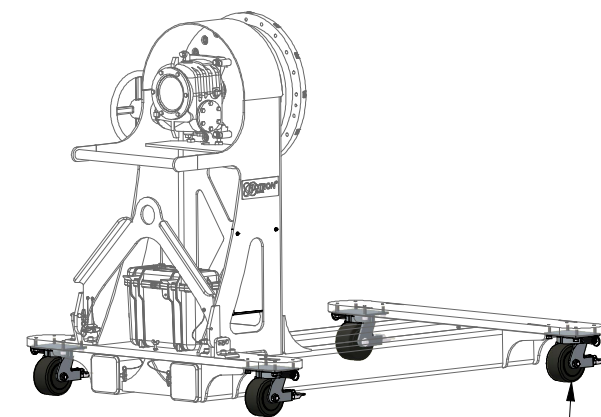
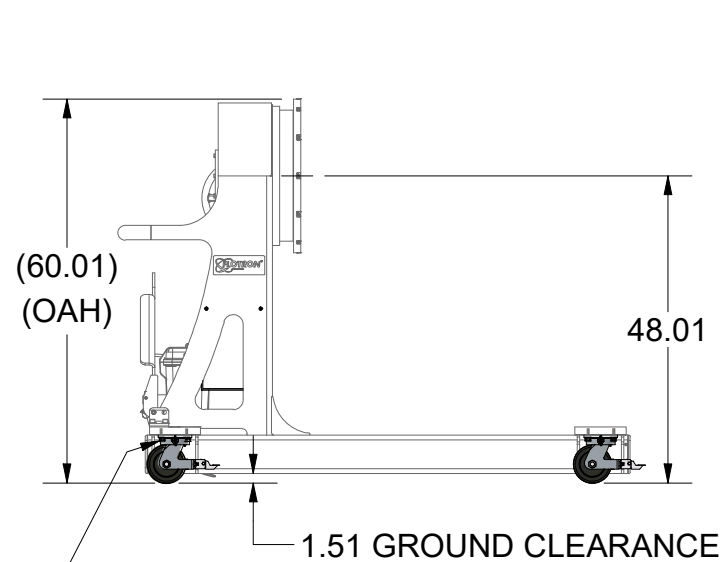

QTY. 4 $\varnothing 6''$ X 3" WIDE
 NYLON CASTERS WITH BRAKES
 & 4 POSITION SWIVEL LOCKS

$\varnothing 8''$ C8 CASTERS

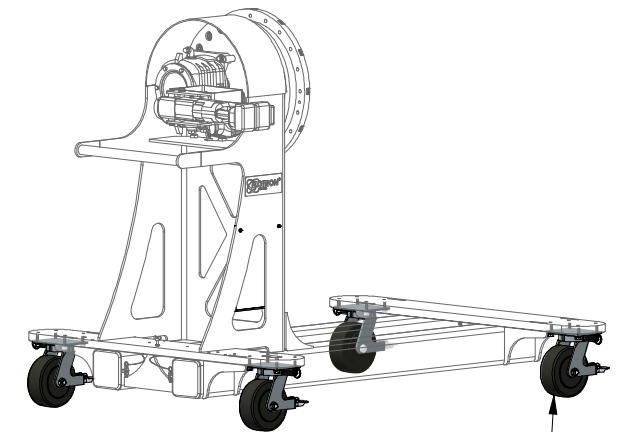
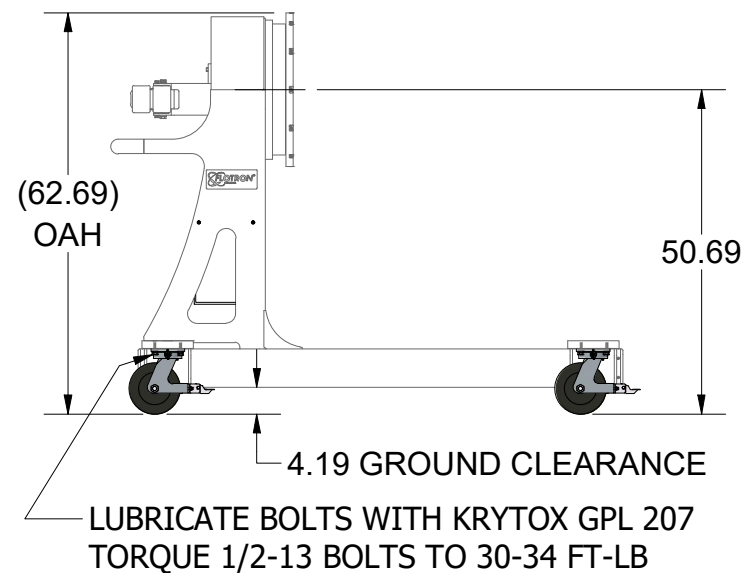

QTY. 4 $\varnothing 8''$ X 3" WIDE
 NYLON CASTERS WITH BRAKES
 & 4 POSITION SWIVEL LOCKS

LUBRICATE BOLTS WITH KRYTOX GPL 207
 TORQUE 1/2-13 BOLTS TO 30-34 FT-LB

LUBRICATE BOLTS WITH KRYTOX GPL 207
 TORQUE 1/2-13 BOLTS TO 30-34 FT-LB

This Drawing is the property of FLOTRON, Inc. and is not to be used, copied or reproduced in any way other than for the particular purpose for which it is provided, and when said purpose has been fulfilled, it should be destroyed or returned to FLOTRON, Inc.



2630 PROGRESS STREET
 VISTA, CALIFORNIA 92081
<http://www.flotron.com>

SCALE	VARIES	SIZE	B	DRAWING NO.	8024-500PROP
					SHEET 4 OF 9

SAIND30 SECONDARY AXIS INDEX PLATE DETAIL

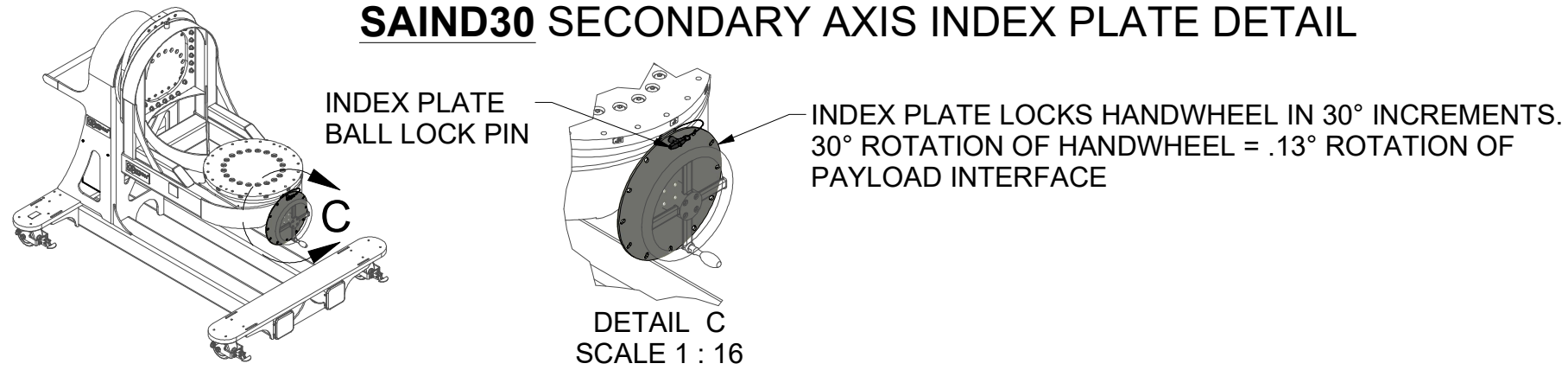

SA1- SA6 SECONDARY AXIS ROTATION FRAME

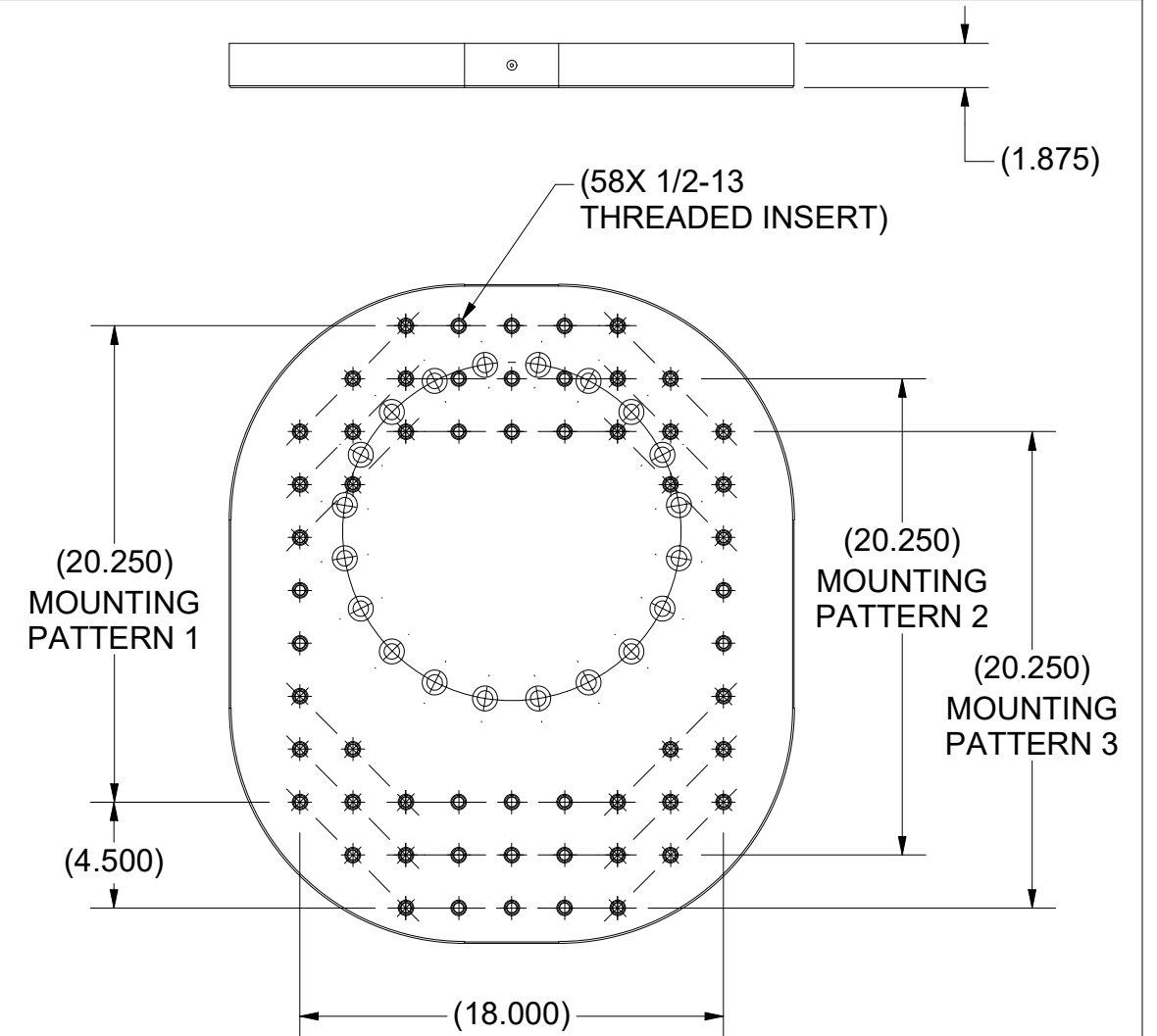
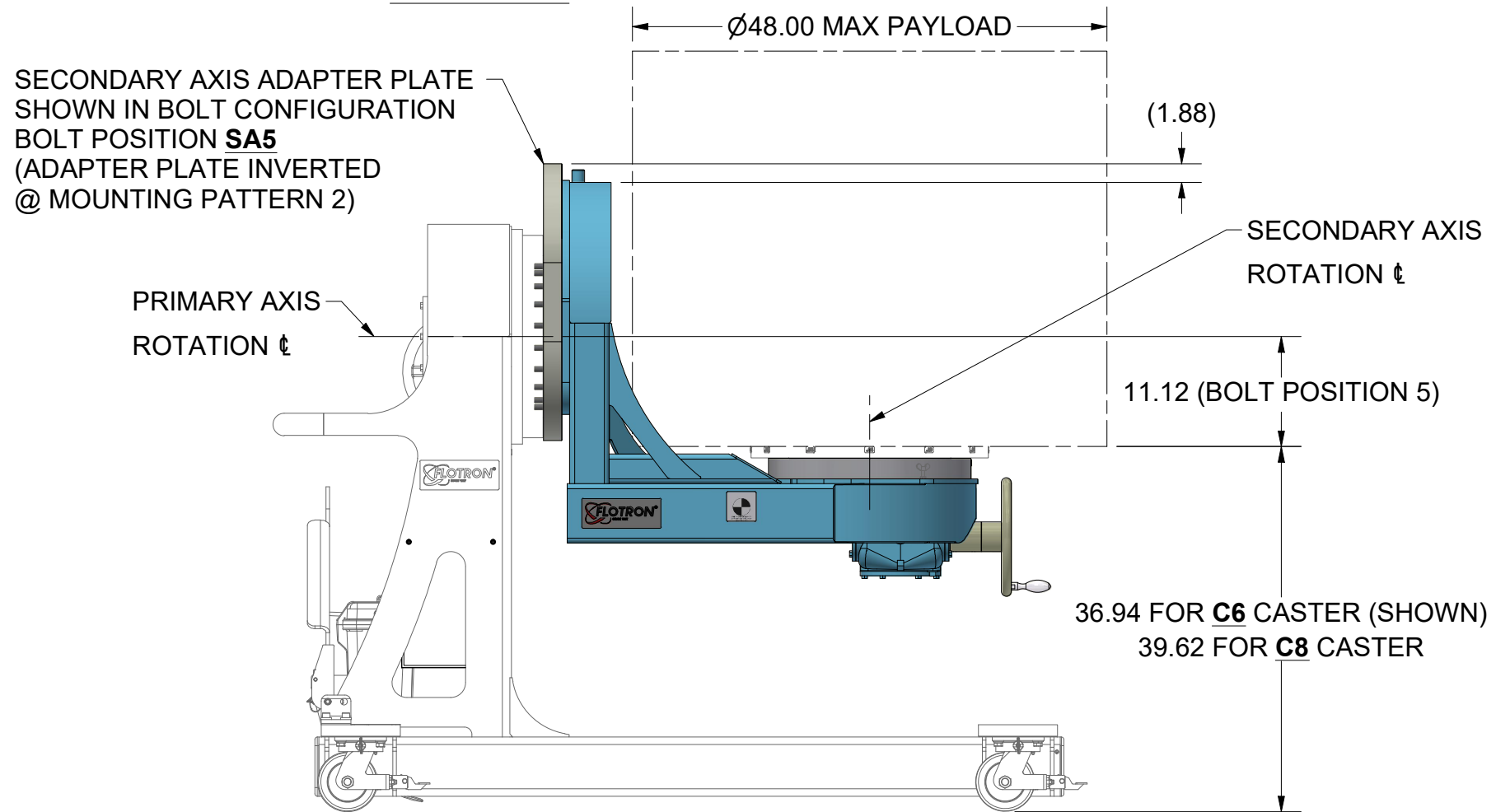

ADAPTER PLATE SHOWN IN "UPRIGHT" ORIENTATION IN VIEW ABOVE

Adapter Plate Installation Guide		
Configuration Bolt Position	Adapter Plate Mounting Pattern	Adapter Plate Orientation
SA1	3	UPRIGHT
SA2	2	UPRIGHT
SA3	1	UPRIGHT
SA4	1	INVERTED
SA5	2	INVERTED
SA6	3	INVERTED

5. SEE SHEETS 7-9 FOR LOAD CURVES AND DIMENSIONAL DATA OF ALL BOLT POSITIONS (SA1-SA6)
4. CONFIGURATION SHOWN ON THIS SHEET: CTL-E-48-P24-C6-T1-BX-SA5.
3. WHEN SECONDARY AXIS OF ROTATION FRAME IS EMPTY IT MUST BE IN POSITION VERTICAL ORIENTATION AS SHOWN.
2. LOAD RATING WHEN USING SECONDARY AXIS OF ROTATION: 1,600 LBS WITH A 5.0" MAX ECCENTRICITY FROM PRIMARY AND SECONDARY AXIS. ASSEMBLED AS SHOWN ON THIS SHEET CONSIDERING A SIMULTANEOUS 1/2G SIDE LOAD (WORST CASE DIRECTION) AND A 1G VERTICAL LOAD. SFy=3 & SFult=5. MAX TORQUE ON PRIMARY AND SECONDARY AXIS GEARBOX 8,000 IN-LBS (7,000 IN-LBS MAX EASY CRANK FOR SECONDARY AXIS GEARBOX)
1. CONFIGURATION ON THIS SHEET HAS A UNIT WEIGHT OF 2,080 LBS INCLUDES BASE AND 765 LB SECONDARY AXIS (WITH INTERFACE)

NOTES:

This Drawing is the property of FLOTRON, Inc. and is not to be used, copied or reproduced in any way other than for the particular purpose for which it is provided, and when said purpose has been fulfilled, it should be destroyed or returned to FLOTRON, Inc.



2630 PROGRESS STREET
VISTA, CALIFORNIA 92081
<http://www.flotron.com>

SCALE	VARIES	SIZE	B	DRAWING NO.	8024-500PROP
					SHEET 5 OF 9

CTL-48 With Secondary Axis or Rotation Dynamic Loading For Cradle **Bolt**
Position 1

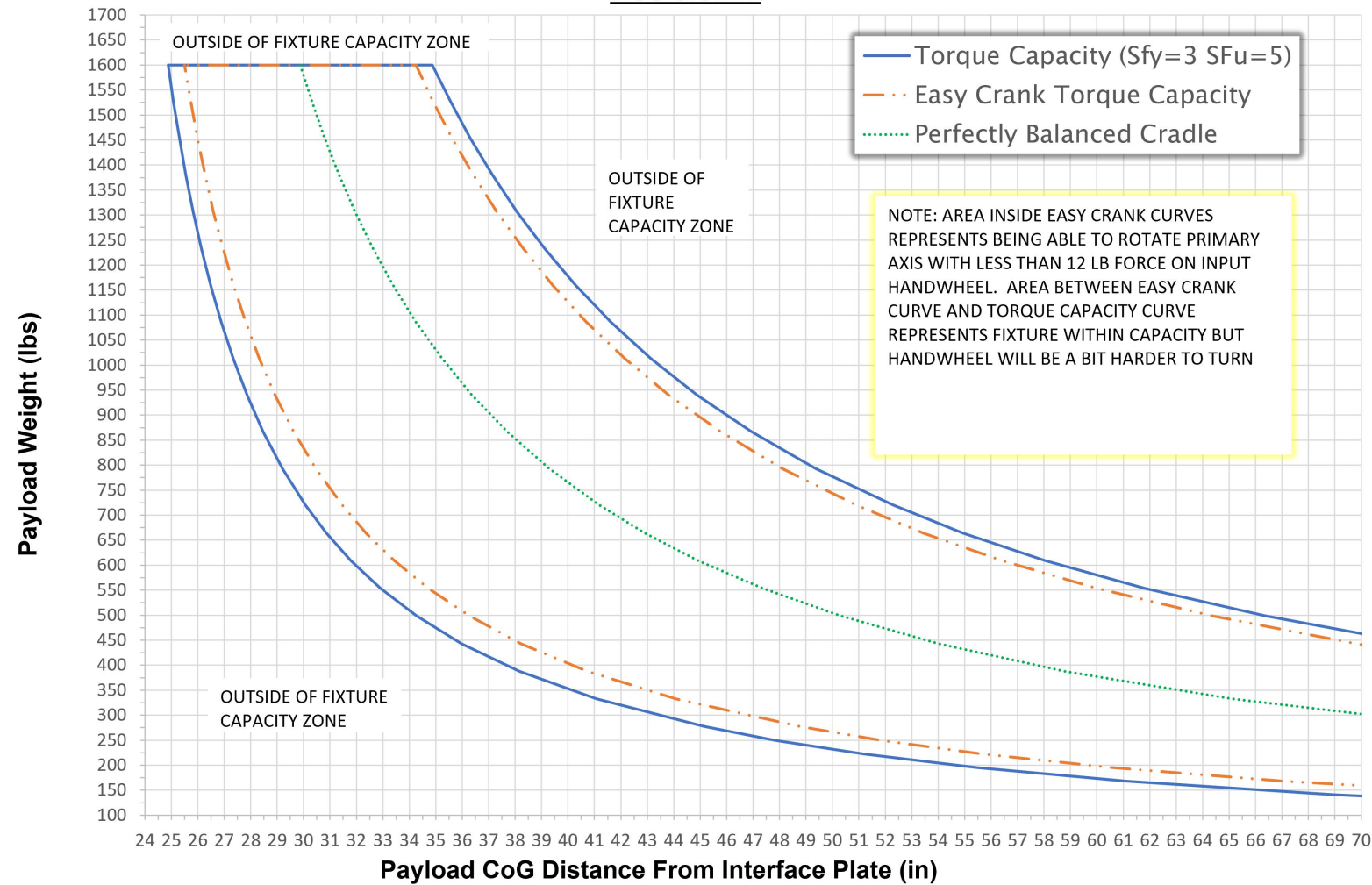

CTL-48 With Secondary Axis or Rotation Dynamic Loading For Cradle **Bolt Position 2**

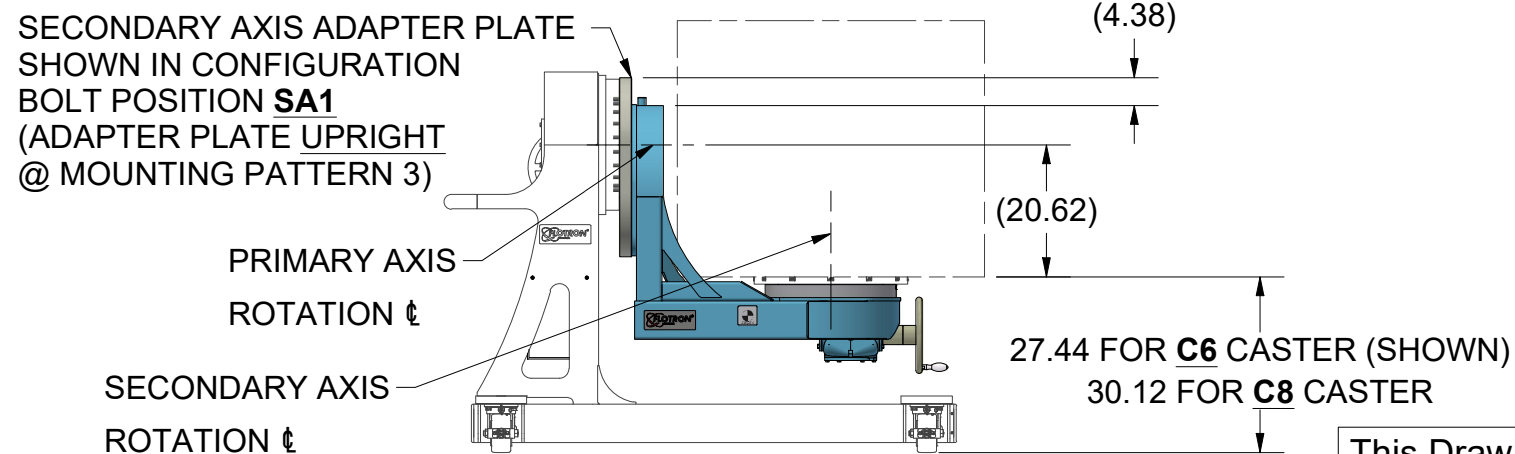
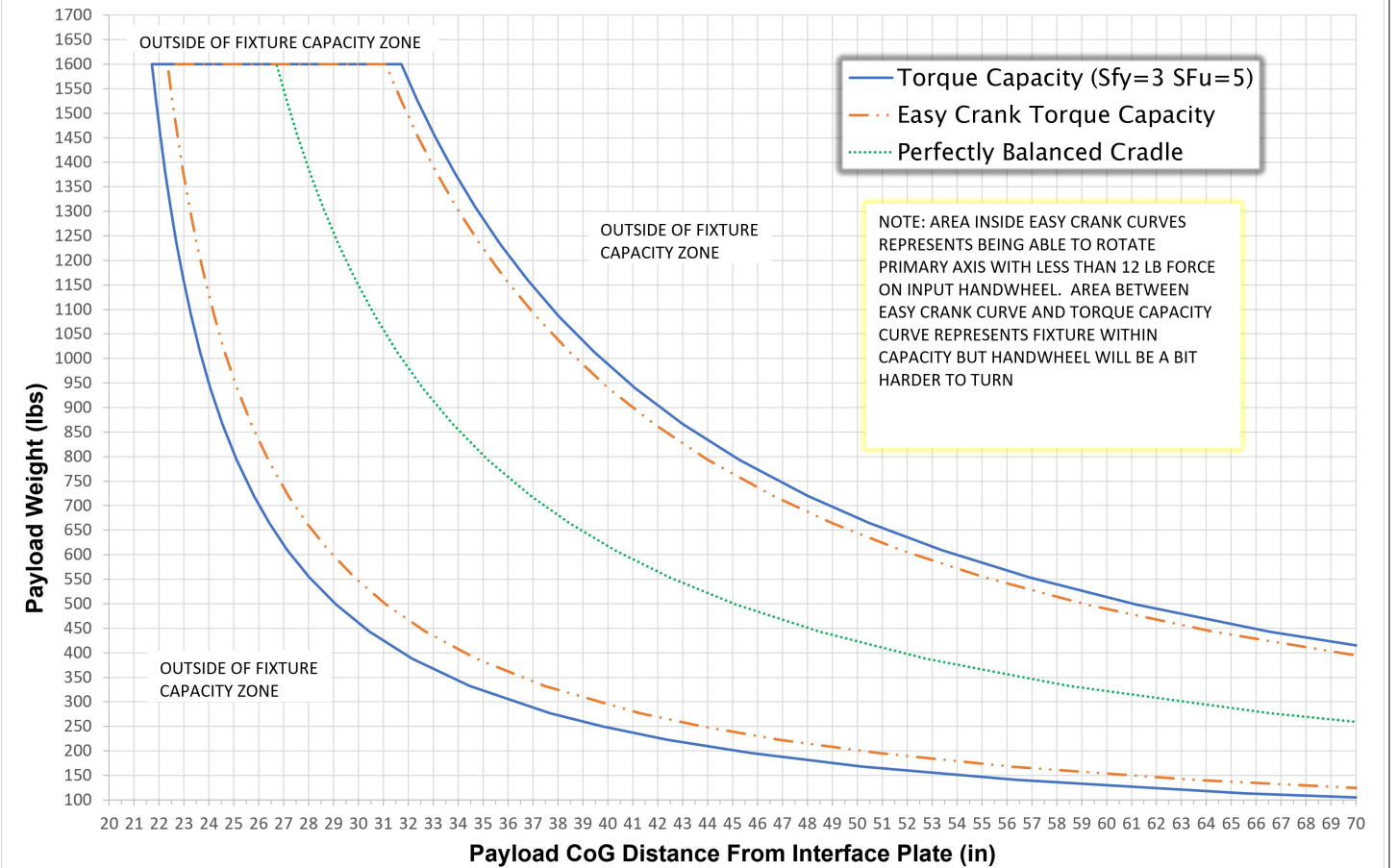

SA1 SECONDARY AXIS OF ROTATION STRUCTURE

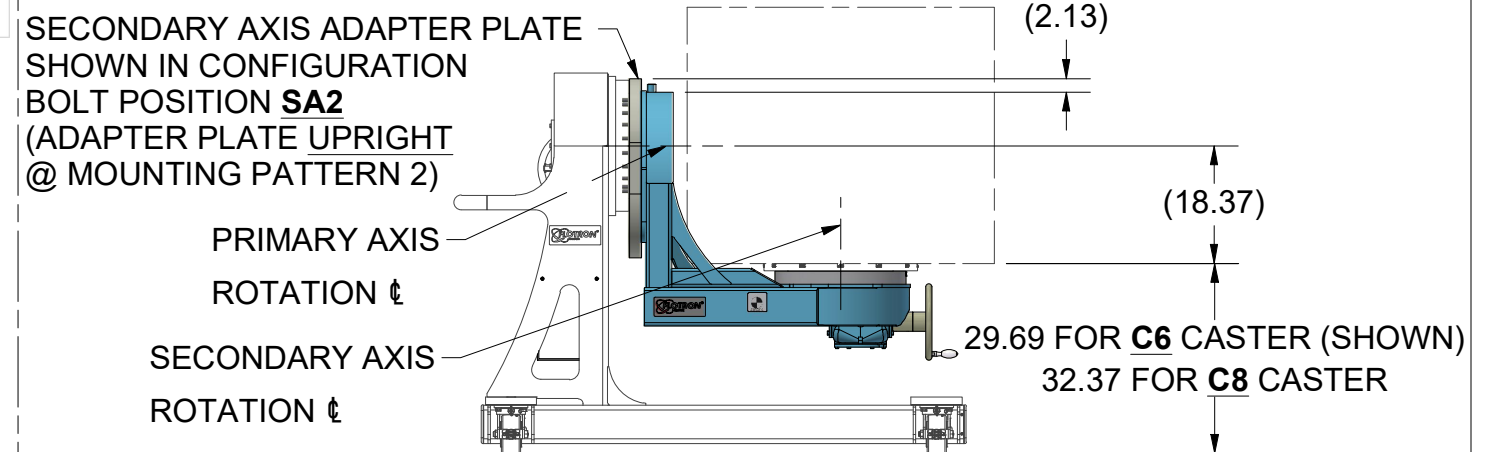

SA2 SECONDARY AXIS OF ROTATION STRUCTURE

This Drawing is the property of FLOTRON, Inc. and is not to be used, copied or reproduced in any way other than for the particular purpose for which it is provided, and when said purpose has been fulfilled, it should be destroyed or returned to FLOTRON, Inc.



2630 PROGRESS STREET
VISTA, CALIFORNIA 92081
<http://www.flotron.com>

SCALE	VARIES	SIZE	B	DRAWING NO.	8024-500PROP
					SHEET 6 OF 9

CTL-48 With Secondary Axis or Rotation Dynamic Loading For Cradle **Bolt Position 3**

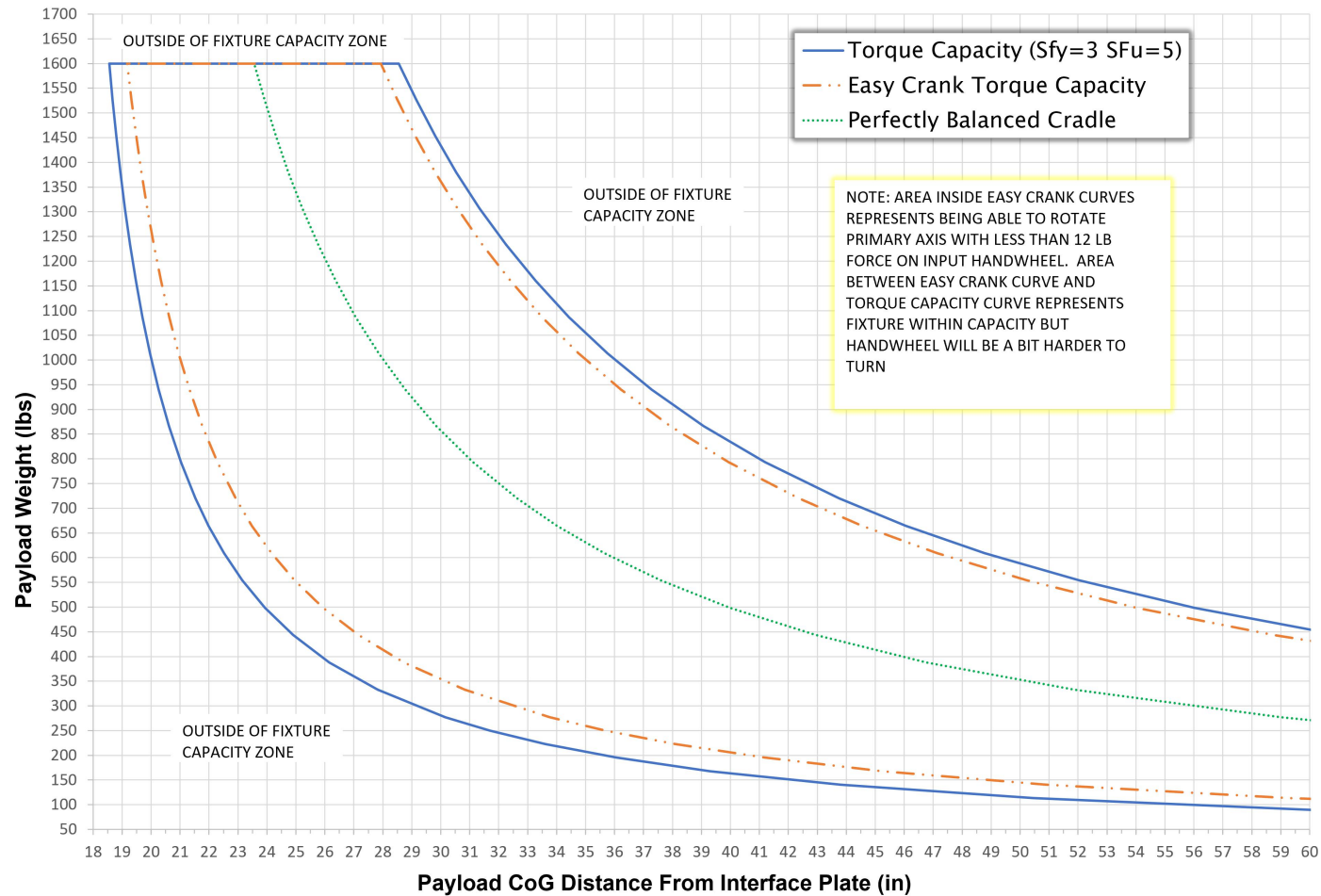

CTL-48 With Secondary Axis or Rotation Dynamic Loading For Cradle **Bolt Position 4**

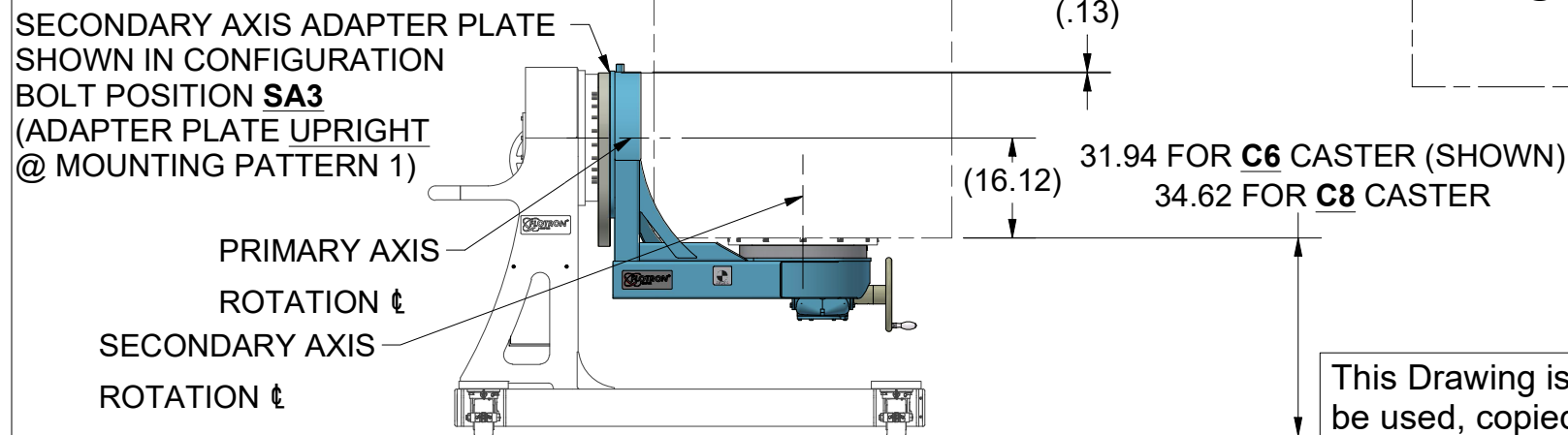
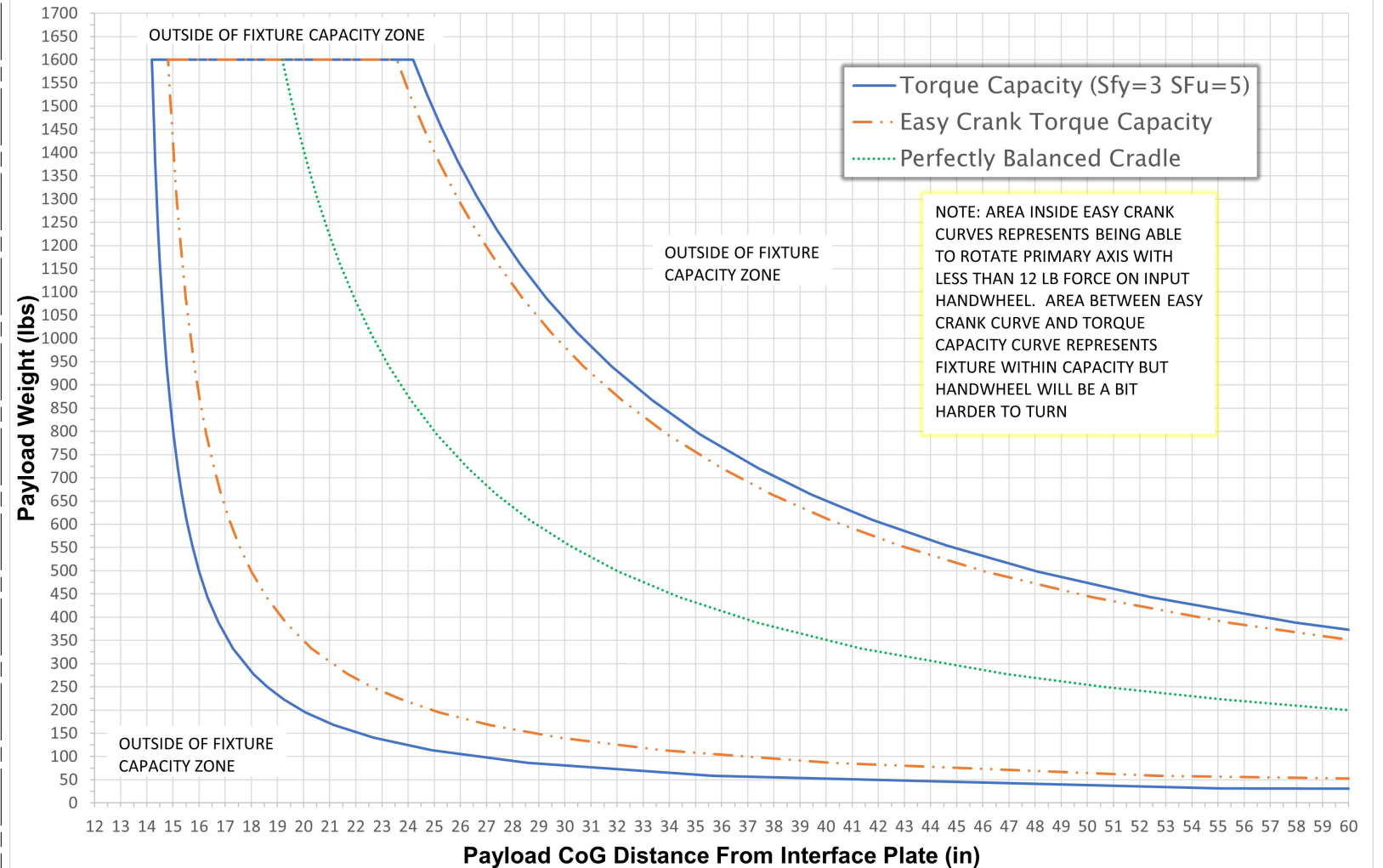

SA3 SECONDARY AXIS OF ROTATION STRUCTURE

SECONDARY AXIS ADAPTER PLATE SHOWN IN CONFIGURATION BOLT POSITION **SA4** (ADAPTER PLATE INVERTED @ MOUNTING PATTERN 1)

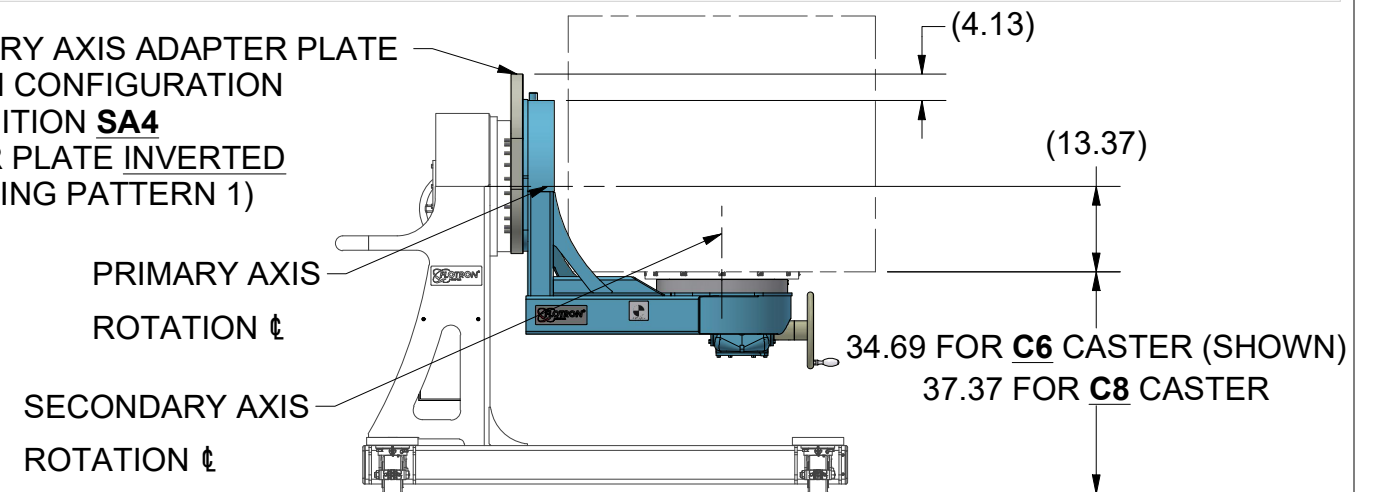

SA4 SECONDARY AXIS OF ROTATION STRUCTURE

This Drawing is the property of FLOTRON, Inc. and is not to be used, copied or reproduced in any way other than for the particular purpose for which it is provided, and when said purpose has been fulfilled, it should be destroyed or returned to FLOTRON, Inc.



2630 PROGRESS STREET
VISTA, CALIFORNIA 92081
<http://www.flotron.com>

SCALE	VARIES	SIZE	B	DRAWING NO.	8024-500PROP
					SHEET 7 OF 9

CTL-48 With Secondary Axis or Rotation Dynamic Loading For Cradle **Bolt Position 5**

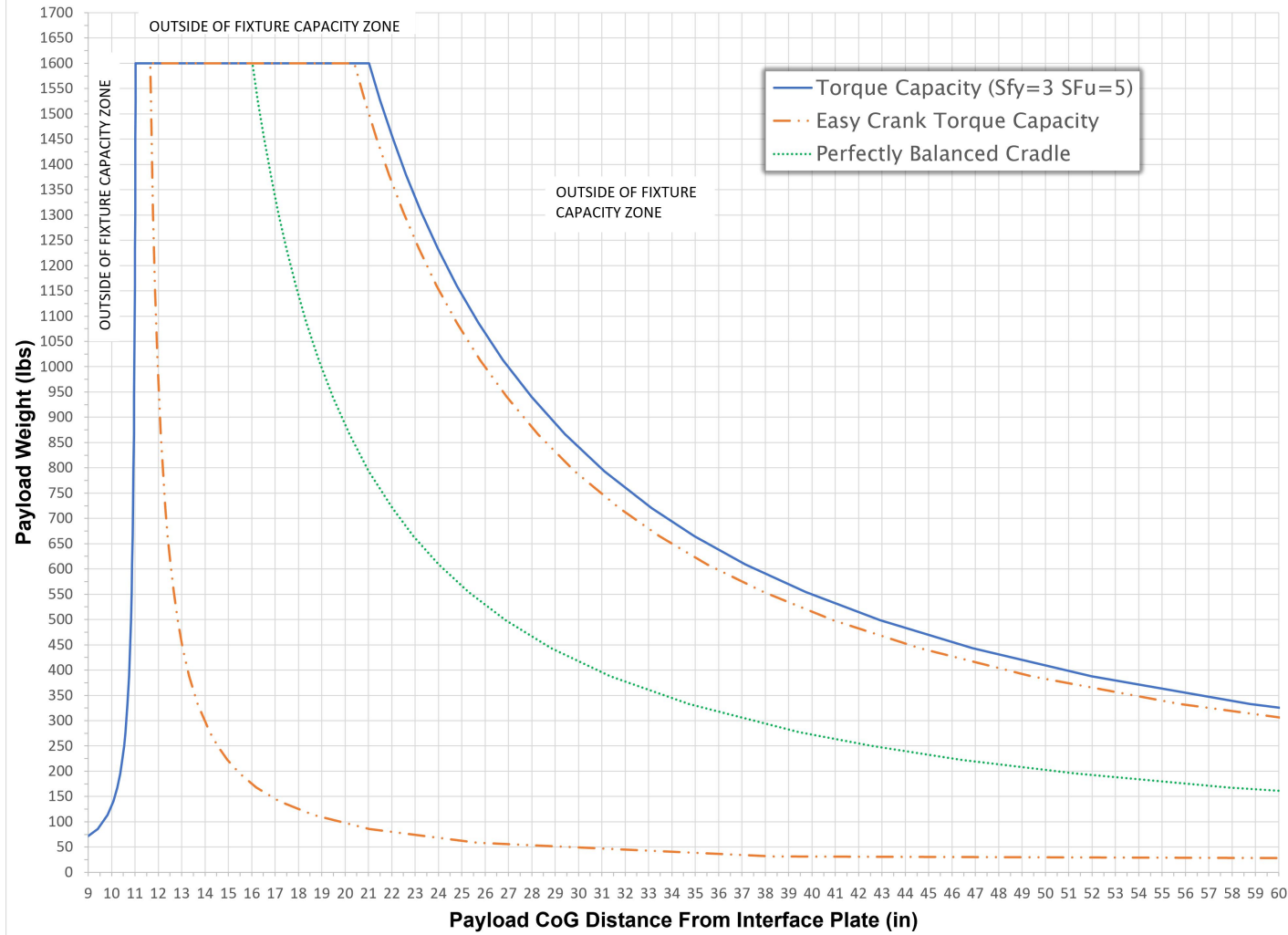

CTL-48 With Secondary Axis or Rotation Dynamic Loading For Cradle **Bolt Position 6**

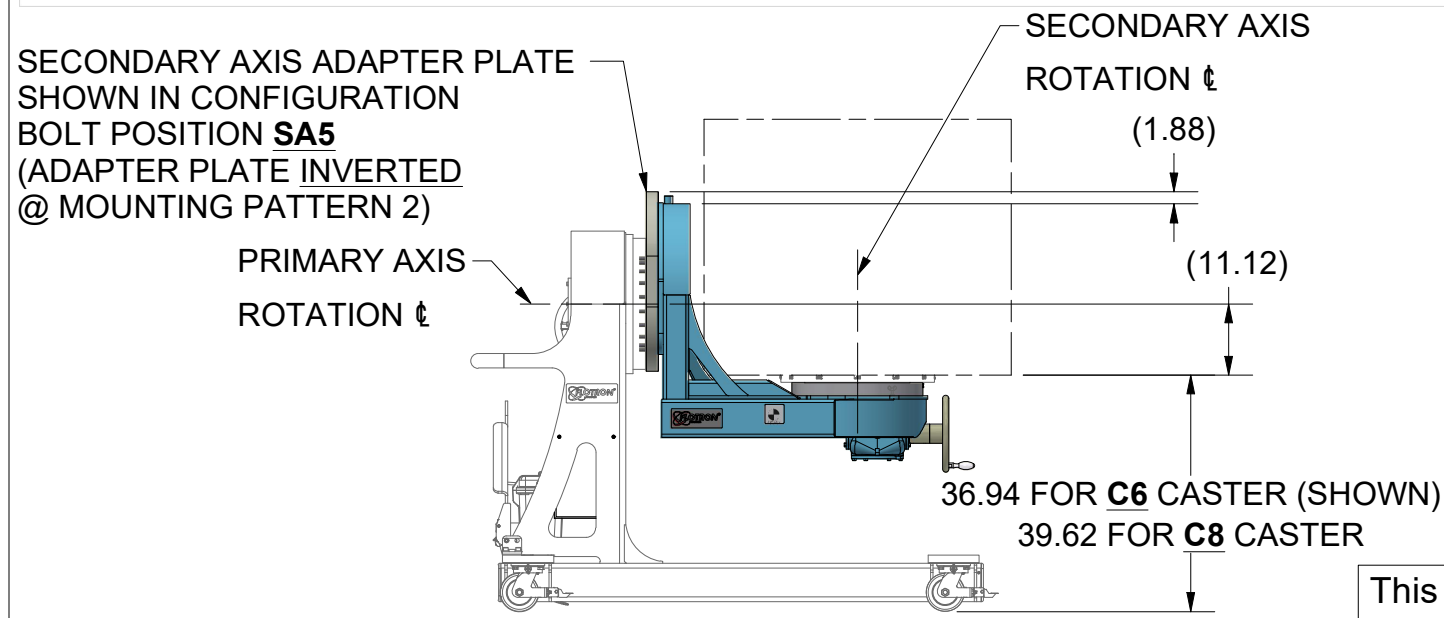
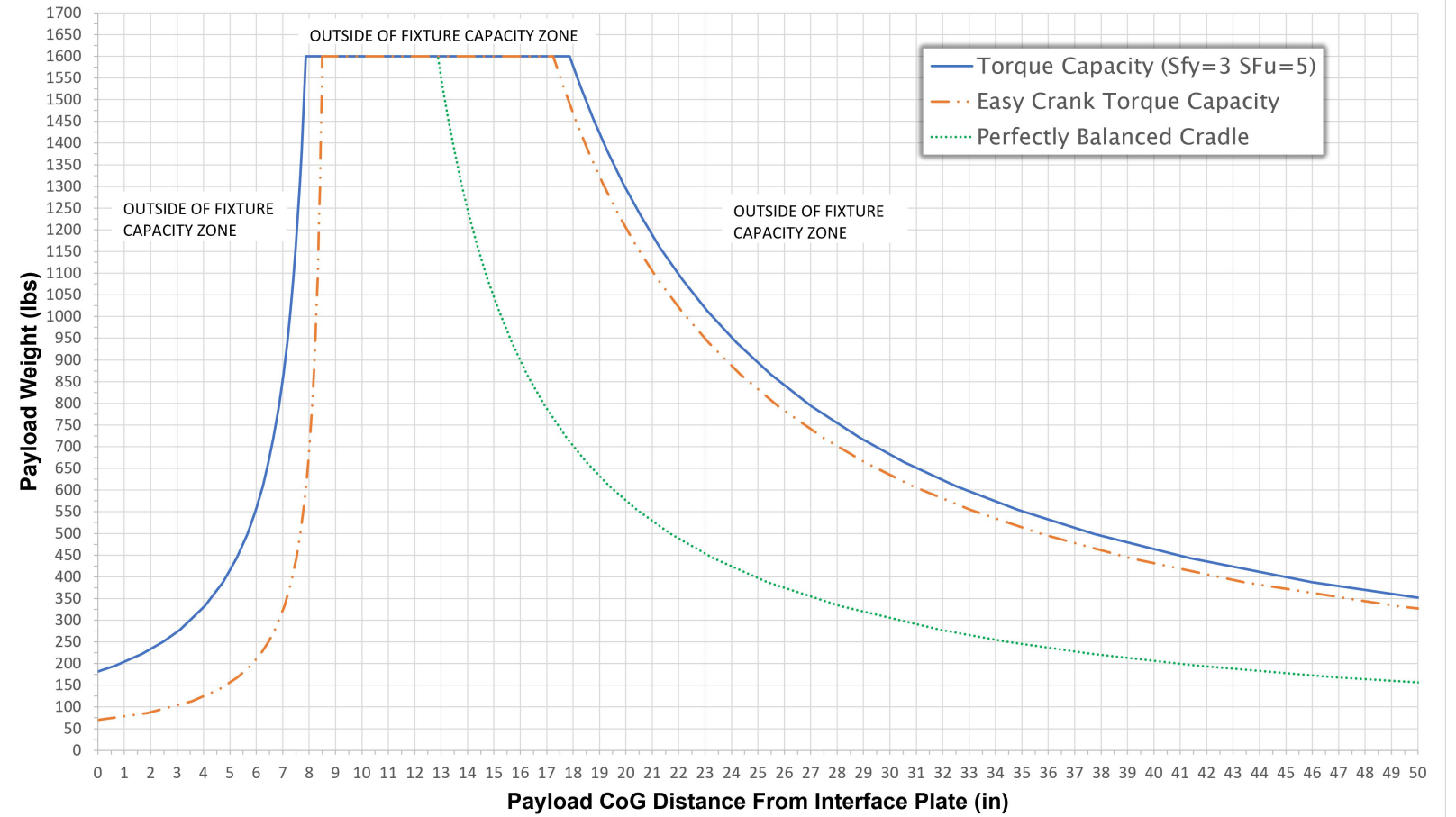

SA5 SECONDARY AXIS OF ROTATION STRUCTURE

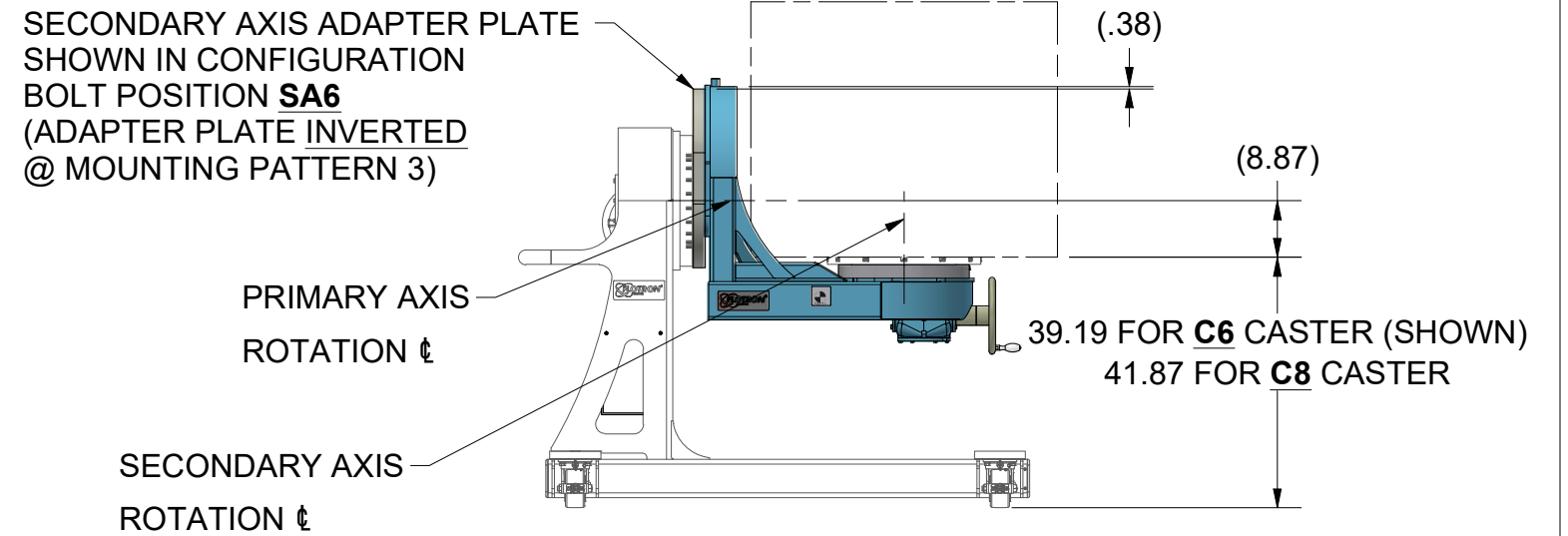

SA6 SECONDARY AXIS OF ROTATION STRUCTURE

This Drawing is the property of FLOTRON, Inc. and is not to be used, copied or reproduced in any way other than for the particular purpose for which it is provided, and when said purpose has been fulfilled, it should be destroyed or returned to FLOTRON, Inc.



2630 PROGRESS STREET
VISTA, CALIFORNIA 92081
<http://www.flotron.com>

SCALE	VARIES	SIZE	B	DRAWING NO.	8024-500PROP
					SHEET 8 OF 9

PLT PROOF LOAD TEST WITH SECONDARY AXIS CRADLE (SA OPTION)

FOR REQUIRED PARTS, SEE ASSEMBLY DRAWING **TBD**

PROOF LOAD REQUIREMENTS:

REQUIRED PROOF LOAD: 3,200 LBS REQUIRED (2X LOAD CAPACITY)

TORQUE PROOF LOAD: 8,000 IN-LBS REQUIRED (1X PRIMARY AND SECONDARY AXIS RATED TORQUE)

PROOF LOAD PROCEDURE WITH SA OPTION (SECONDARY AXIS CRADLE)

1. WEIGH PROOF LOAD AND TAKE A PICTURE OF SCALE WITH LOAD VALUE VISIBLE FOR PROOF LOAD REPORT.
2. INSTALL PROOF LOAD ONTO FIXTURE. TORQUE FASTENERS TO VALUE SHOWN.
3. STOP AS REQUIRED TO REVIEW AND INSPECT ANY UNEXPECTED NOISES OR MOVEMENTS.
4. START TIMER, TAKE A PICTURE OF CLOCK ON FIXTURE, AND HOLD FOR (5) FIVE MINUTES. AFTER 5 MINUTES, TAKE A SECOND PICTURE OF CLOCK ON FIXTURE AND VISUALLY INSPECT FOR CRACKS, DEFORMATION, ETC.
5. ROTATE SECONDARY AXIS FULL 360°. ROTATE PRIMARY AXIS CRADLE $\pm 90^\circ$, HOLD AT EITHER END FOR 5 MINUTES. TAKE PHOTO FOR EACH POSITION.

DELIVERABLE REPORT REQUIRED. IT MUST INCLUDE:

- A) A SUMMARY OF THE TEST PROCEDURE
- B) A PICTURE OF THE ACTUAL MEASURED WEIGHT OF PROOF LOAD ON SCALE. WEIGHT MUST BE EQUAL TO OR HIGHER THAN REQUIRED WEIGHT.
- C) PICTURE OF TIMER WITH PROOF LOAD THAT SHOWS 5 MINUTES OR LONGER FOR EACH TEST.
- D) VISUAL INSPECTION RESULTS

PLT PROOF LOAD TEST FOR PRIMARY AXIS (NO SA OPTION)

FOR REQUIRED PARTS, SEE ASSEMBLY DRAWING **TBD**

PROOF LOAD REQUIREMENTS:

REQUIRED PROOF LOAD: 5,200 LBS REQUIRED (2X LOAD CAPACITY)

TORQUE PROOF LOAD: 8,000 IN-LBS REQUIRED (1X PRIMARY AXIS RATED TORQUE)

PROOF LOAD PROCEDURE FOR PRIMARY AXIS (NO SA OPTION)

1. WEIGH PROOF LOAD AND TAKE A PICTURE OF SCALE WITH LOAD VALUE VISIBLE FOR PROOF LOAD REPORT.
2. INSTALL PROOF LOAD ONTO FIXTURE. TORQUE FASTENERS TO VALUE SHOWN.
3. STOP AS REQUIRED TO REVIEW AND INSPECT ANY UNEXPECTED NOISES OR MOVEMENTS.
4. START TIMER, TAKE A PICTURE OF CLOCK ON FIXTURE, AND HOLD FOR (5) FIVE MINUTES. AFTER 5 MINUTES, TAKE A SECOND PICTURE OF CLOCK ON FIXTURE AND VISUALLY INSPECT FOR CRACKS, DEFORMATION, ETC.

DELIVERABLE REPORT REQUIRED. IT MUST INCLUDE:

- A) A SUMMARY OF THE TEST PROCEDURE
- B) A PICTURE OF THE ACTUAL MEASURED WEIGHT OF PROOF LOAD ON SCALE. WEIGHT MUST BE EQUAL TO OR HIGHER THAN REQUIRED WEIGHT.
- C) PICTURE OF TIMER WITH PROOF LOAD THAT SHOWS 5 MINUTES OR LONGER FOR EACH TEST.
- D) VISUAL INSPECTION RESULTS

This Drawing is the property of FLOTRON, Inc. and is not to be used, copied or reproduced in any way other than for the particular purpose for which it is provided, and when said purpose has been fulfilled, it should be destroyed or returned to FLOTRON, Inc.



2630 PROGRESS STREET
VISTA, CALIFORNIA 92081
<http://www.flotron.com>

SCALE	VARIES	SIZE	B	DRAWING NO.	8024-500PROP	SHEET	9 OF 9
-------	--------	------	----------	-------------	--------------	-------	--------