

TIPOVER: $34.78 / 49.81 = .70G$

4. OPTIONS: PROOF LOAD TEST, TOW BAR, PUSH BAR, LEVELING JACKS & ESD (BANANA PLUG / GROUNDING WIRE).
 3. FINISHES: CLEAN ROOM COMPATIBLE FINISHES "C" FINISH - SKY WHITE POWDER COAT BASE FRAME & PUSH BAR, NICKEL PLATED COMPONENTS (NO ZINC), STAINLESS STEEL FASTENERS AND MISC. HARDWARE.
 KRYTOX GPL 207 LUBRICANT ON CASTERS SWIVEL BEARINGS, SYNCO - SUPER LUBE SYNTHETIC GREASE WITH PTFE LUBRICANT ENCLOSED WITHIN JACK HOUSINGS.
 2. LOAD RATING: 2,000 LBS WITH PAYLOAD 100" ABOVE THE INTERFACE CONSIDERING A SIMULTANEOUS 1/2G SIDE LOAD (WORST CASE DIRECTION) AND A 1G VERTICAL LOAD.
 SFy=3 & SFult=5.
 1. WEIGHT IN TITLE BLOCK INCLUDES 2,000 LB PAYLOAD.
- NOTES:

PROPRIETARY

This Drawing is the property of FLOTTRON, Inc. and is not to be used, copied or reproduced in any way other than for the particular purpose for which it is provided, and when said purpose has been fulfilled, it should be destroyed or returned to FLOTTRON, Inc.

TOLERANCES UNLESS OTHERWISE SPECIFIED		FLOTTRON®		2630 PROGRESS STREET VISTA, CALIFORNIA 92081 http://www.flotron.com	
FRACTION	DEC.	ANGLES			
±.03	±.010	±5°			
XX	XXX	XXX			
APPROVALS	DATE				
DRAWN	DP				
CHECKED	DATE				
MFG					
STATUS					
Released	WT: N/A	SCALE	SIZE	DRAWING NO.	REV
		1 : 12	D	8049-000PROP	-
					SHEET 1 OF 3

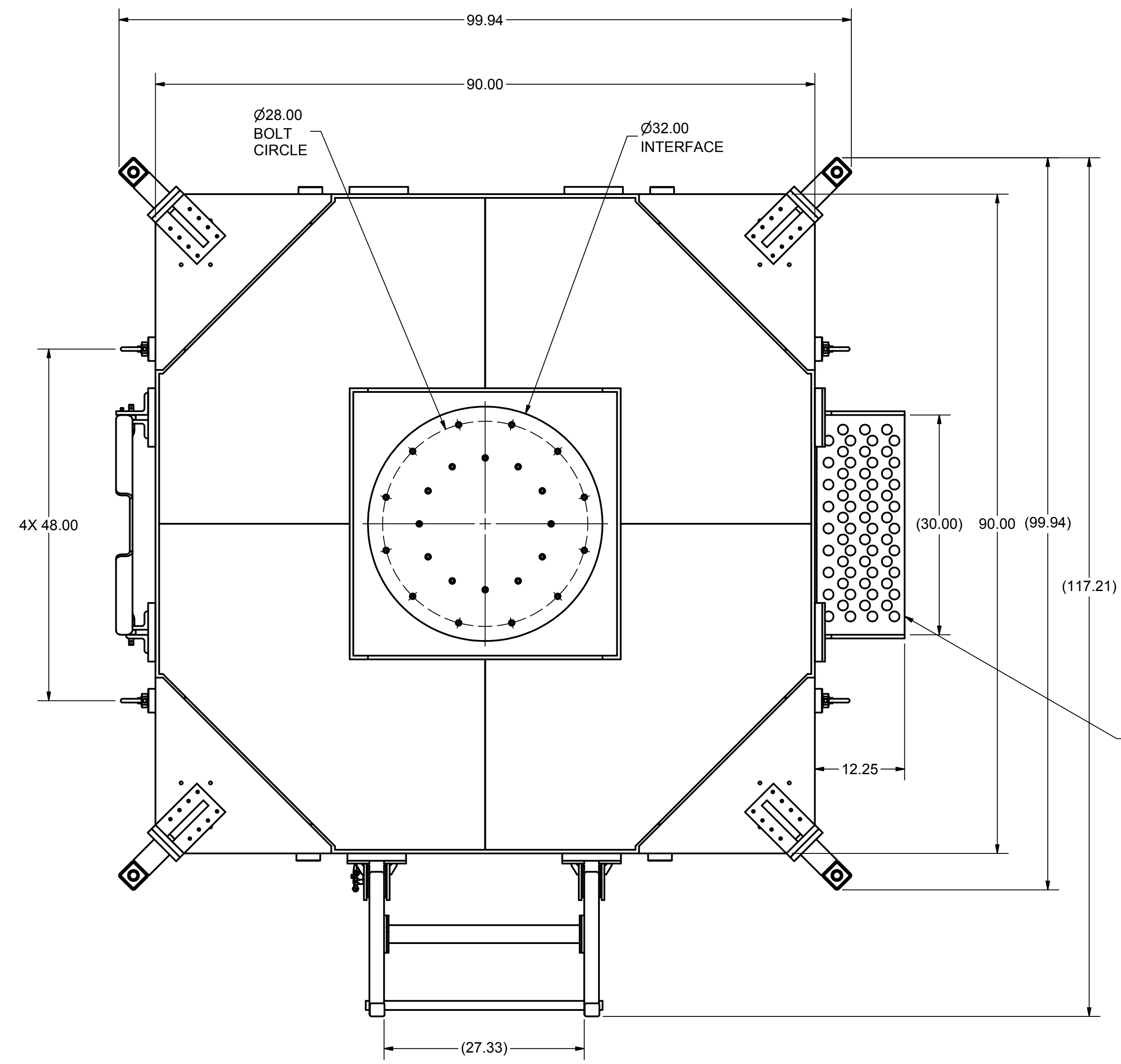

REMOVABLE STEP (OPTIONAL)

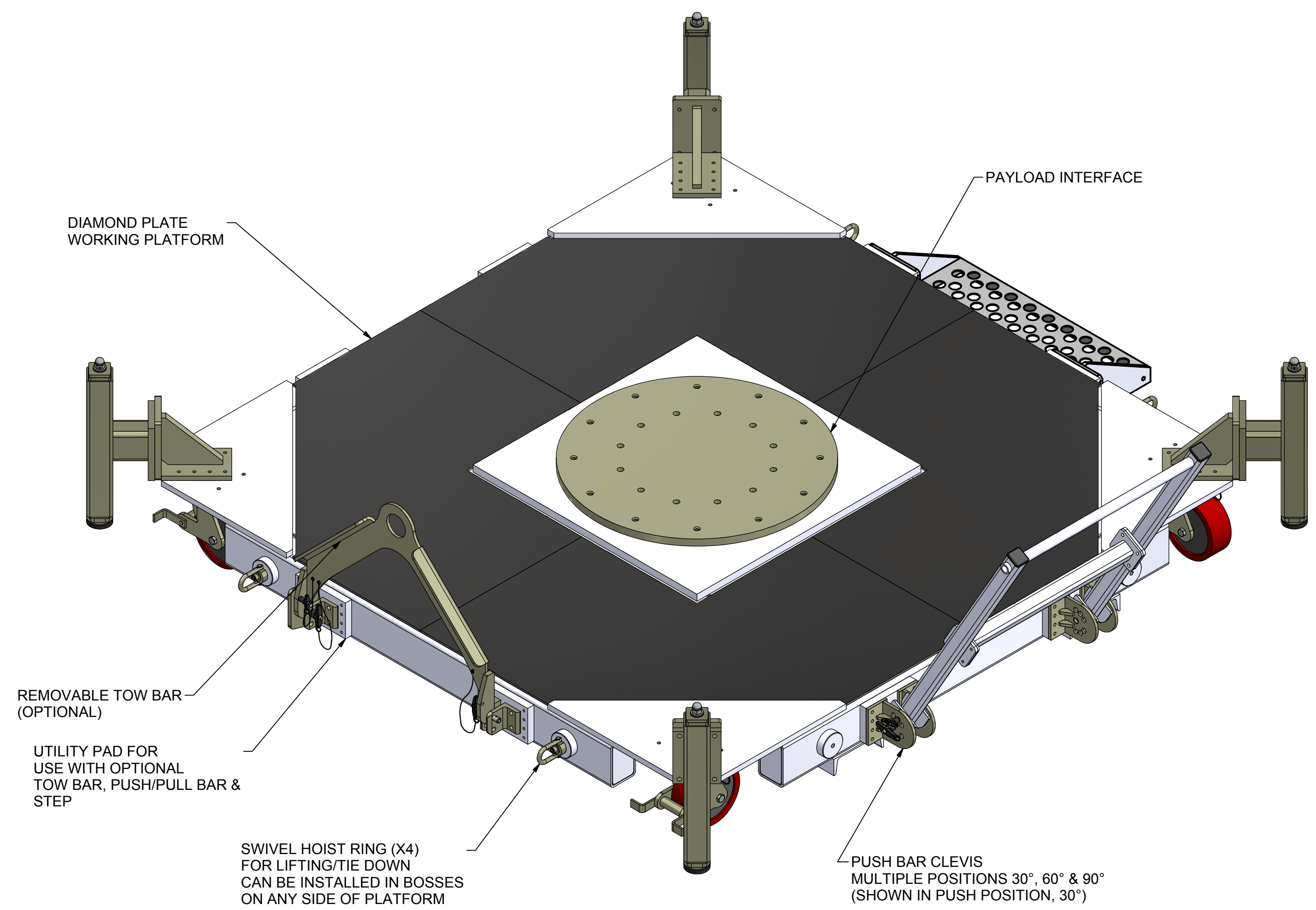

This Drawing is the property of FLOTRON, Inc. and is not to be used, copied or reproduced in any way other than for the particular purpose for which it is provided, and when said purpose has been fulfilled, it should be destroyed or returned to FLOTRON, Inc.

		2630 PROGRESS STREET VISTA, CALIFORNIA 92081 http://www.flotron.com	
SCALE	SIZE	DRAWING NO.	REV
1 : 12	D	8049-000PROP	-
SHEET			2 OF 3

OPTIONAL PROOF LOAD TEST PROCEDURE

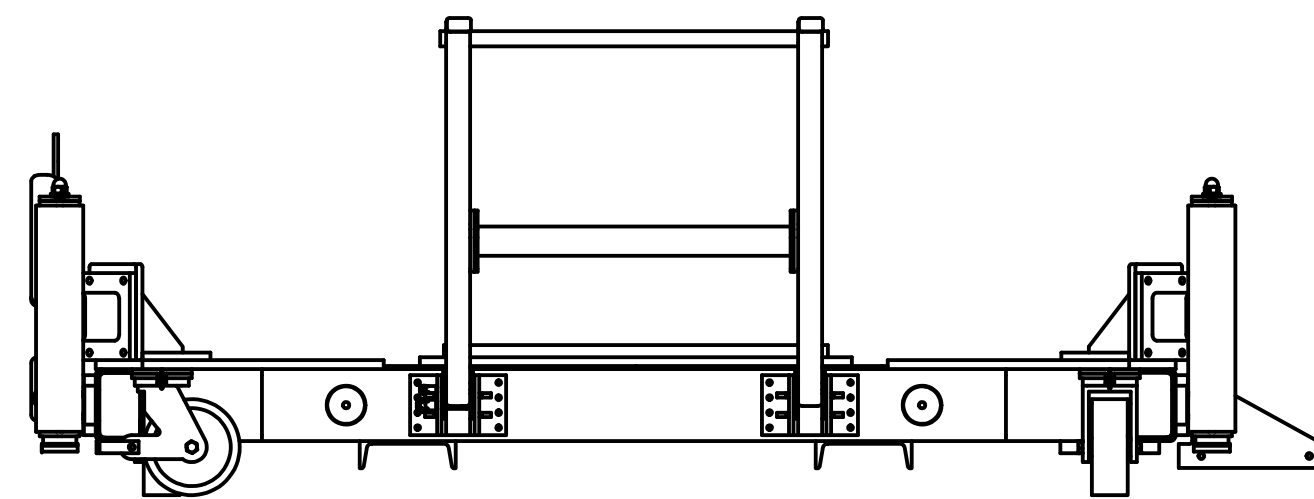
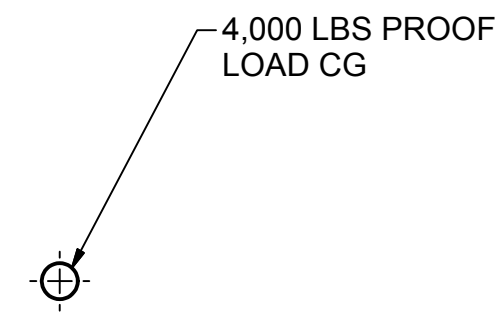

PROOF LOAD TEST / INSPECTION

1. STATIC PROOF LOAD TEST
2. 200% VERTICAL LOAD
3. HOLD FOR 5 MINUTES MINIMUM
4. CUSTOMER MAY WITNESS TEST
5. PAINT AND PLATING COVERS ALL WELDS
6. VISUALLY INSPECT FOR CRACKS, DEFORMATION, ETC.

This Drawing is the property of FLOTRON, Inc. and is not to be used, copied or reproduced in any way other than for the particular purpose for which it is provided, and when said purpose has been fulfilled, it should be destroyed or returned to FLOTRON, Inc.

		2630 PROGRESS STREET VISTA, CALIFORNIA 92081 http://www.flotron.com	
SCALE	SIZE	DRAWING NO.	REV
1 : 12	D	8049-000PROP	-
SHEET			3 OF 3