

DUAL NEEDLE ROLLER BEARINGS COME STANDARD IN NON-GEARBOX SIDE TRUNNION FOR SMOOTH, LOW FRICTION ROTATION AND LONG WEAR LIFE.

(6) SET SCREWS PER END FRAME. (4) ON TOP AND (2) ON THE SIDE. USED TO SECURE THE MAIN BEAM TO THE FRAME SLIDE TUBES. USE A 1/4 HEX KEY TO TIGHTEN.

3.00 MAX ECCENTRICITY (.80" MAX ECCENTRICITY TO MAINTAIN EASY CRANK WITH STANDARD GEARBOX) (2.88" MAX ECCENTRICITY TO MAINTAIN EASY CRANK WITH **DR3** GEARBOX)

FLYWHEEL STANDARD TO PREVENT STAIR-STEPPING (STICK-SLIP) IN GEARBOX.

(59.00) OAW (NO JACKS)

(.75)

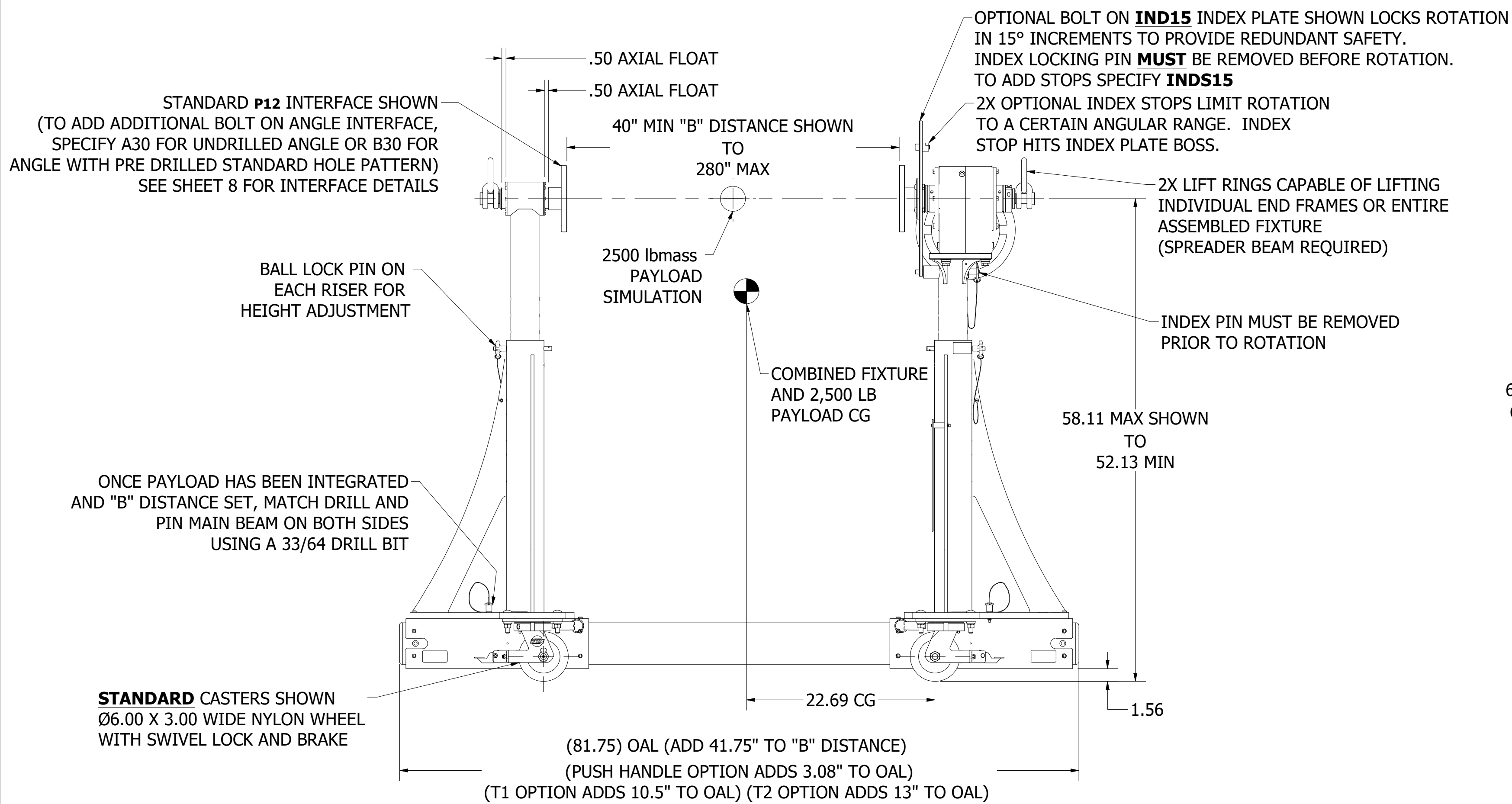

LONGITUDINAL STABILITY @ 40" "B" DISTANCE WITH 2,500 LB PAYLOAD: 22.69 / 46.97 = .48G

FLOTTRON BLUE COLOR (SHOWN) FOR "STANDARD" FINISH. FRAMES AND GEARBOX ARE SKY WHITE FOR "C" FINISH.

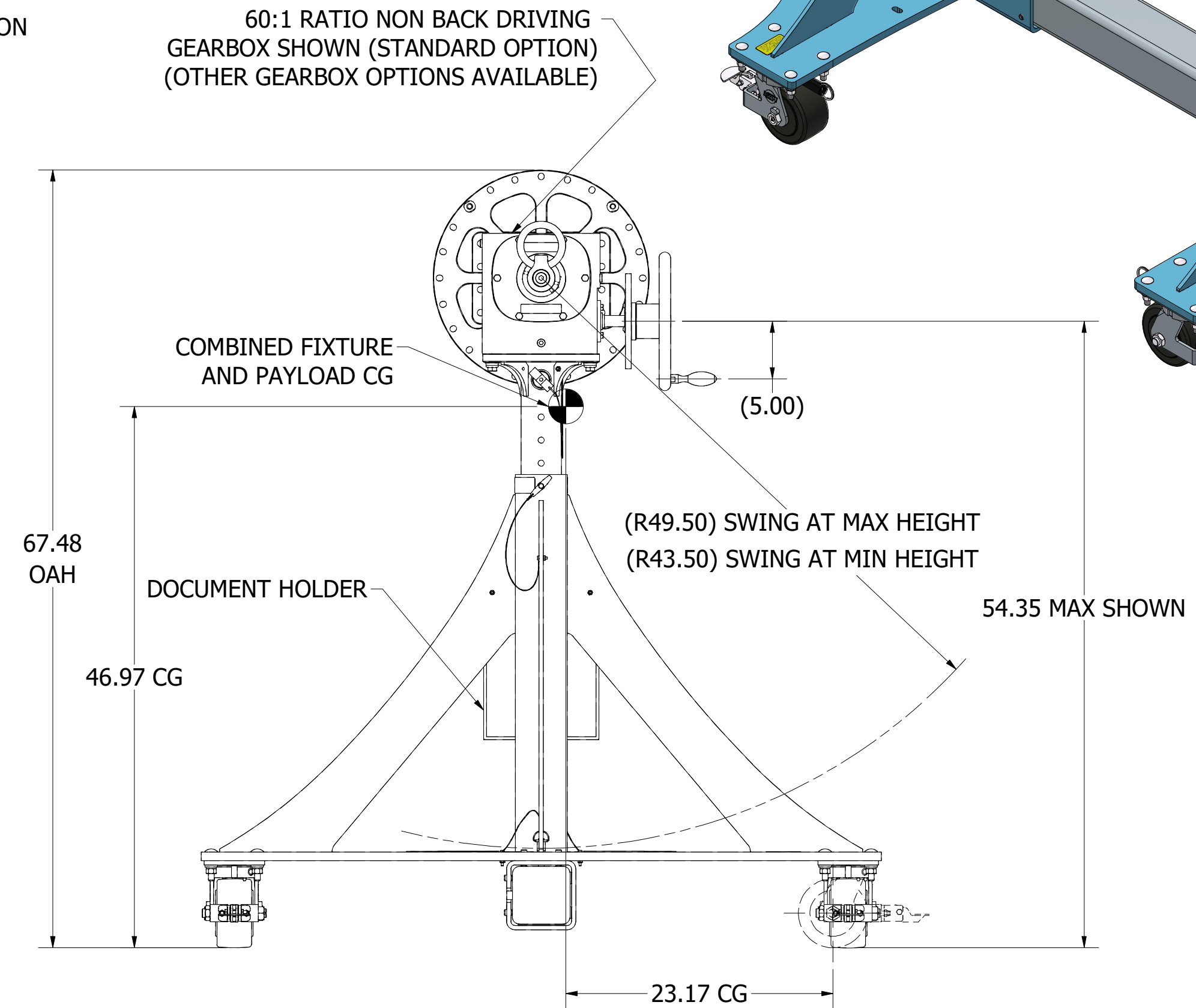
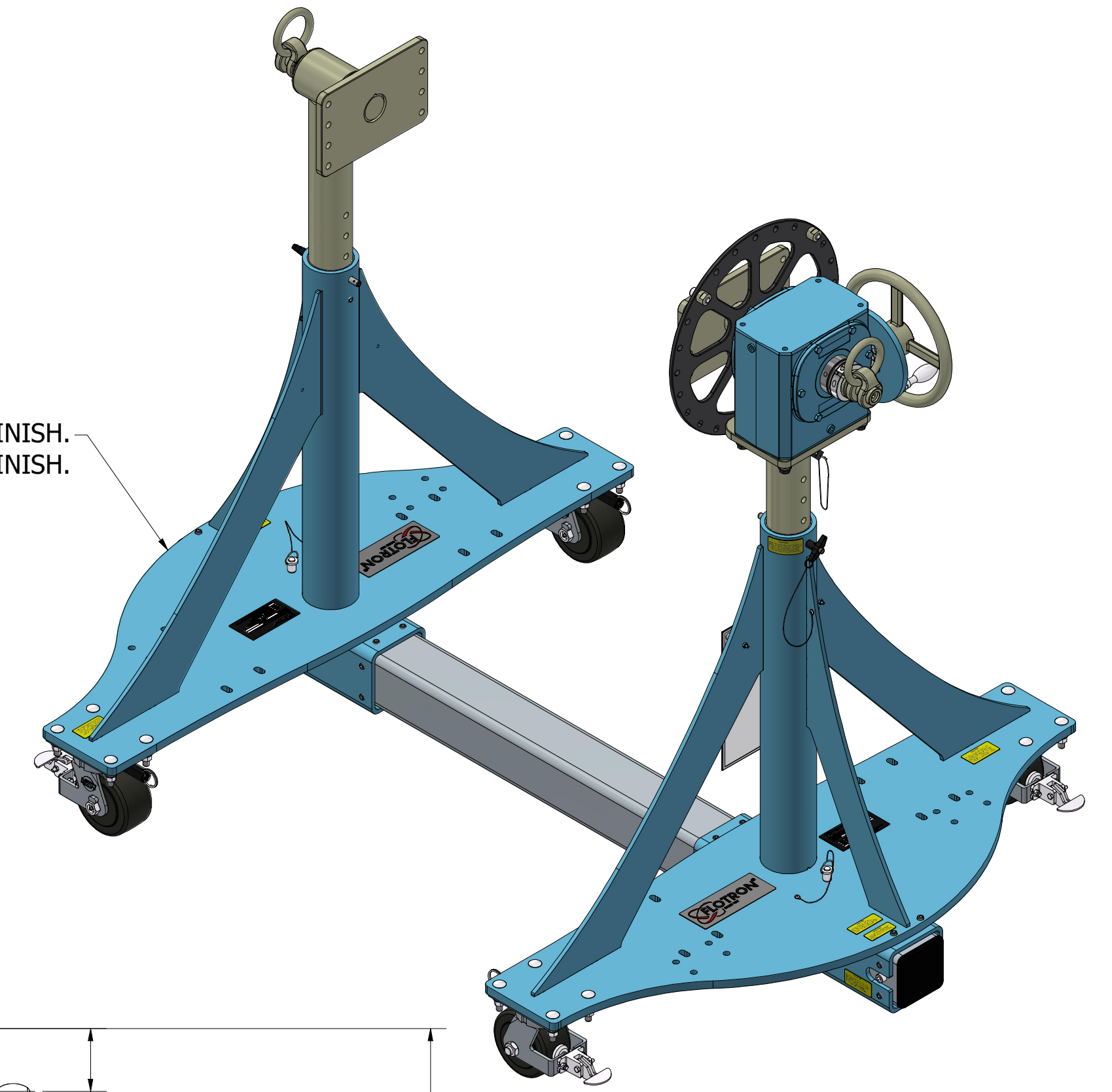

LATERAL STABILITY WITH 2,500 LB PAYLOAD: 23.17 / 46.97 = .49G

5. PROOF LOAD TEST OPTIONAL SEE SHEET 15 FOR DETAILS.
 4. CONFIGURATION SHOWN ON THIS SHEET: SFP-759-IND15-P12-B040. FOR ADDITIONAL CONFIGURATION OPTIONS SEE SHEET 3.
 3. FINISHES:
 - A. **"STANDARD"** FLOTTRON FINISHES (SHOWN) - CLASS 10K (ISO 7 CLEANROOM COMPATIBLE FINISHES) - FLOTTRON BLUE POWDER COATED END FRAMES, GEARBOX PAINTED FLOTTRON BLUE, NICKEL PLATED COMPONENTS (NO ZINC) STAINLESS STEEL OR BLACK OXIDE FASTENERS AND MISC. HARDWARE. STANDARD LUBRICANTS.
 - B. **"C"** FINISH - CLASS 1K (ISO 6 CLEANROOM COMPATIBLE FINISHES) - SKY WHITE POWDER COATED END FRAMES, GEARBOX PAINTED GLOSS WHITE EPOXY, NICKEL PLATED COMPONENTS (NO ZINC), STAINLESS STEEL FASTENERS AND MISC. HARDWARE. OPEN-ENDED TUBES NICKEL PLATED (EXCEPT FORKLIFT TUBES). KRYTOX GPL 207 LUBRICANT ON CASTER SWIVEL BEARINGS, TRUNNION SHAFTS, AND JACKS (IF APPLICABLE).
 2. LOAD RATING: 2,500 LBS @ 3.00" MAX ECCENTRICITY CONSIDERING A SIMULTANEOUS 1/2G SIDE LOAD (WORST CASE DIRECTION) AND A 1G VERTICAL LOAD. SFy=3 & SFult=5. MAX TORQUE ON GEARBOX 7,500 IN-LBS (2,000 IN-LBS MAX EASY CRANK FOR 60:1 **STANDARD** GEARBOX AND 7,200 IN-LB FOR 300:1 **DR3** GEARBOX)
 1. WEIGHT IN TITLE BLOCK INCLUDES 2,500 LB PAYLOAD.
- NOTES:

PROPRIETARY This Drawing is the property of FLOTTRON, Inc. and is not to be used, copied or reproduced in any way other than for the particular purpose for which it is provided, and when said purpose has been fulfilled, it should be destroyed or returned to FLOTTRON, Inc.	<small>UNLESS OTHERWISE SPECIFIED DIMENSIONS ARE IN INCHES</small> <small>LINEAR TOLERANCES: ±.03 .XX</small> <small>ANGULAR TOLERANCES: ±.5° .XXX</small>		2630 PROGRESS STREET VISTA, CALIFORNIA 92081 http://www.flotron.com
	<small>DO NOT SCALE DRAWING INTERPRET DIMENSIONING AND TOLERANCING PER ASME Y14.5-2018 INTERPRET DWG. PER ASME Y14.100</small>		
SCALE: 1 : 10 SIZE: D DRAWING NO.: 8053-600PROP		SFP-759	
WT: 3639.3 lbmass Cad software: Inventor		SHEET 1 OF 15	

SFP-747 & SFP-759 SERIES OPTIONS COMPATIBILITY MATRIX

		SIZE		LIFT		BATTERY POWERED		FORKLIFT TUBES		JACKS		PUSH BAR		GEARBOX			CORDLESS HAND DRILL		INDEX PLATE			TOWING INTERFACE			SECONDARY AXIS OF ROTATION CRADLE		
		SFP-747	SFP-759	BLANK	EML	BLANK	BAT	BLANK	F1	BLANK	J5	BLANK	P1	BLANK	DR3	DR6	BLANK	D	BLANK	IND15	INDS15	BLANK	T1	T2	T3	BLANK	SA1-SA8
SIZE	SFP-747																									X	
	SFP-759																										
LIFT	BLANK - STANDARD						X																				
	EML								X			X											X	X			
BATTERY POWERED	BLANK - NO BATTERY																										
	BAT			X																							
FORKLIFT TUBES	BLANK - NO TUBES																										
	F1				X																				X		
JACKS	BLANK - NO JACKS																										
	J5																								X (4)		
PUSH BAR	BLANK - NO PUSH BAR																										
	P1				X																						
GEARBOX	BLANK - STANDARD														-		X										-
	DR3																										-
	DR6																										
CORDLESS HAND DRILL	BLANK - NO DRILL																										
	D												X	-													-
INDEX PLATE	BLANK - NO INDEX																										
	IND15																										
	INDS15																										
TOWING INTERFACE	BLANK - NO TOW																										
	T1				X																						
	T2				X																						
	T3								X		X (4)																
SECONDARY AXIS OF ROTATION CRADLE	BLANK - NO CRADLE																										
	SA1-SA8	X																									
NOTE:		1. OPTIONS SHOWN AS X ARE NOT COMPATIBLE WITH OTHER OPTIONS																									
		2. OPTIONS SHOWN AS - ARE COMPATIBLE WITH OTHER OPTIONS BUT NOT RECOMMENDED. CONTACT FLOTRON FOR FURTHER DETAILS AND EXPLANATION OF CONCERNS/RISKS																									
		3. OPTIONS NOT SHOWN IN THIS MATRIX ARE COMPATIBLE WITH ALL OTHER OPTIONS																									
		4. JACKS WITH T3 OPTION ARE COMPATIBLE WITH SFP-759 ONLY																									

This Drawing is the property of FLOTRON, Inc. and is not to be used, copied or reproduced in any way other than for the particular purpose for which it is provided, and when said purpose has been fulfilled, it should be destroyed or returned to FLOTRON, Inc.

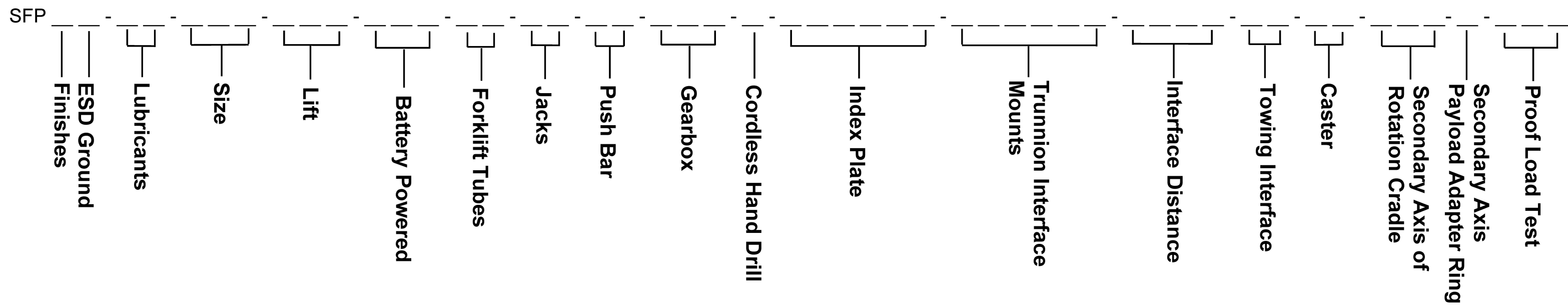

Finishes

(blank) - Standard finishes (No Zinc)
 C - - - - Clean room finishes

ESD Ground

(blank) - No ESD ground
 E - - - - Ground lug and drag chain for use in EPA's

Lubricants

(blank) - Standard lubricants
 L1 - - - - Trunnions, caster swivel bearings, and jacks (if applicable) lubricated with Krytox GPL 207
 L2 - - - - Trunnions, caster swivel bearings, and jacks (if applicable) lubricated with Braycote 601EF
 NOTE: "C" finish includes L1 lubricants except in jack screw threads.

Size

747 - - - 47" wide frame; 30.5"-36.5" max payload swing radius; 2,500 lb. capacity
 759 - - - 59" wide frame; 43.5" - 49.5" max payload swing radius; 2,500 lb. capacity

Lift

(blank) - Risers pinned at 2" increments (overhead lift req)
 EML - - - Electromechanical Lift. This option increases lift range and max swing radius. See proposal drawing for details.

Battery Powered

(blank) - No battery
 BAT - - - Battery powered lift for EML option

Forklift Tubes

(blank) - No forklift tubes
 F1 - - - - Frame mounted forklift tubes (not available for "B" distances over 150". Inside of tubes not fully plated (Even for "C" finish)

Jacks

(blank) - No jacks provided
 J5 - - - - Jacks with hex drive

Push Bar

(blank) - No push bar
 P1 - - - - Non-gearbox side riser mounted push bar (Can mount to gearbox side riser but only in highest two interface height pin positions)

Gearbox

(blank) - 60:1 ratio standard gearbox
 DR3 - - - 300:1 ratio double reduction stairstep resistant Gearbox. Recommended for torques higher than 2,000in-lbs.
 DR6 - - - 600:1 ratio double reduction stairstep resistant Gearbox. Must select "D" drill drive option.

Cordless Drill Drive Input

(blank) - No hand drill
 D - - - - Battery powered right angle drill permanently Mounted to gearbox input shaft (Must select DR6 Gearbox option)

Proof Load Test

(blank) - - No proof load test
 PLT - - - - Standard proof load Test (includes deliverable report)

Secondary Axis Payload Adapter Ring

(blank) - No adapter ring for secondary axis of rotation cradle.
 Standard SA interface comes with 36X ¼-28 threaded holes on a Ø24" bolt circle (ESPA Grande)
 R - - - - Adapter ring to convert SA interface holes to 36X Ø.281 thru holes on a Ø24" bolt circle (ESPA Grande)

Secondary Axis of Rotation Cradle

(blank) - - No secondary axis of rotation
 SA1 - - - - Secondary axis of rotation (Bolt Position 1)
 SA2 - - - - Secondary axis of rotation (Bolt Position 2)
 SA3 - - - - Secondary axis of rotation (Bolt Position 3)
 SA4 - - - - Secondary axis of rotation (Bolt Position 4)
 SA5 - - - - Secondary axis of rotation (Bolt Position 5)
 SA6 - - - - Secondary axis of rotation (Bolt Position 6)
 SA7 - - - - Secondary axis of rotation (Bolt Position 7)
 SA8 - - - - Secondary axis of rotation (Bolt Position 8)
 NOTE: NOT COMPATIBLE WITH SIZE 747

See proposal drawing to determine correct bolt position. Bolt positions can be changed in the field, but bolt position selected will be the bolt position fixture is shipped with. Must select B120 interface distance when specifying standard length cradle. Special length cradles available upon request in increments of 20". To get most capability out of SA option and for best operator experience, "DR6" gearbox with drill drive input ("D" Option) is highly recommended. Option reduces load capacity to 1,800 lbs cantilevered 33" max from interface.

Caster

(blank) - - Standard Ø6" nylon casters with swivel locks and brakes
 C1 - - - - Ø8" nylon casters with swivel locks and brakes

Towing Interface

(blank) - - No towing interface
 T1 - - - - Removable lunette ring towing interface (attaches to main beam)
 T2 - - - - Removable ball coupler towing interface (attaches to main beam)
 T3 - - - - Removable tow bar (attaches to end frames)
 NOTE: T3 option is not compatible with jacks (J5 option) for 747 size.

Interface Distance

B"XXX"- - Interface distance where "XXX" = length in inches between trunnion interface mounts. (1" increments within the following range)

SIZE	MIN	MAX
SFP-747	30"	280"
SFP-759	40"	280"

Trunnion Interface Mounts

P12 - - - - 8" x 12" mounting plate
 P12/A30 - P12 (8" x 12") mounting plate with A30 angle (No mounting holes) bolted to P12.
 P12/B30 - P12 (8" x 12") mounting plate with B30 angle (Standard mtg. hole pattern) bolted to P12.

NOTE: Special angle interface lengths available upon request.

Index Plate

(blank) - - No index plate
 IND15 - - 15° index plate
 INDS15 - 15° index plate with index stops
 NOTE: Special index plate hole spacing available upon request.

Example:

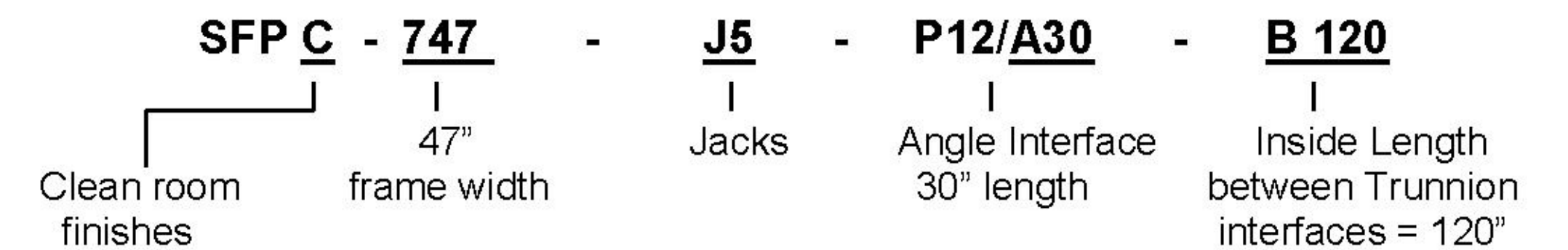

SFP-700 SERIES CREATING A MODEL NUMBER

This Drawing is the property of FLOTRON, Inc. and is not to be used, copied or reproduced in any way other than for the particular purpose for which it is provided, and when said purpose has been fulfilled, it should be destroyed or returned to FLOTRON, Inc.

		2630 PROGRESS STREET VISTA, CALIFORNIA 92081 http://www.flotron.com		
		SCALE	SIZE	DRAWING NO.
1 : 10		D	8053-600PROP	
			SHEET	3 OF 15

EML (ELECTROMECHANICAL LIFT) OPTION

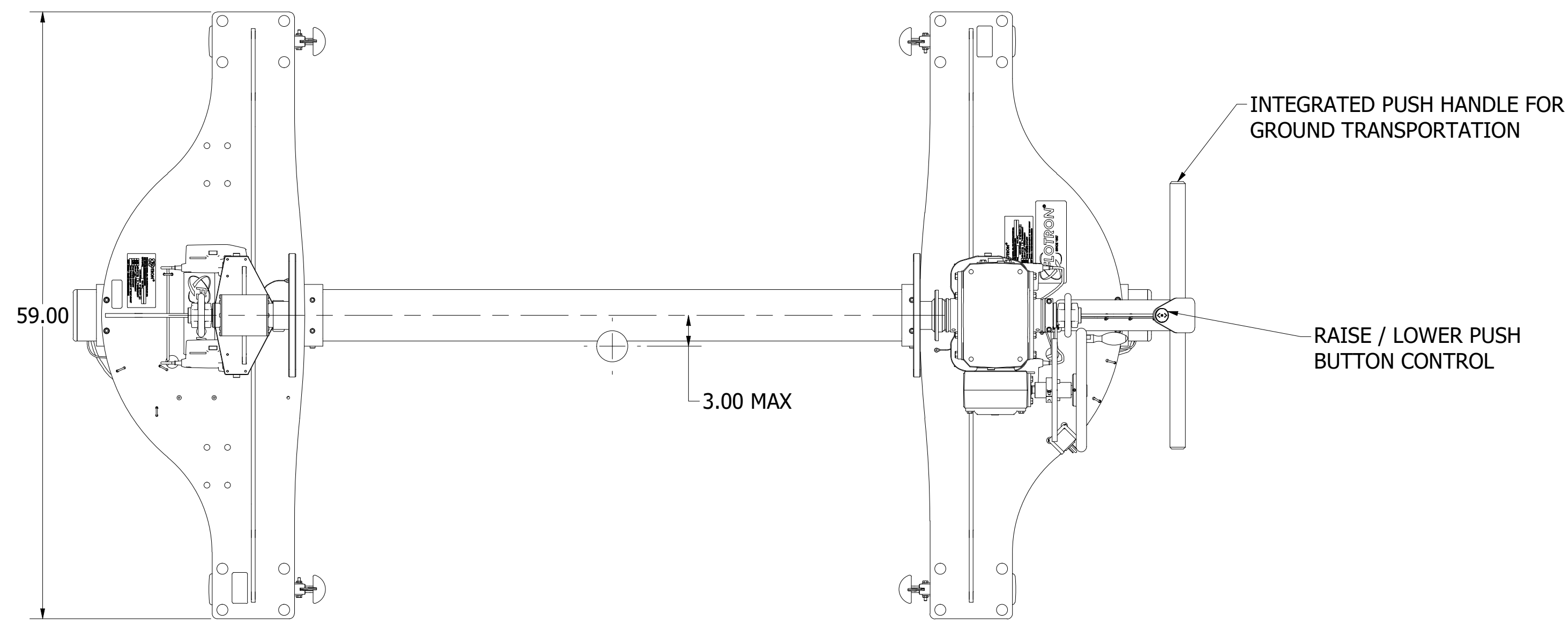

"C" FINISH OPTION COMES WITH BELLOWS COVERS (NOT SHOWN) TO PROTECT FROM CONTAMINATION DUE TO LIGHT COATING OF OIL ON ACTUATOR RODS.

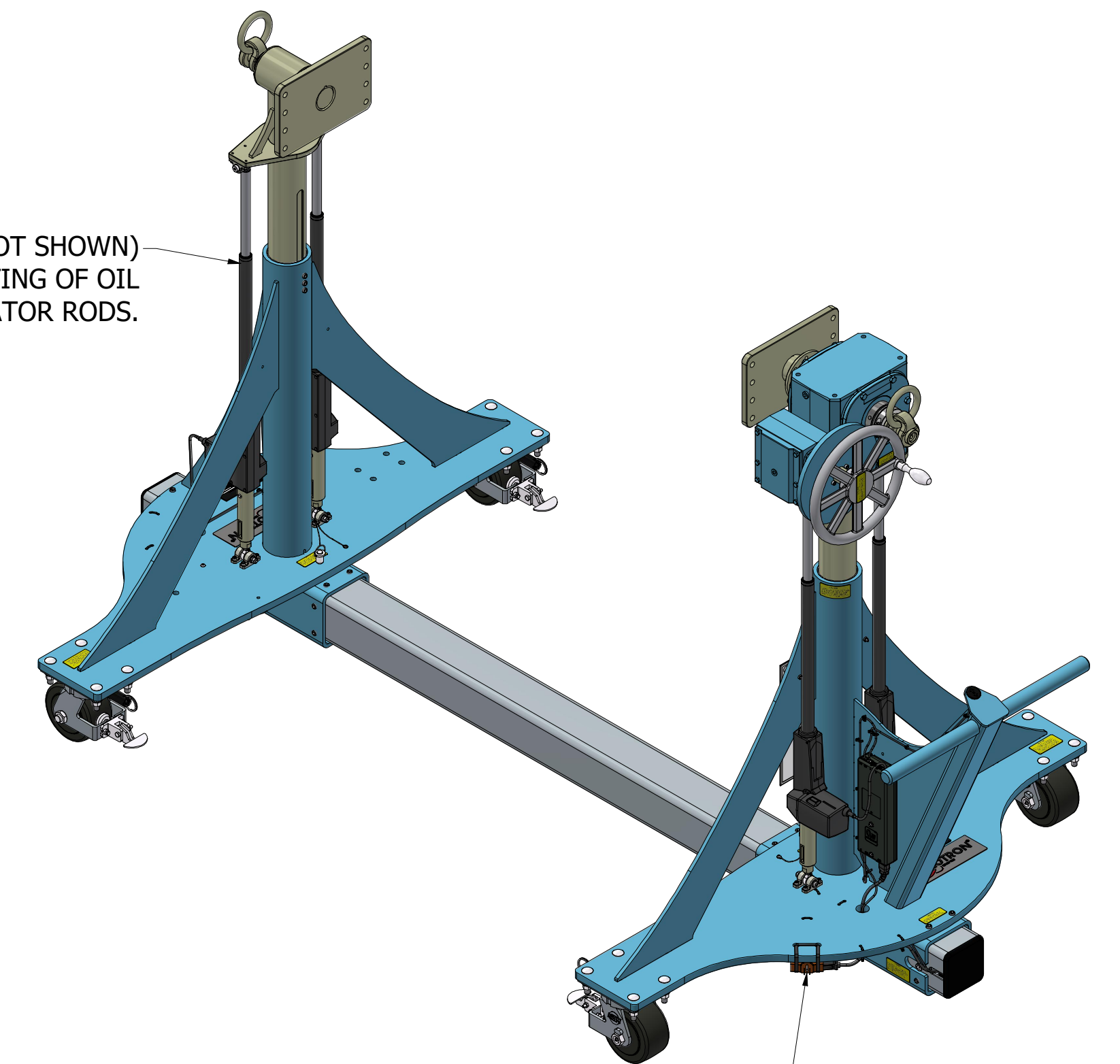

POWER PLUG (EXTENSION CORD REQ'D - NOT PROVIDED)

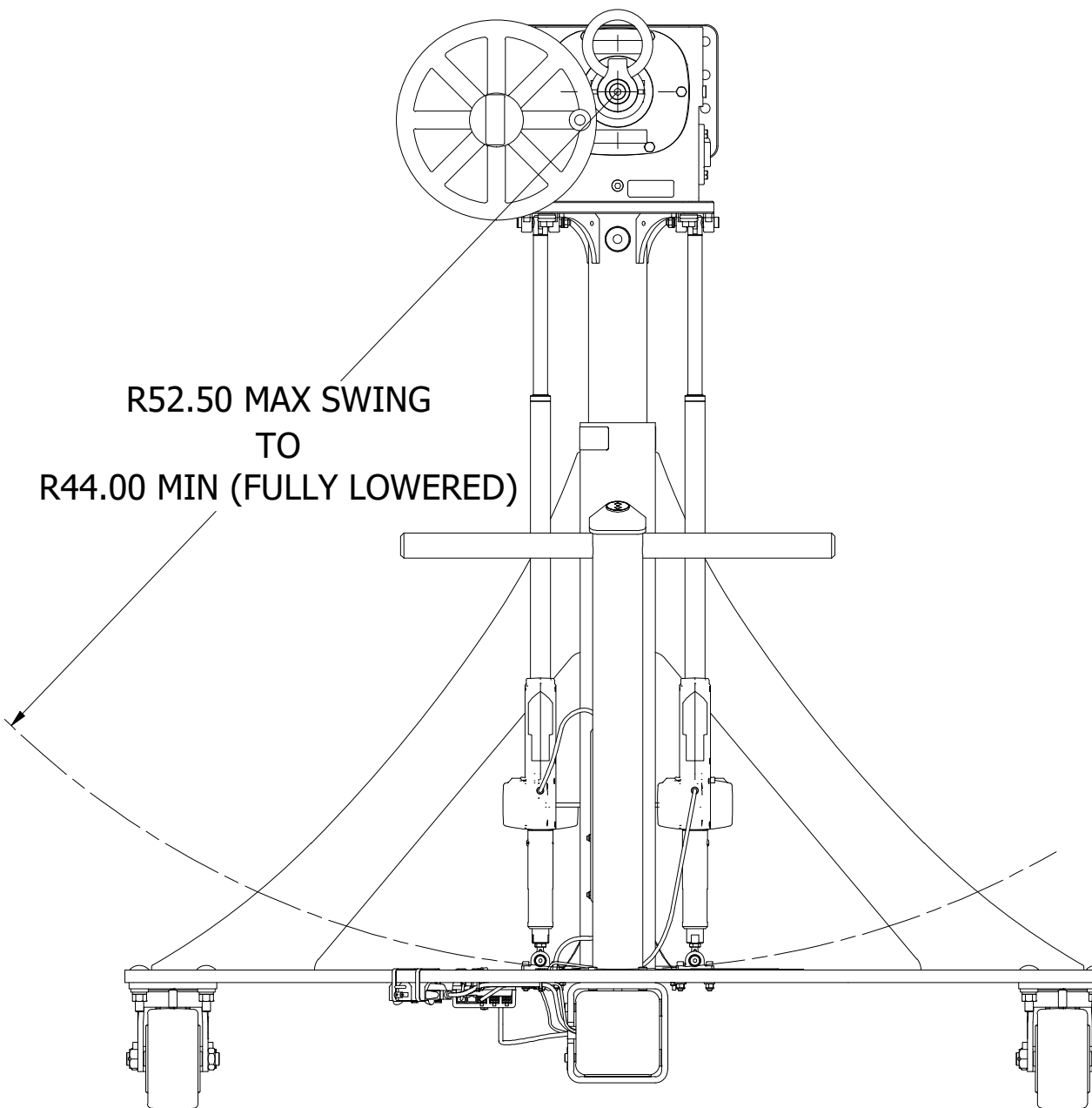
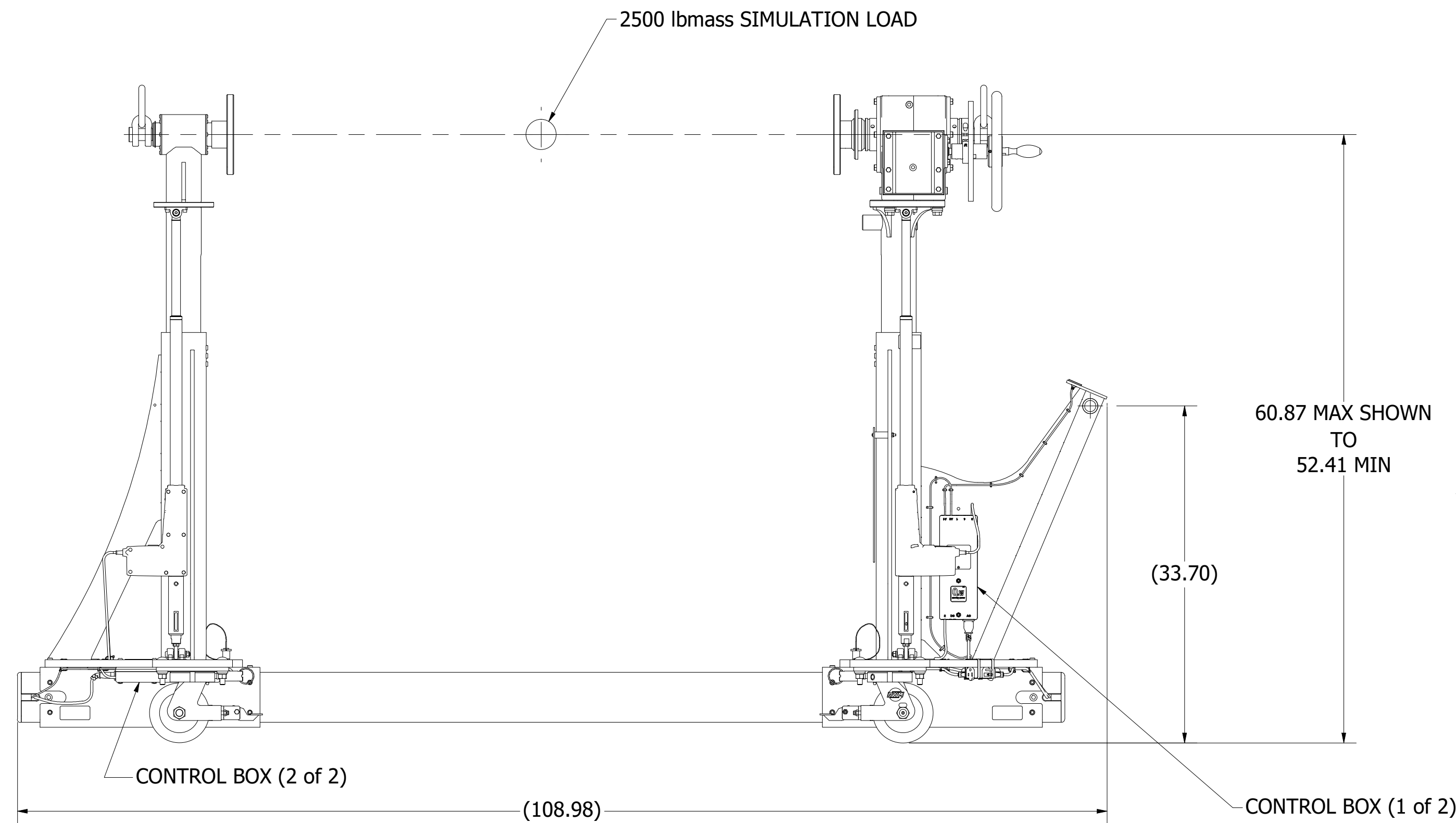

BAT BATTERY POWERED OPTION

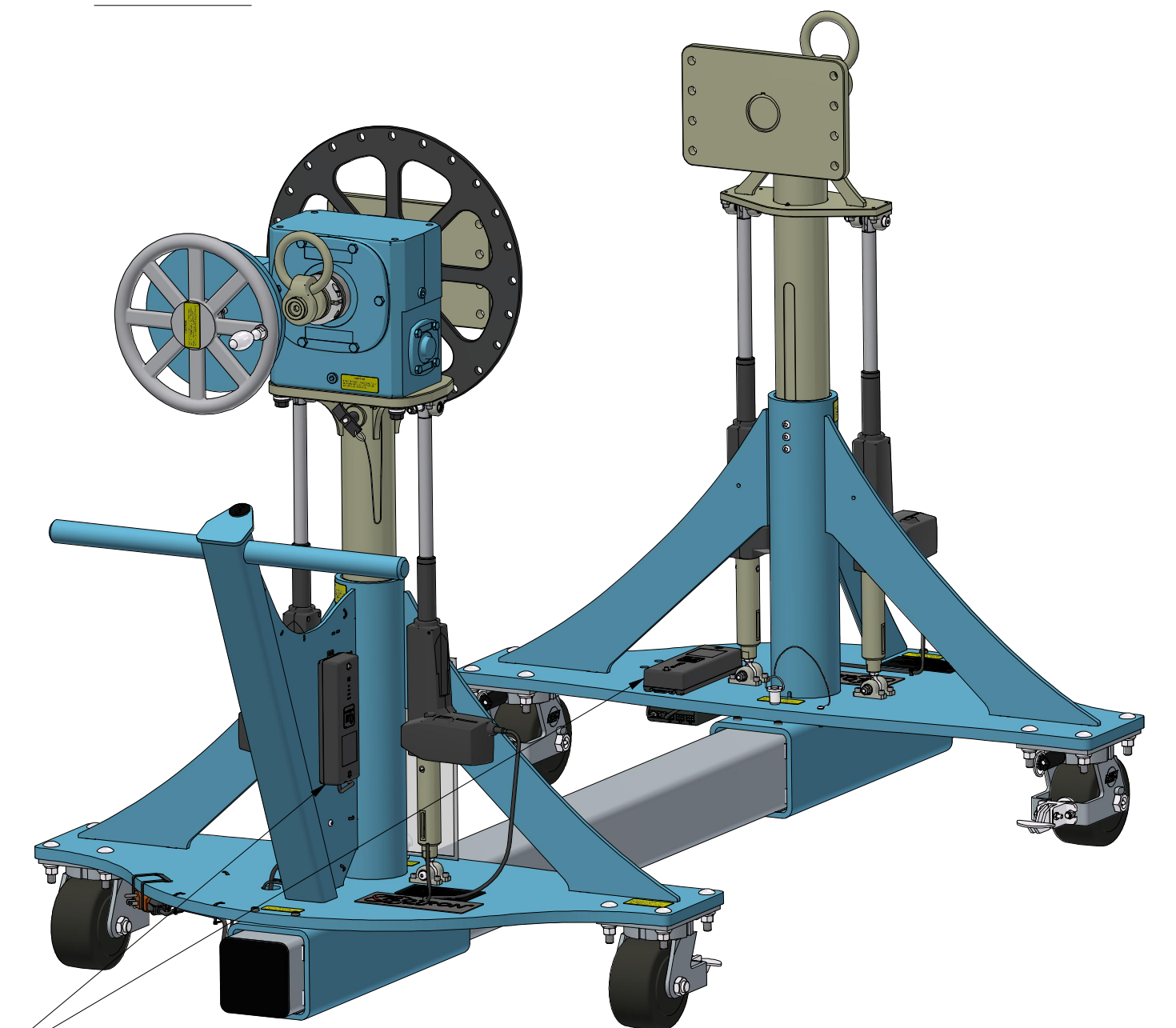

TWO BATTERIES ARE PROVIDED, MOUNTED OPPOSITE TO THE CONTROL BOXES. THESE BATTERIES FACILITATE MULTIPLE LIFT AND LOWER CYCLES BEFORE REQUIRING A CHARGE. THE PRECISE NUMBER OF CYCLES DEPENDS ON VARIOUS FACTORS SUCH AS THE PAYLOAD WEIGHT, LOAD ECCENTRICITY, AMBIENT TEMPERATURE, BATTERY AGE, AND LIFT DISTANCE. NONETHELESS, IT IS ESTIMATED THAT THE TOTAL NUMBER OF LIFT/LOWER CYCLES WITH A FULL PAYLOAD WEIGHT IS APPROXIMATELY EIGHT. THE BATTERIES CAN BE CHARGED THROUGH THE CONTROL BOX OR CAN BE DETACHED AND CHARGED THROUGH A SEPARATE LINAK SMPS006 CHARGER (SOLD SEPARATELY). TO ENSURE THAT THERE IS ALWAYS A CHARGED BATTERY AVAILABLE, AN ADDITIONAL BATTERY AND SMPS006 CHARGER CAN BE ORDERED. FOR FURTHER DETAILS REGARDING THE BATTERY, PLEASE REFER TO THE LINAK BA001 USER MANUAL AVAILABLE ONLINE.

10. MIN/MAX TEMPERATURE FOR ELECTRICAL COMPONENTS: +41°F TO +104°F
9. UNIT WILL RETAIN POSITION WHEN TURNED OFF SO NO HOMING FUNCTION IS NECESSARY DURING NORMAL USE.
8. NOISE LEVEL: 48dB(A); MEASURING METHOD DS/EN ISO 3743-1, WHEN ACTUATORS ARE NOT LOADED.
7. DUTY CYCLE: MAX 10% OR 2 MINUTES CONTINUOUS USE FOLLOWED BY 18 MINUTES NOT IN USE.
6. THE RAISE AND LOWER SPEED IS FIXED AT 11.5 INCHES/MINUTE AND IS NOT ADJUSTABLE. BUTTONS CAN BE JOGGED TO RAISE AND LOWER SLOWER IF DESIRED.
5. INPUT POWER: 100-240VAC, 50-60HZ, 600W. AN EXTENSION CORD (5 AMP MINIMUM RATING) IS NEEDED TO POWER UNIT (NOT PROVIDED).
3. FINISHES:
 - A. **"STANDARD"** FLOTRON FINISHES (SHOWN) - CLASS 10K (ISO 7 CLEANROOM COMPATIBLE FINISHES) - FLOTRON BLUE POWDER COATED END FRAMES, GEARBOX PAINTED FLOTRON BLUE, NICKEL PLATED COMPONENTS (NO ZINC) STAINLESS STEEL OR BLACK OXIDE FASTENERS AND MISC. HARDWARE. STANDARD LUBRICANTS.
 - B. **"C"** FINISH - CLASS 1K (ISO 6 CLEANROOM COMPATIBLE FINISHES) - SKY WHITE POWDER COATED END FRAMES, GEARBOX PAINTED GLOSS WHITE EPOXY, NICKEL PLATED COMPONENTS (NO ZINC), STAINLESS STEEL FASTENERS AND MISC. HARDWARE. OPEN-ENDED TUBES NICKEL PLATED. KRYTOX GPL 207 LUBRICANT ON CASTER SWIVEL BEARINGS, TRUNNION SHAFTS, AND JACKS (IF APPLICABLE).
3. CONFIGURATION SHOWN ON THIS SHEET: SPF-759-EML-DR3-P12-B060 FOR ADDITIONAL FIXTURE OPTINONS SEE CONFIGURATION SECTION ON SHEET 3.
2. LOAD RATING: 2,500 LBS @ 3.00" MAX ECCENTRICITY CONSIDERING A SIMULTANEOUS 1/2G SIDE LOAD (WORST CASE DIRECTION) AND A 1G VERTICAL LOAD. SFy=3 & SFult=5. MAX TORQUE ON GEARBOX 7,500 IN-LBS (2,000 IN-LBS MAX EASY CRANK FOR 60:1 **STANDARD** GEARBOX AND 7,200 IN-LB FOR 300:1 **DR3** GEARBOX)
1. WEIGHT IN TITLE BLOCK INCLUDES 2,500 LB PAYLOAD.

NOTES:

This Drawing is the property of FLOTRON, Inc. and is not to be used, copied or reproduced in any way other than for the particular purpose for which it is provided, and when said purpose has been fulfilled, it should be destroyed or returned to FLOTRON, Inc.

		2630 PROGRESS STREET VISTA, CALIFORNIA 92081 http://www.flotron.com	
		SCALE 1 : 10	SIZE D
		DRAWING NO. 8053-600PROP	REV
		SHEET 4 OF 15	

E ESD GROUNDING OPTION

ESD KIT INCLUDES TESTS FOR CONTINUITY

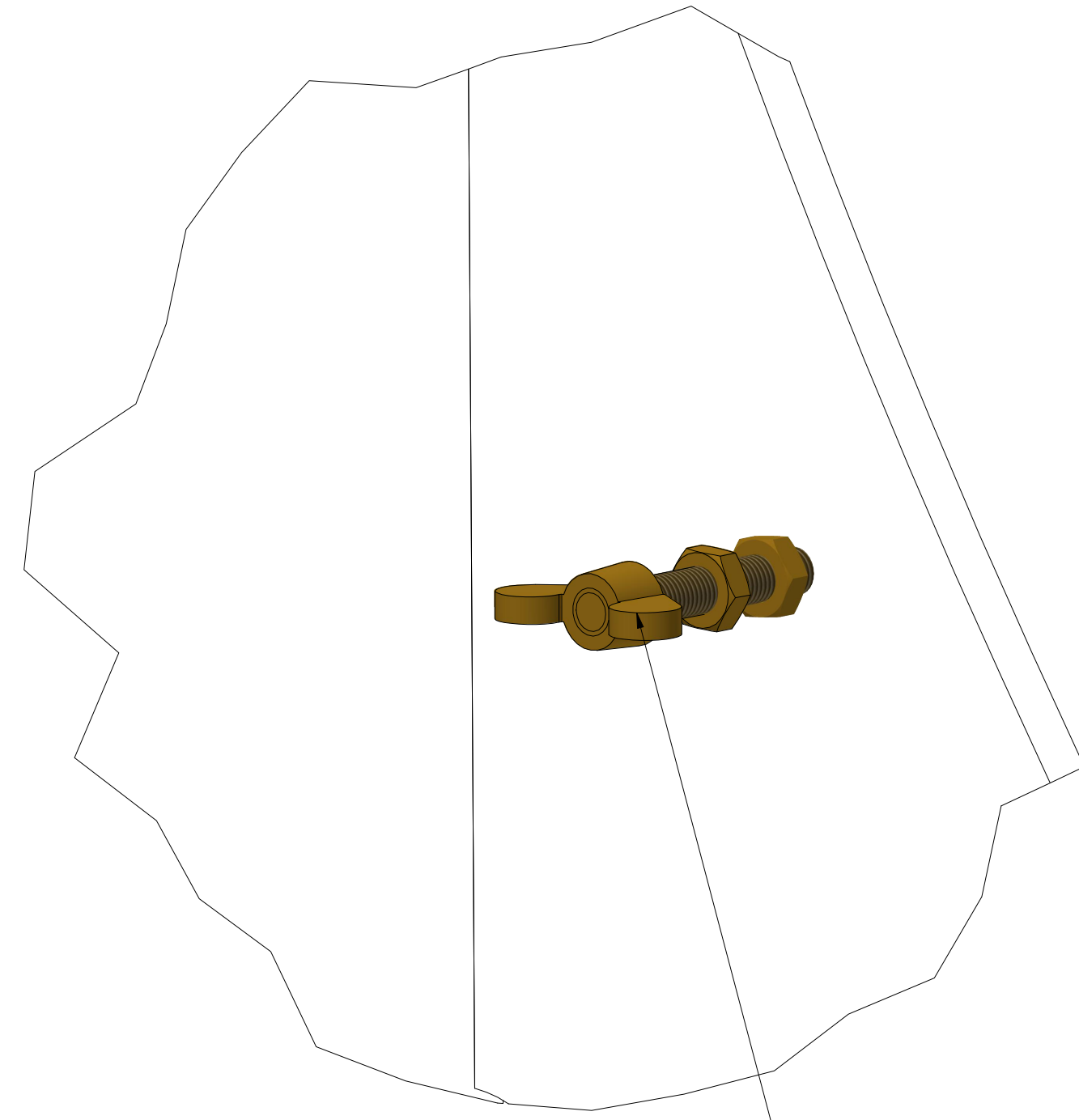

DETAIL A
SCALE 1 : 1

5/16-24 BRASS GROUNDING LUG ON ONE END FRAME

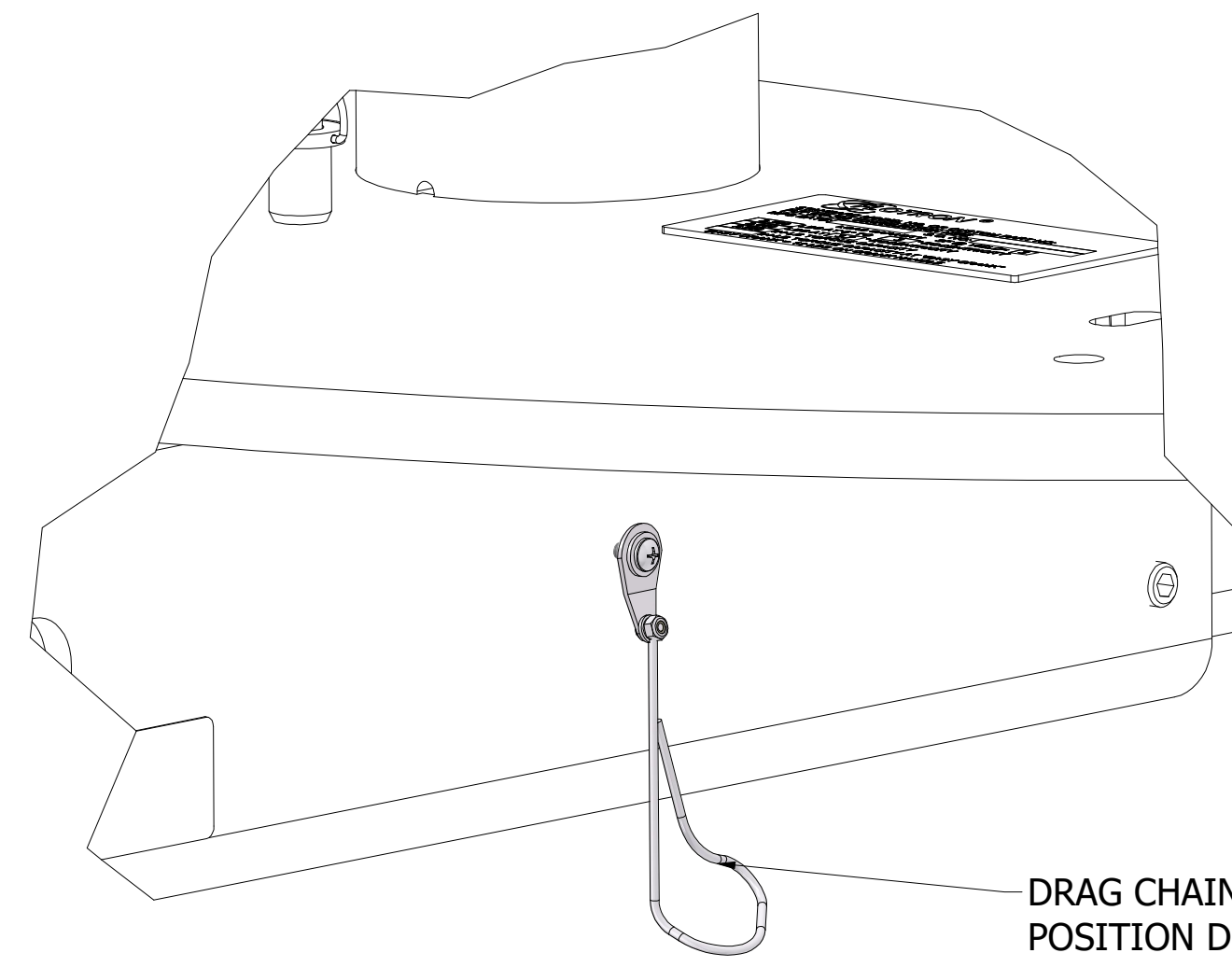

DETAIL B
SCALE 1 : 2

DRAG CHAINS CAN BE SNAPPED INTO STOWED POSITION DURING TRANSPORTATION IF DESIRED.

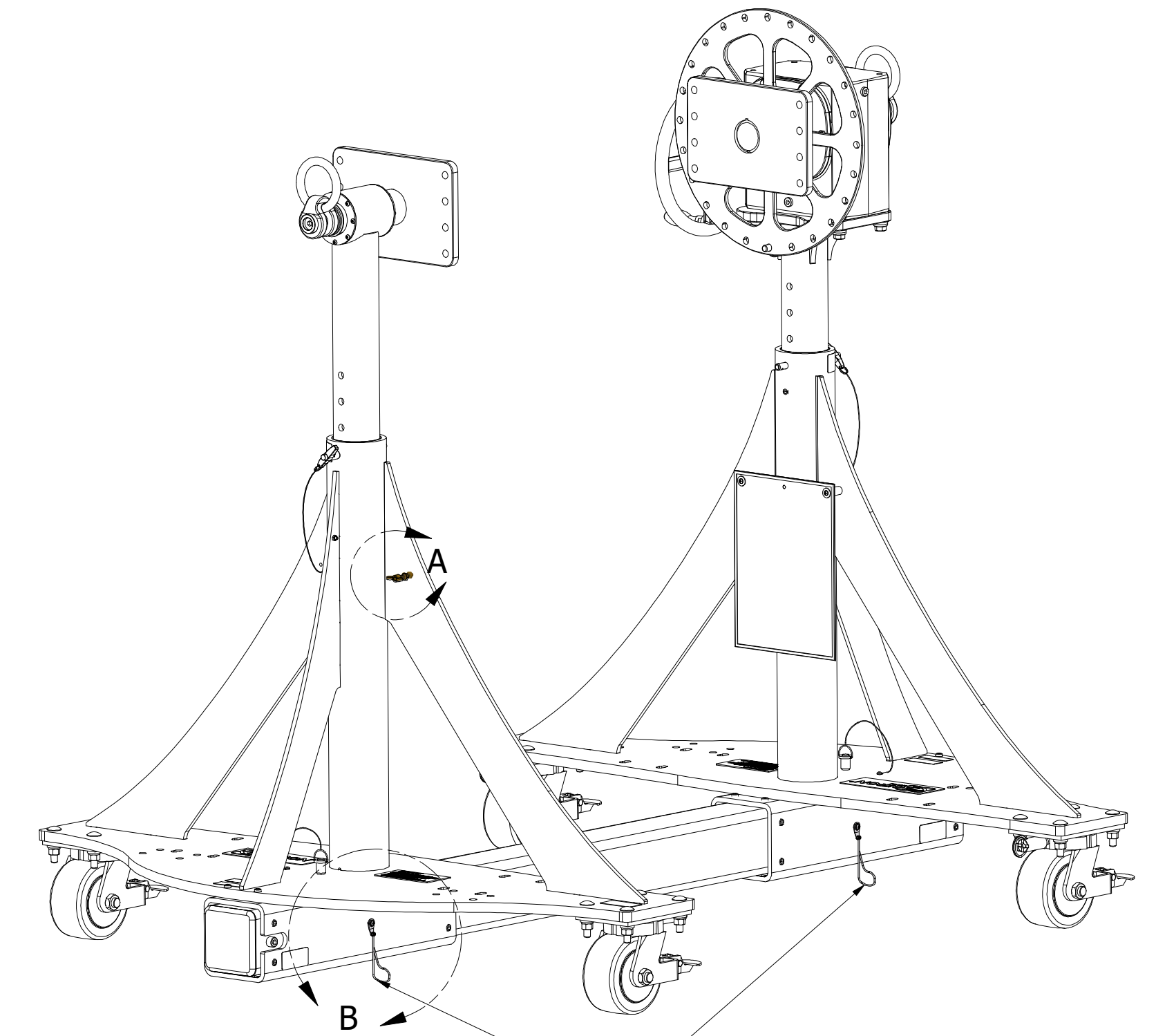

ONE DRAG CHAIN PER END FRAME TO ALLOW ESD TO GROUND

F1 FORKLIFT OPTION

(NOT RECOMMENDED FOR "C" FINISH. INSIDE WALLS OF TUBE WILL NOT BE FULLY PLATED)

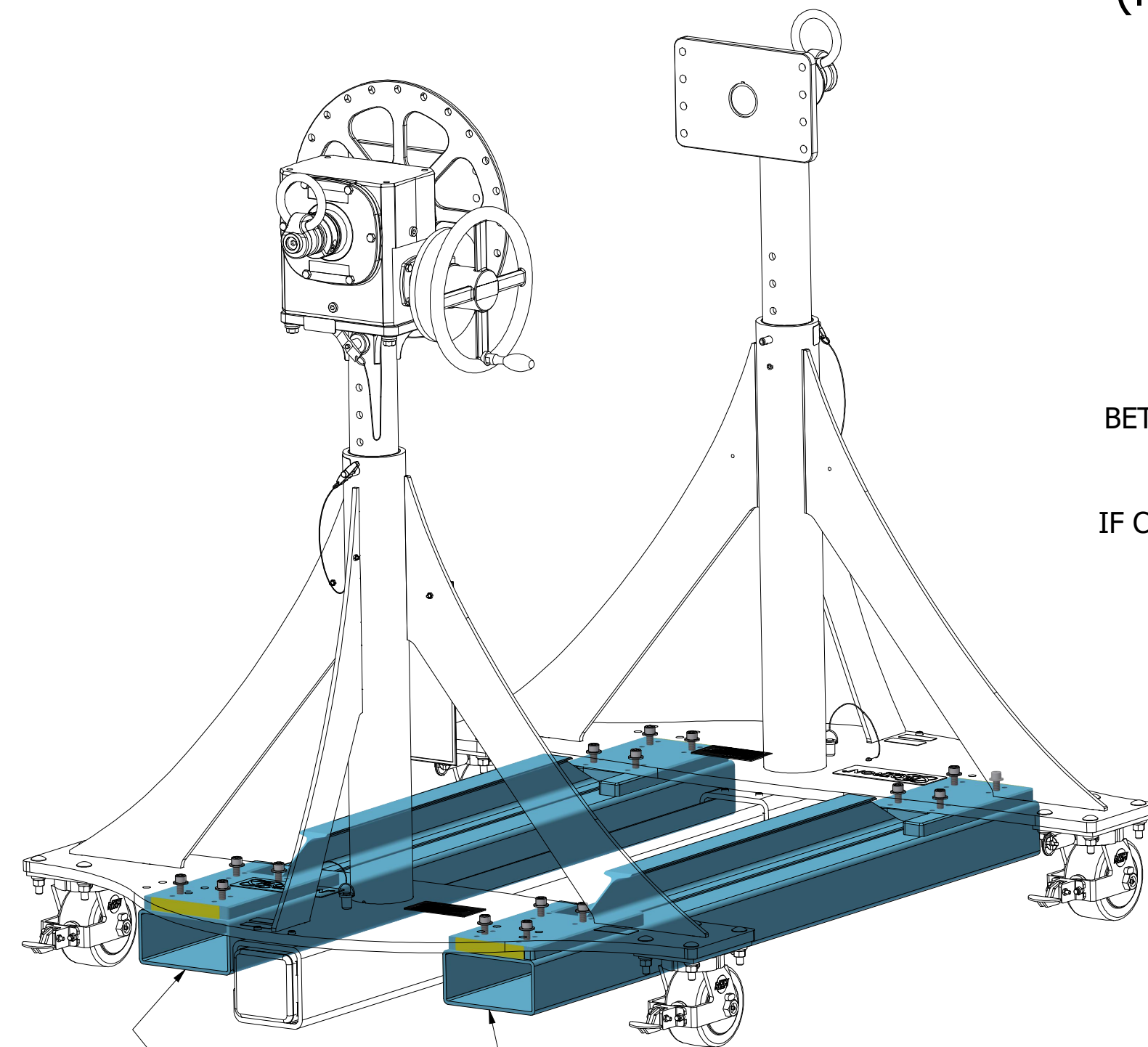

FORKLIFT FORKS SHOULD EXTEND ALL THE WAY THROUGH THE FORKLIFT TUBES IF THE PAYLOAD IS INTEGRATED AND AT LEAST A FOOT PAST THE CG OF THE FIXTURE IF LIFTING AN EMPTY FIXTURE.

FOR TYPICAL CONFIGURATION, EMPTY FIXTURE CG IS NEAR MID DISTANCE BETWEEN INTERFACES AND SLIGHTLY BIASED TOWARDS GEARBOX SIDE. EXACT CG POSITION DEPENDS ON CONFIGURATION. IF CG LOCATION OF SPECIFIC CONFIGURATION IS REQUIRED, CONTACT FLOTRON SALES.

FORKLIFT TUBES COMPATIBLE WITH "B" DISTANCE OF 40.00 MIN SHOWN TO 150.00 MAX

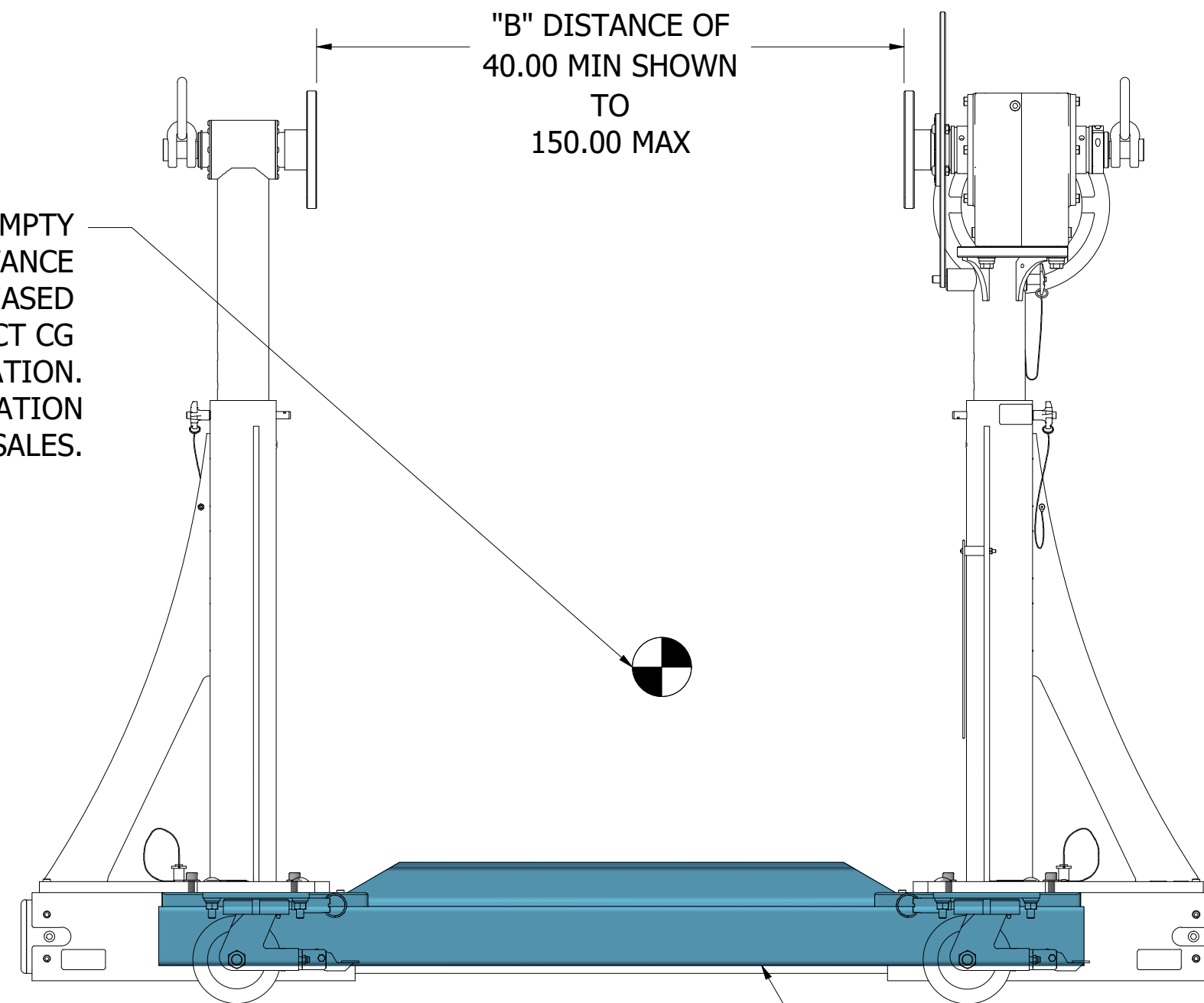

FORKLIFT TUBES CAN BE ADJUSTED +/- 1" FROM NOMINAL POSITION. AN ADDITIONAL +/- .5" FLOAT IN NON-GEARBOX SIDE TRUNNION CAN BE USED FOR FINE "B" DISTANCE ADJUSTMENT. TO ADJUST, FORKLIFTS MUST BE REMOVED AND ALTERNATE BOLT PATTERN USED ON FORKLIFT TUBE MOUNTING PLATE.

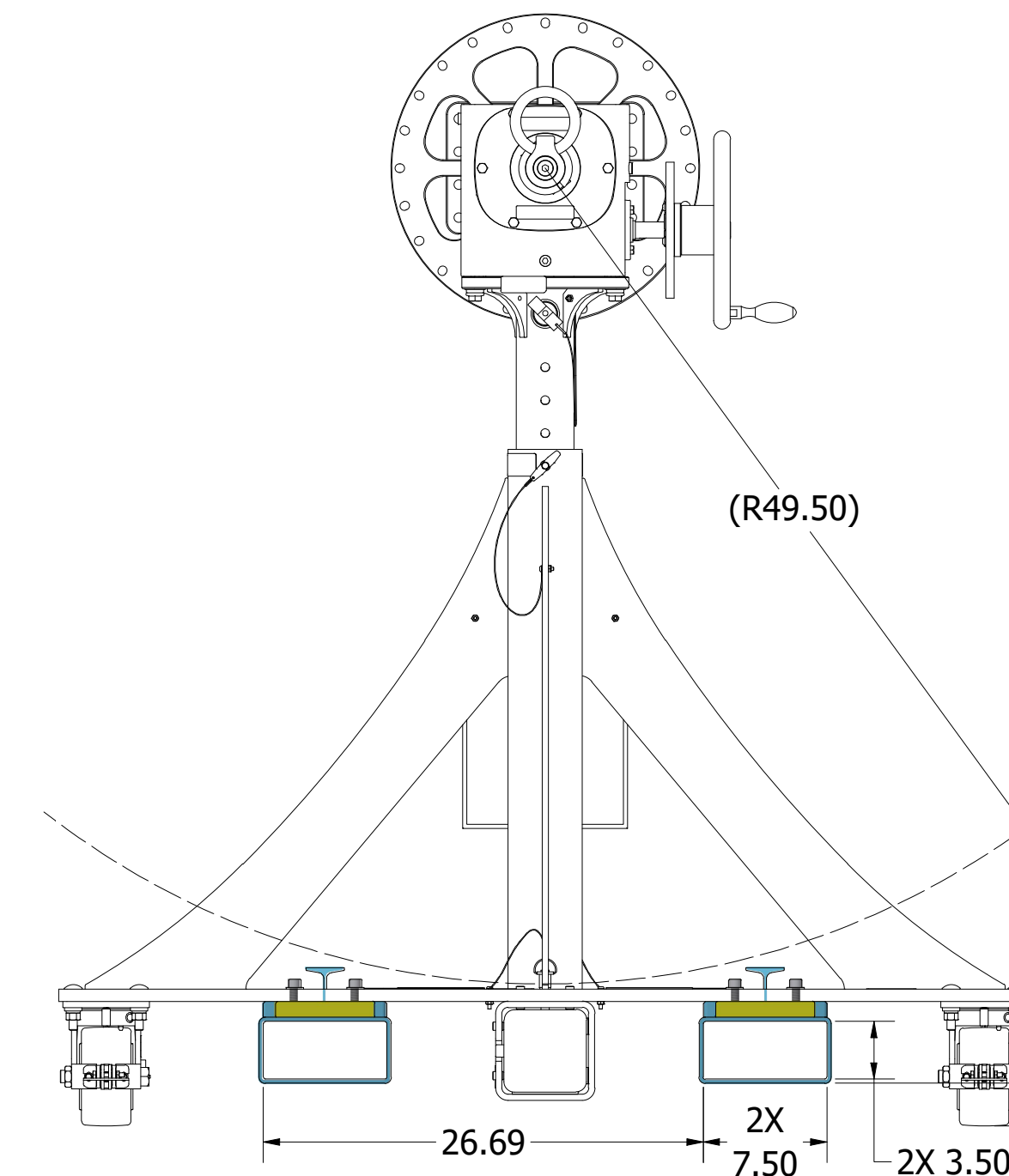

2.60 GROUND CLEARANCE FOR Ø6" STANDARD CASTERS
5.23 GROUND CLEARANCE FOR Ø8" C1 CASTERS

26.69 2X 7.50 2X 3.50

This Drawing is the property of FLOTRON, Inc. and is not to be used, copied or reproduced in any way other than for the particular purpose for which it is provided, and when said purpose has been fulfilled, it should be destroyed or returned to FLOTRON, Inc.

		2630 PROGRESS STREET VISTA, CALIFORNIA 92081 http://www.flotron.com	
		SCALE 1 : 10	SIZE D
		DRAWING NO. 8053-600PROP	REV
		SHEET 5 OF 15	

J5 STABILIZING/LEVELING JACKS

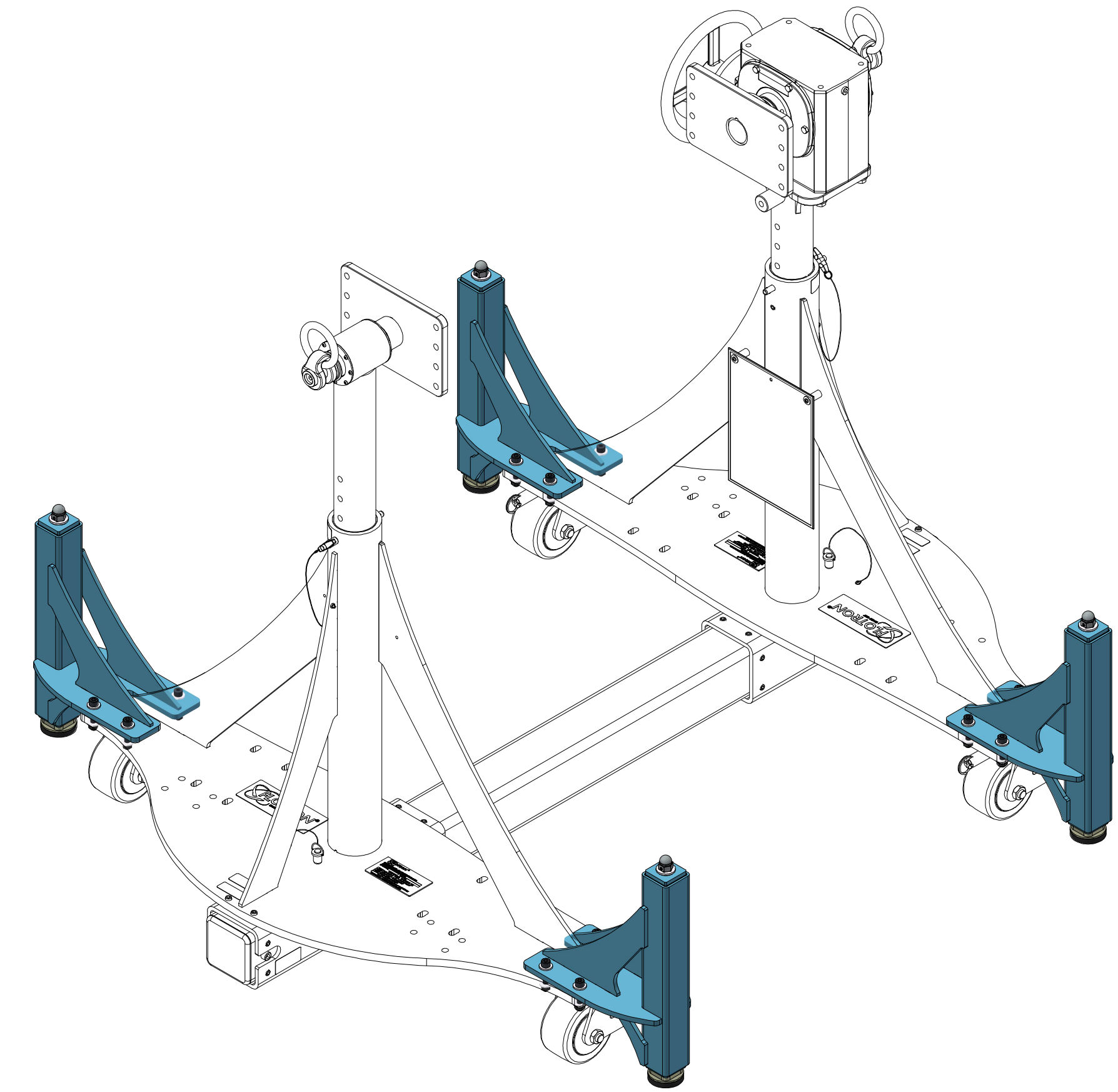
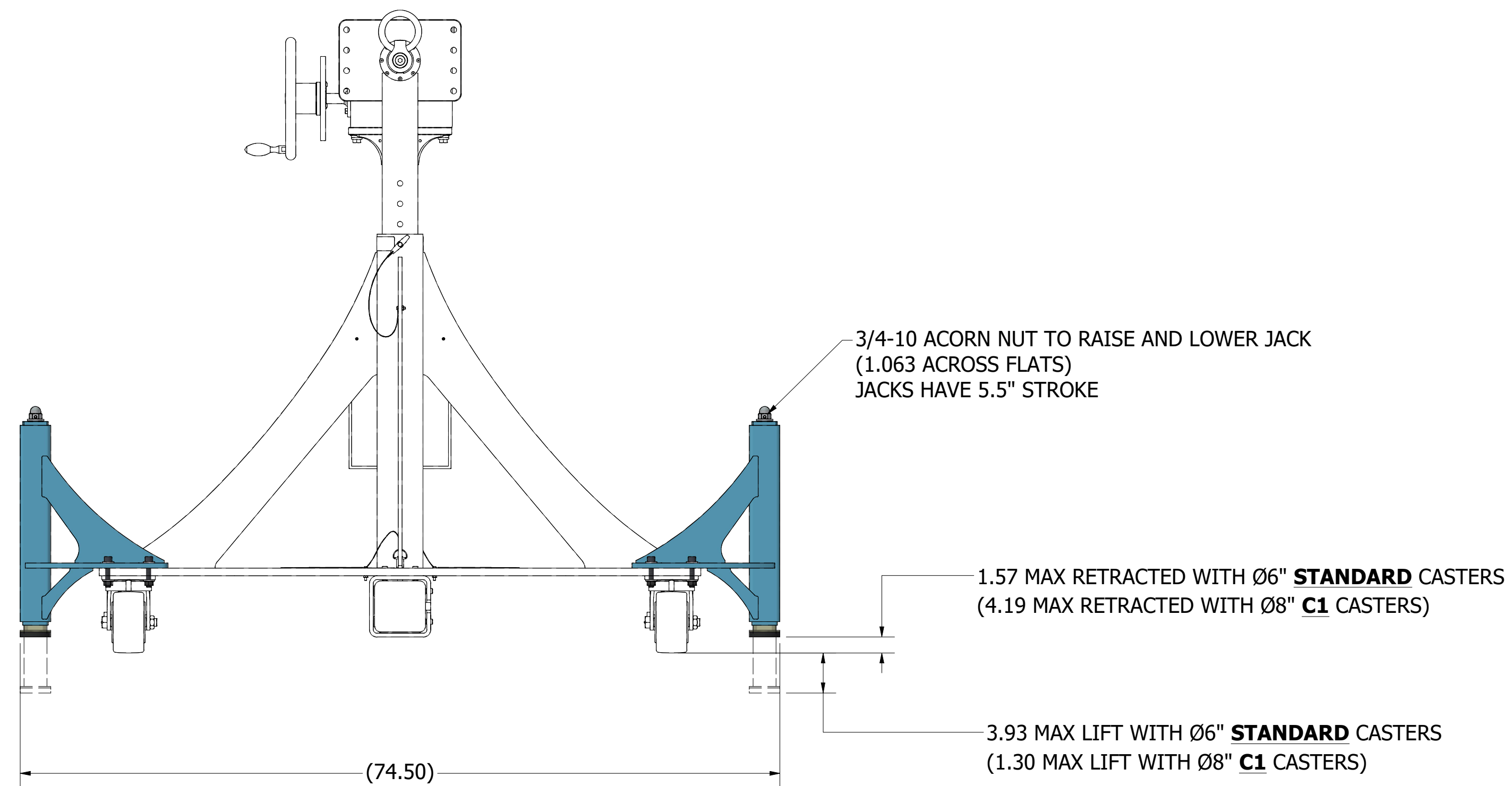

CASTER OPTIONS

STANDARD Ø6" CASTERS WITH SWIVEL LOCK AND BRAKE

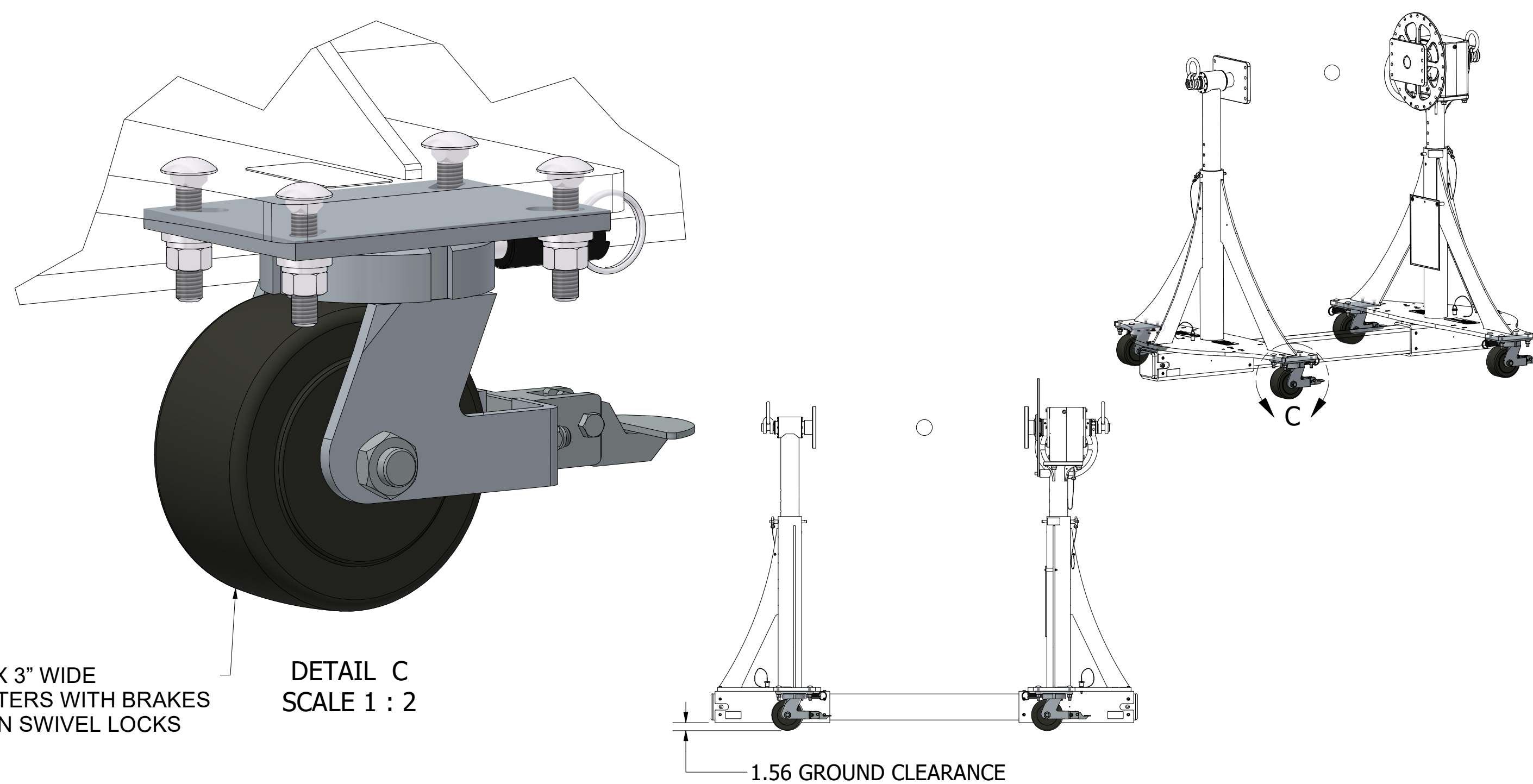

C1 Ø8" CASTERS WITH SWIVEL LOCK AND BRAKE

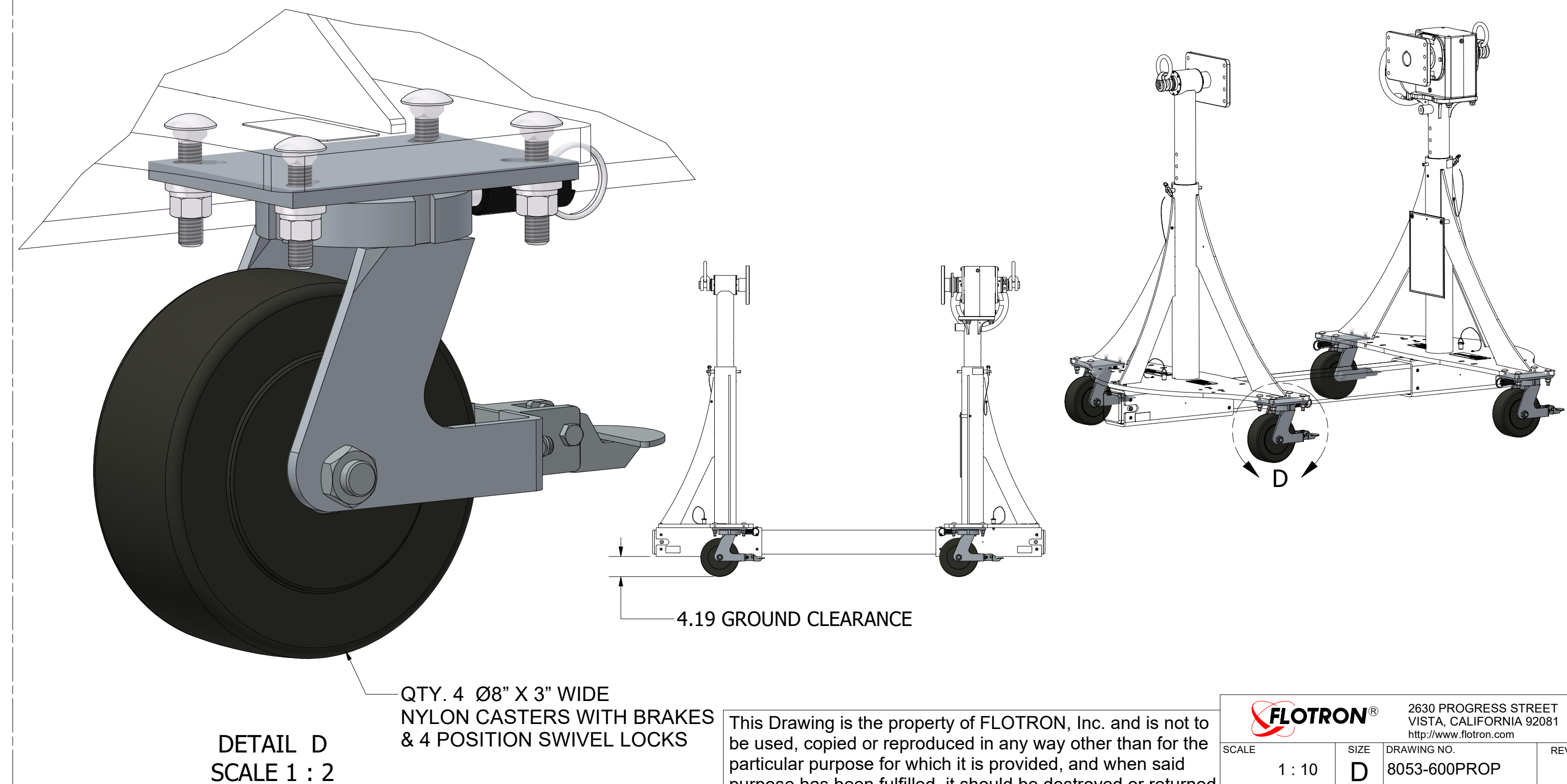

This Drawing is the property of FLOTRON, Inc. and is not to be used, copied or reproduced in any way other than for the particular purpose for which it is provided, and when said purpose has been fulfilled, it should be destroyed or returned to FLOTRON, Inc.

FLOTRON [®]		2630 PROGRESS STREET VISTA, CALIFORNIA 92081 http://www.flotron.com	
SCALE	SIZE	DRAWING NO.	REV
1 : 10	D	8053-600PROP	
SHEET			6 OF 15

D CORDLESS HAND DRILL INPUT

AVAILABLE WITH DR6 OPTION ONLY.

WHEN **D** OPTION IS CHOSEN, DR6 GEARBOX WILL HAVE A 600:1 RATIO.
 DRILL MAX RPM IS 300 RESULTING IN A MAX OUTPUT PAYLOAD ROTATION OF .5 RPM.
 WITH **D** OPTION, FULL GEARBOX TORQUE CAPACITY CAN BE USED.
 COMES STANDARD WITH CLUTCH BETWEEN THE GEARBOX AND HAND CRANK
 TO PREVENT OVER-TORQUE OF GEARBOX IN CASE INDEX PIN WAS
 NOT REMOVED BEFORE ROTATION OR PAYLOAD ECCENTRICITY IS TOO HIGH.
 (SHOWN ABOVE WITH THE IND15 INDEX PLATE AND P12 TRUNNION INTERFACE MOUNT OPTIONS)

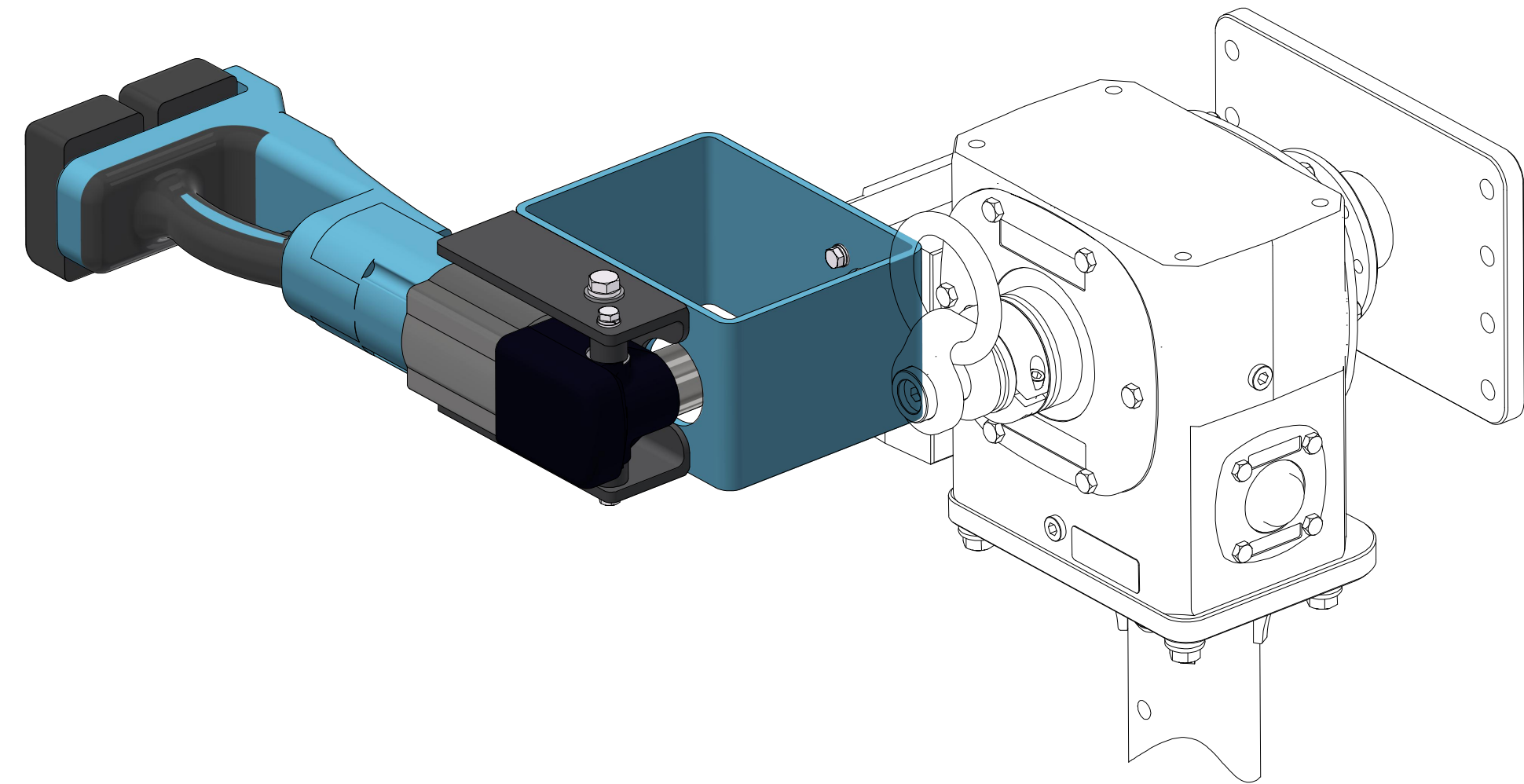

GEARBOX OPTIONS (FOR HAND CRANK)

STANDARD GEARBOX OPTION (60:1)

NON-BACKDRIVING 60:1 RATIO SINGLE STAGE WORM GEAR DRIVE.
 (SHOWN BELOW WITH THE IND15 INDEX PLATE AND P12 TRUNNION INTERFACE MOUNT OPTIONS)

STANDARD GEARBOX TORQUE CAPACITY: 7,500 IN-LBS
STANDARD GEARBOX MAX EASY CRANK TORQUE: 2,000 IN-LBS
 (EASY CRANK IS DEFINED AS A 12 LB INPUT FORCE
 ON THE CRANK HANDLE)

FLYWHEEL COMES STANDARD
 WITH 60:1 RATIO GEARBOX
 TO PREVENT STAIR-STEPPING
 (STICK-SLIP) IN GEARBOX FOR
 HIGH INERTIA PAYLOADS.

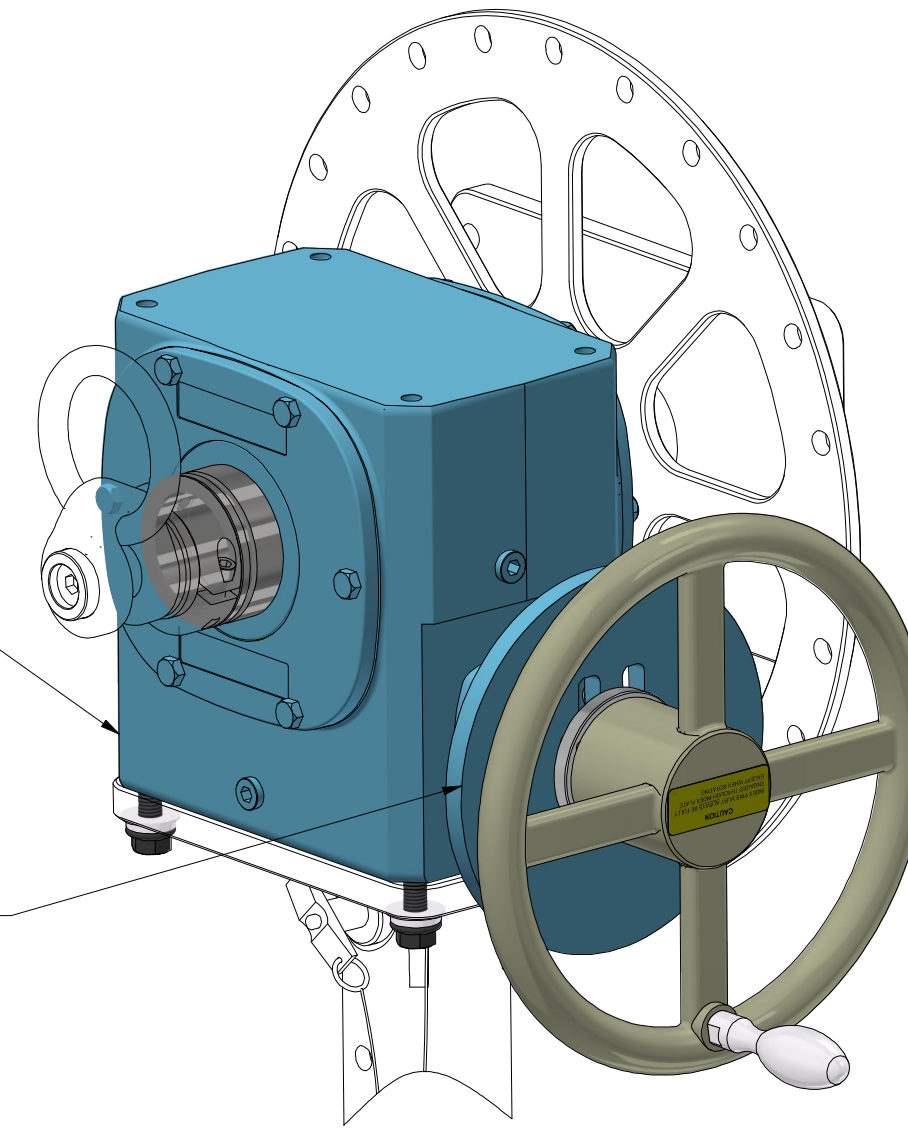

DR3 GEARBOX OPTION (300:1) FOR HIGH ECCENTRICITY HAND CRANK APPLICATION

NON-BACKDRIVING WITH 300:1 RATIO DUAL STAGE WORM GEAR DRIVE.
 (SHOWN BELOW WITH THE IND15 INDEX PLATE AND P12 TRUNNION INTERFACE MOUNT OPTIONS)

DR3 GEARBOX TORQUE CAPACITY: 7,500 IN-LBS
DR3 GEARBOX MAX EASY CRANK TORQUE: 7,200 IN-LBS
 (EASY CRANK IS DEFINED AS A 12 LB INPUT FORCE
 ON THE CRANK HANDLE)

FLYWHEEL COMES STANDARD WITH
 300:1 RATIO GEARBOX TO PREVENT
 STAIN-STEPPING (STICK-SLIP) IN
 GEARBOX FOR HIGH INERTIA PAYLOADS

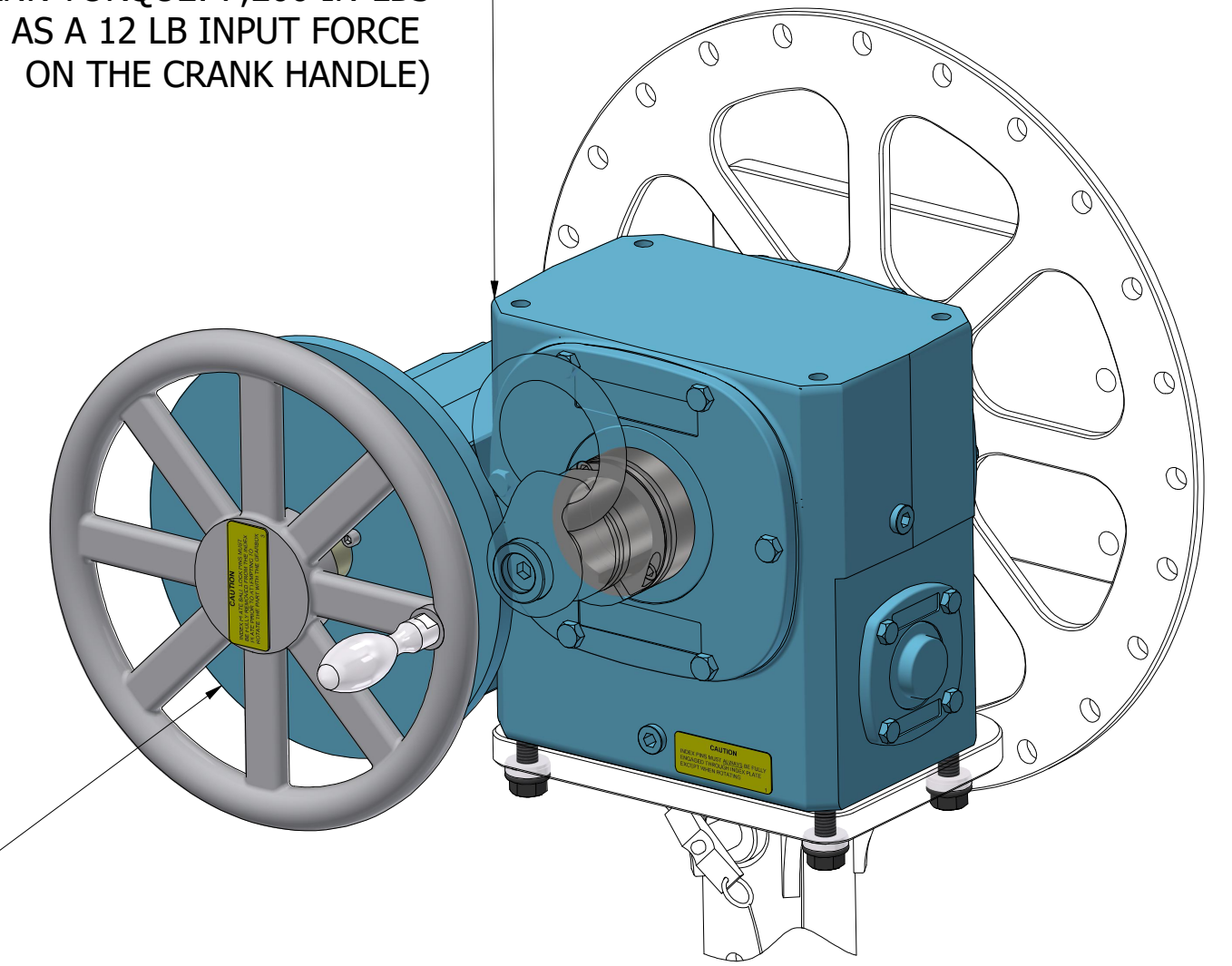

PUSH BAR P1

MOUNTS TO RISER TUBES.
 HEIGHT CAN BE ADJUSTED BY LOOSENING CLAMPING COLLAR.

IF DESIRED, PUSH HANDLE CAN BE MOUNTED ON GEARBOX SIDE RISER
 BUT WILL ONLY WORK WHEN RISER IS IN TOP TWO PIN POSITIONS.
 (RISER SHOWN FULLY LOWERED IN THIS VIEW)

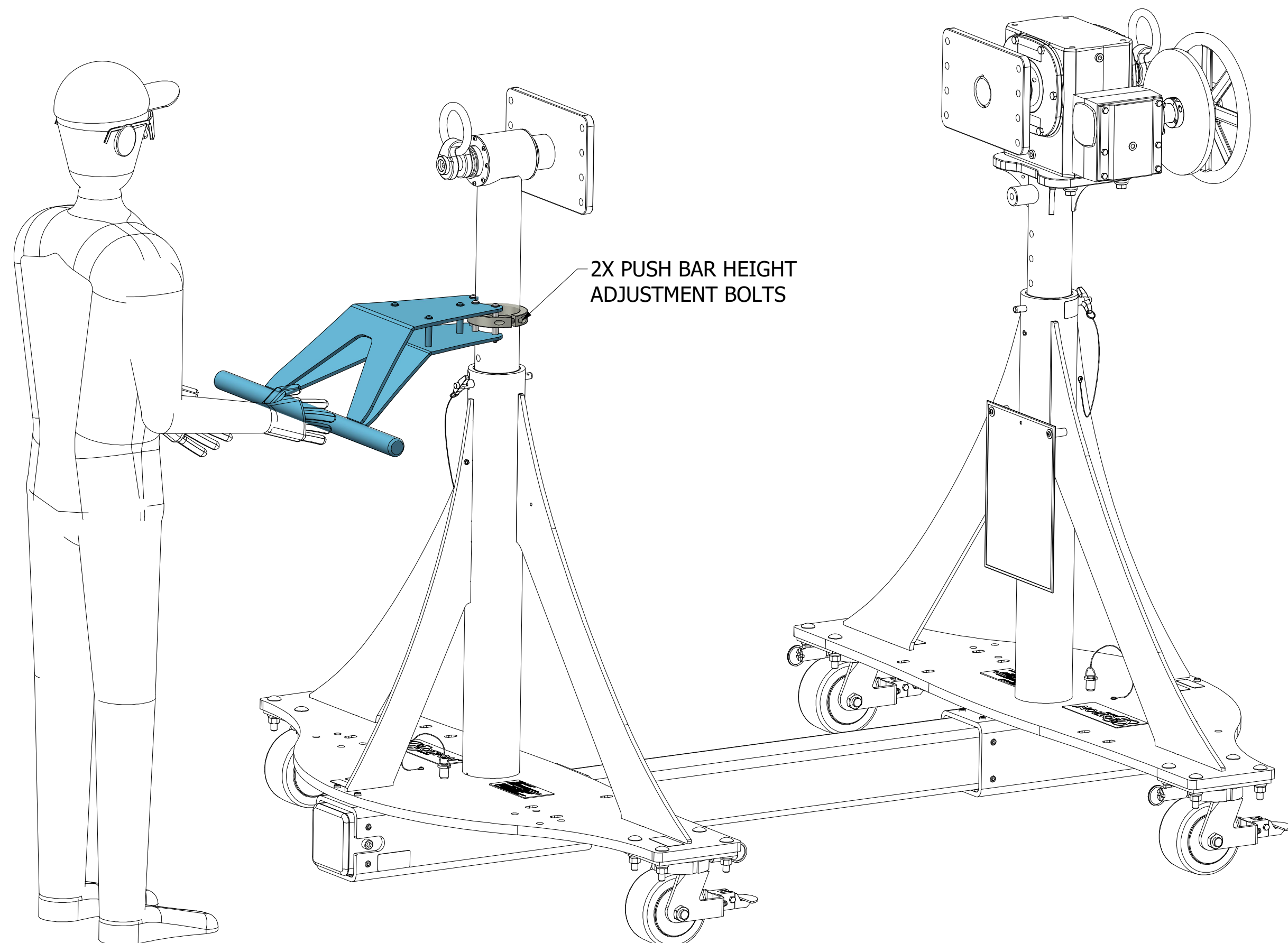

42.67 MAX WITH STANDARD CASTER SHOWN
 (45.27 MAX WITH Ø8" C1 CASTER)
 (CAN GO HIGHER THAN THESE NUMBERS AT
 HIGHER RISER PIN HEIGHTS)

36.92 MIN WITH STANDARD CASTER
 (39.55) MIN WITH Ø8" **C1** CASTER

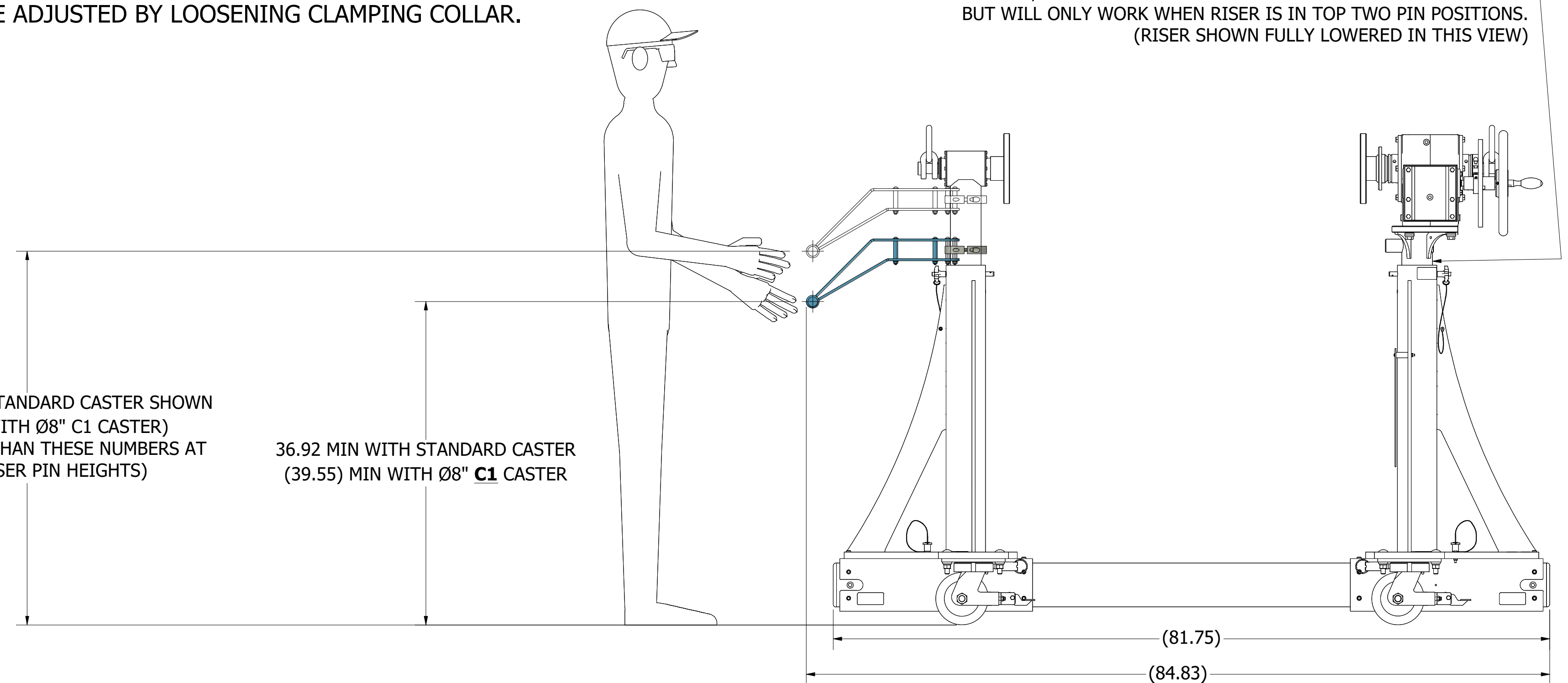

This Drawing is the property of FLOTRON, Inc. and is not to be used, copied or reproduced in any way other than for the particular purpose for which it is provided, and when said purpose has been fulfilled, it should be destroyed or returned to FLOTRON, Inc.

TRUNNION INTERFACE MOUNT OPTIONS

P12 PAYLOAD INTERFACE (TYPICAL BOTH SIDES)

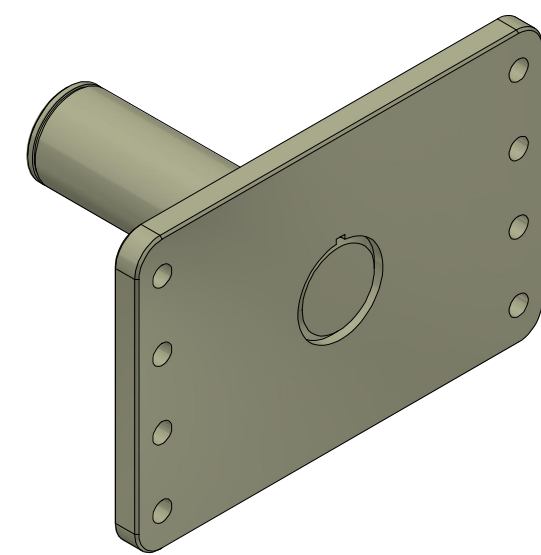
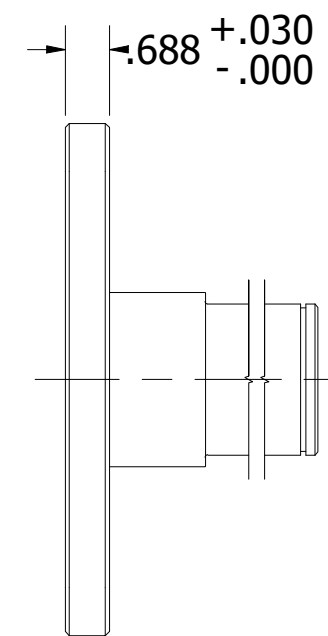
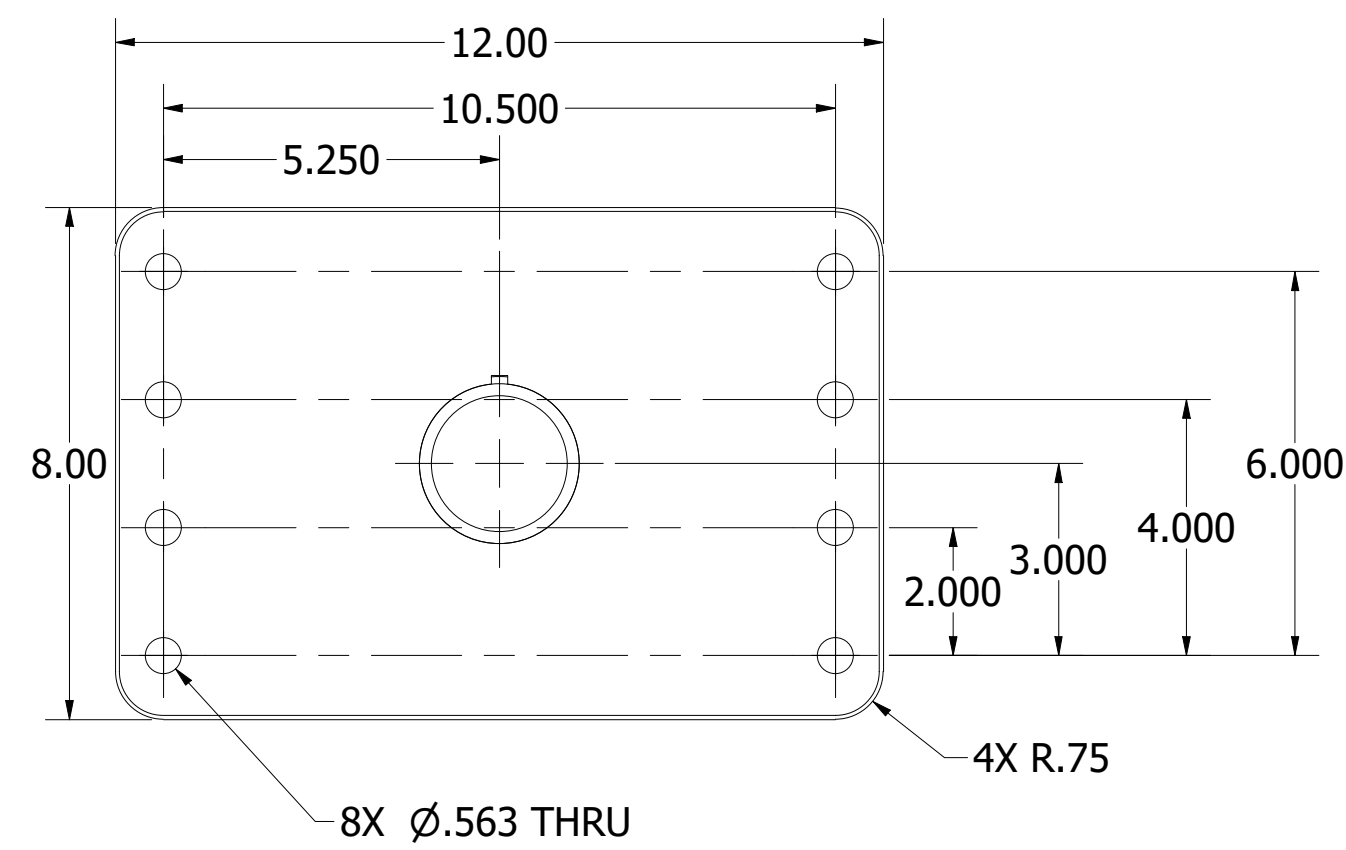

P12/B30 PAYLOAD INTERFACE (WITH STANDARD BOLT HOLE PATTERN AND MACHINED MOUNTING SURFACE) (TYPICAL BOTH SIDES)

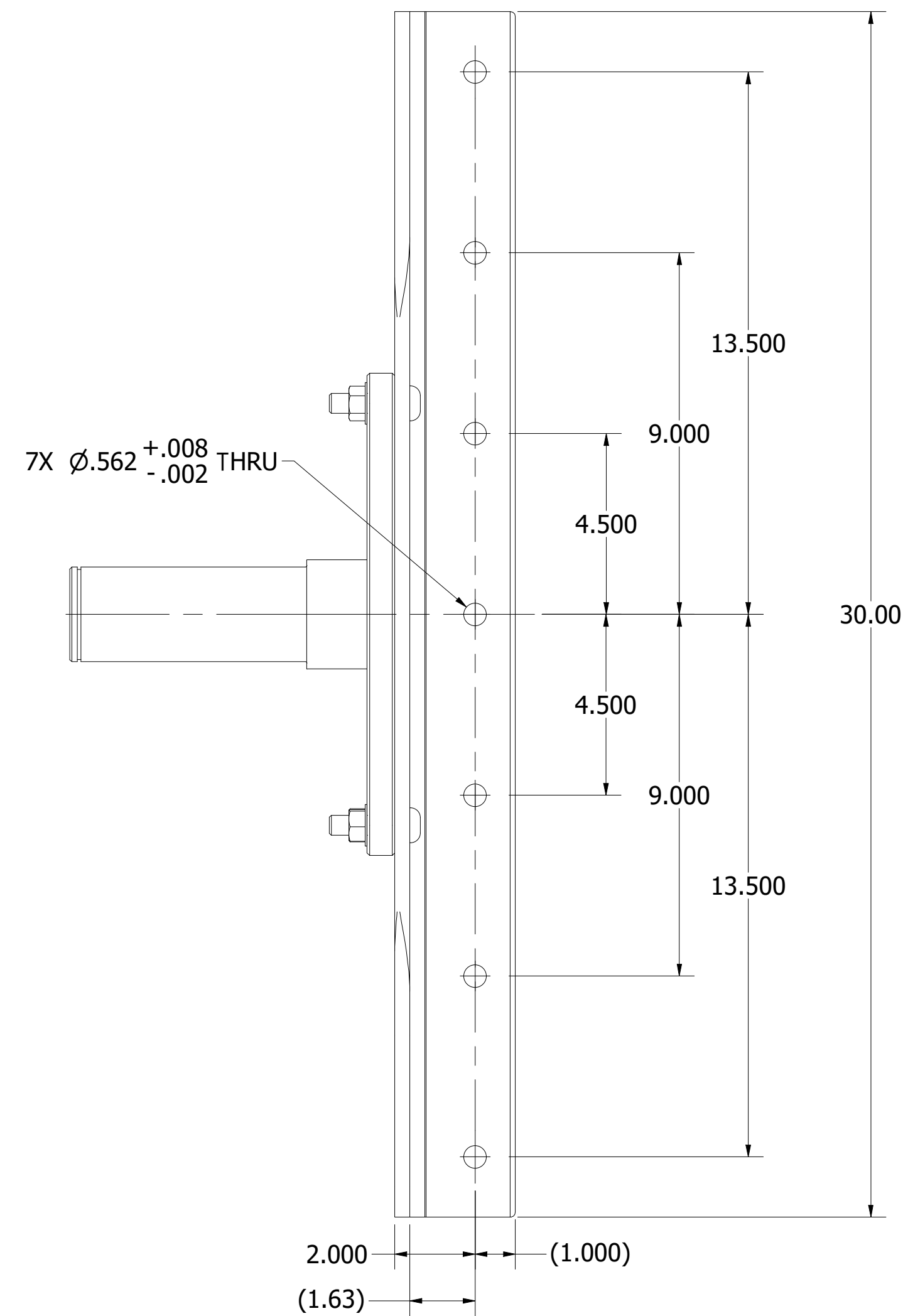

WHEN P12/B30 OPTION IS CHOSEN, "B" DISTANCE IS MEASURED FROM THIS FACE (NOT FROM HOLE PATTERN)

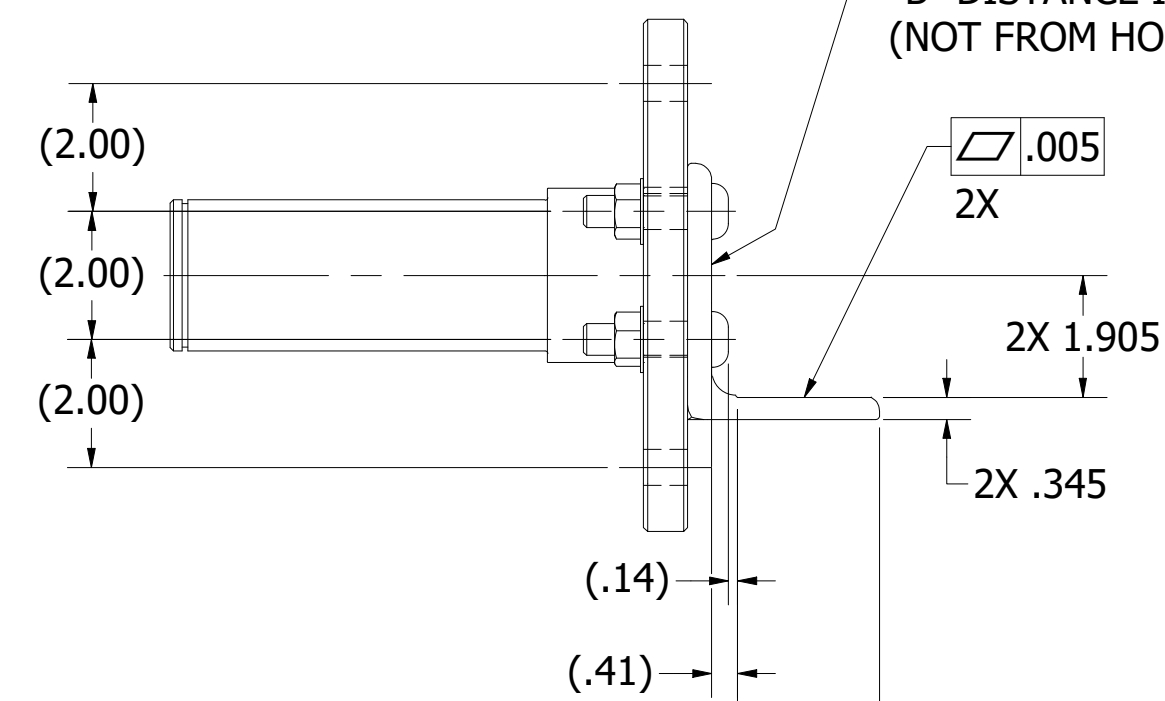

2X
2.220 MOUNT SURFACE

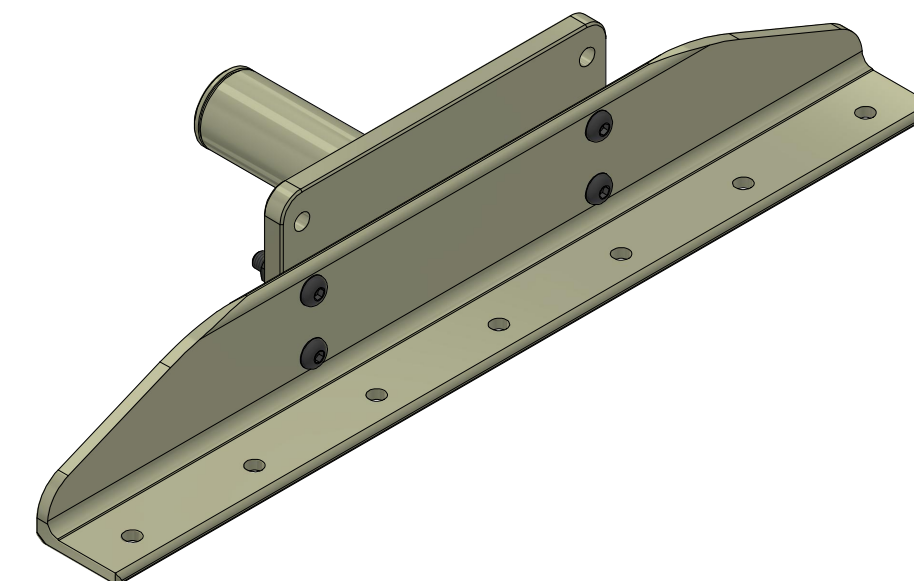

P12/A30 PAYLOAD INTERFACE (WITH MACHINED MOUNTING SURFACE & NO PRE-MACHINED HOLE PATTERN) (TYPICAL BOTH SIDES) (OTHER NON-STANDARD LENGTH ANGLES AVAILABLE UPON REQUEST)

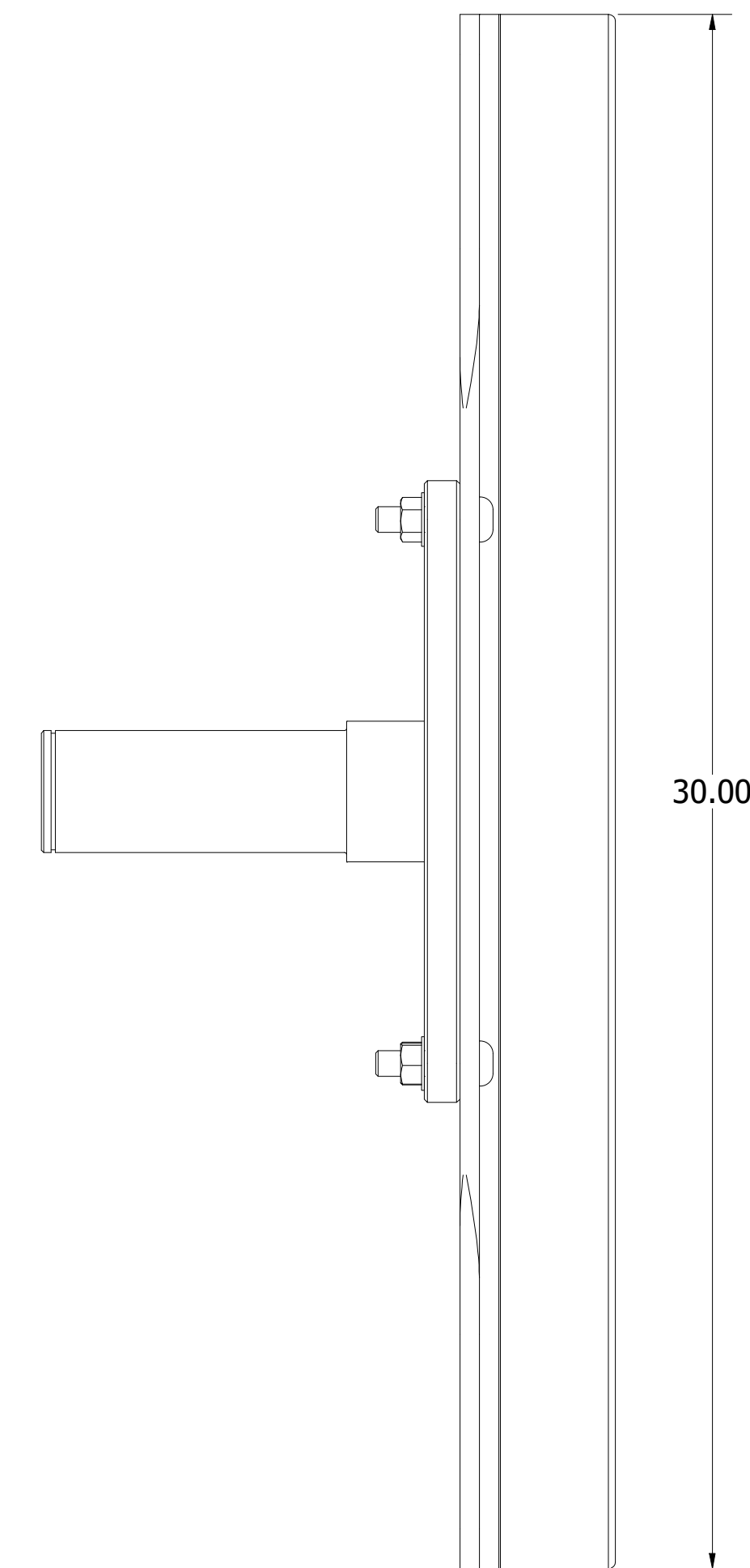

WHEN P12/A30 OPTION IS CHOSEN, "B" DISTANCE IS MEASURED FROM THIS FACE

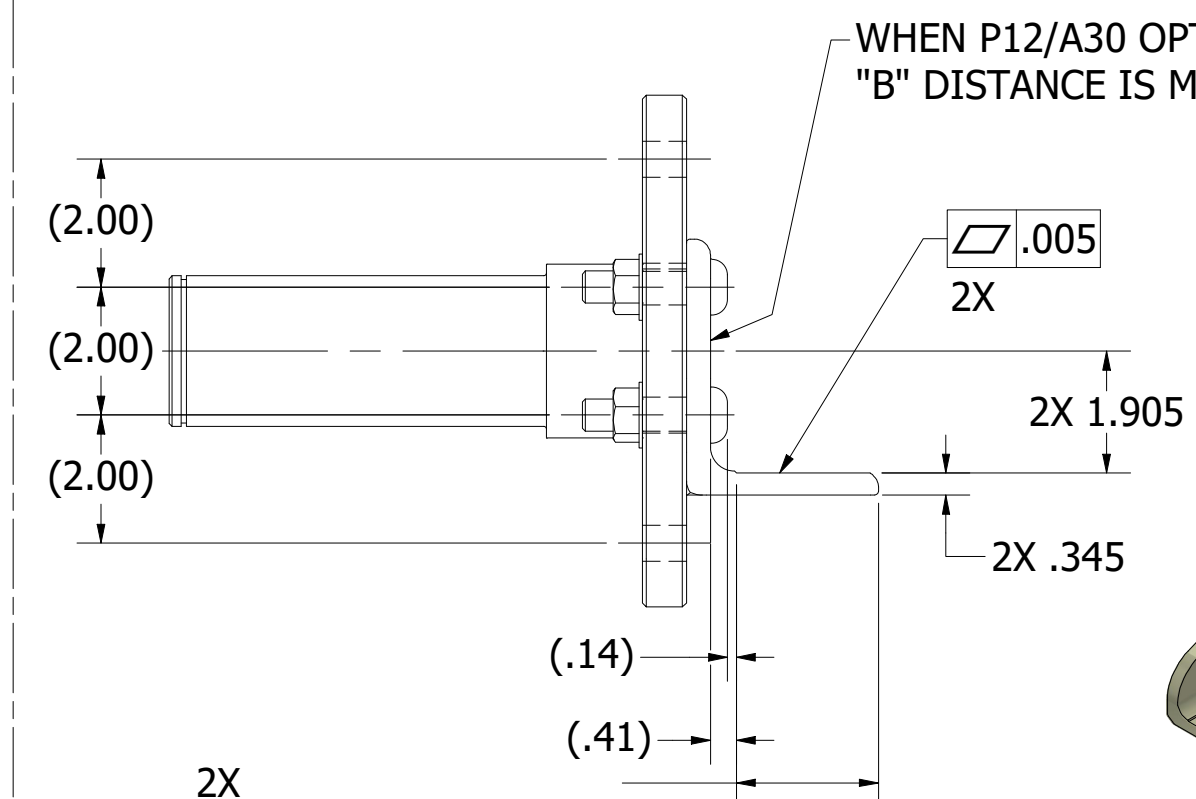

2X
2.220 MOUNT SURFACE

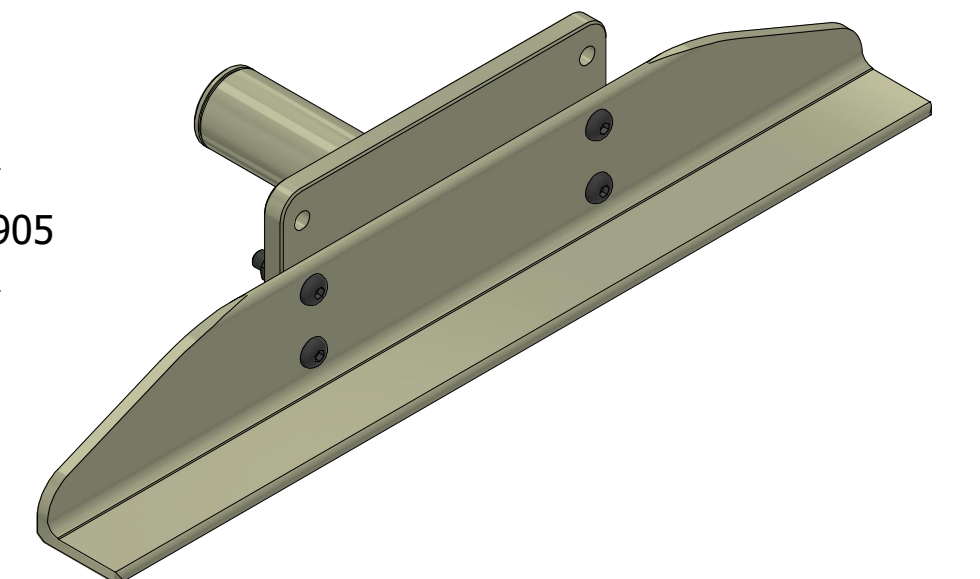

This Drawing is the property of FLOTRON, Inc. and is not to be used, copied or reproduced in any way other than for the particular purpose for which it is provided, and when said purpose has been fulfilled, it should be destroyed or returned to FLOTRON, Inc.

		2630 PROGRESS STREET VISTA, CALIFORNIA 92081 http://www.flotron.com	
SCALE	SIZE	DRAWING NO.	REV
1 : 10	D	8053-600PROP	
SHEET			8 OF 15

TOW HARDWARE OPTIONS

T1 REMOVEABLE TOW RING INSERT

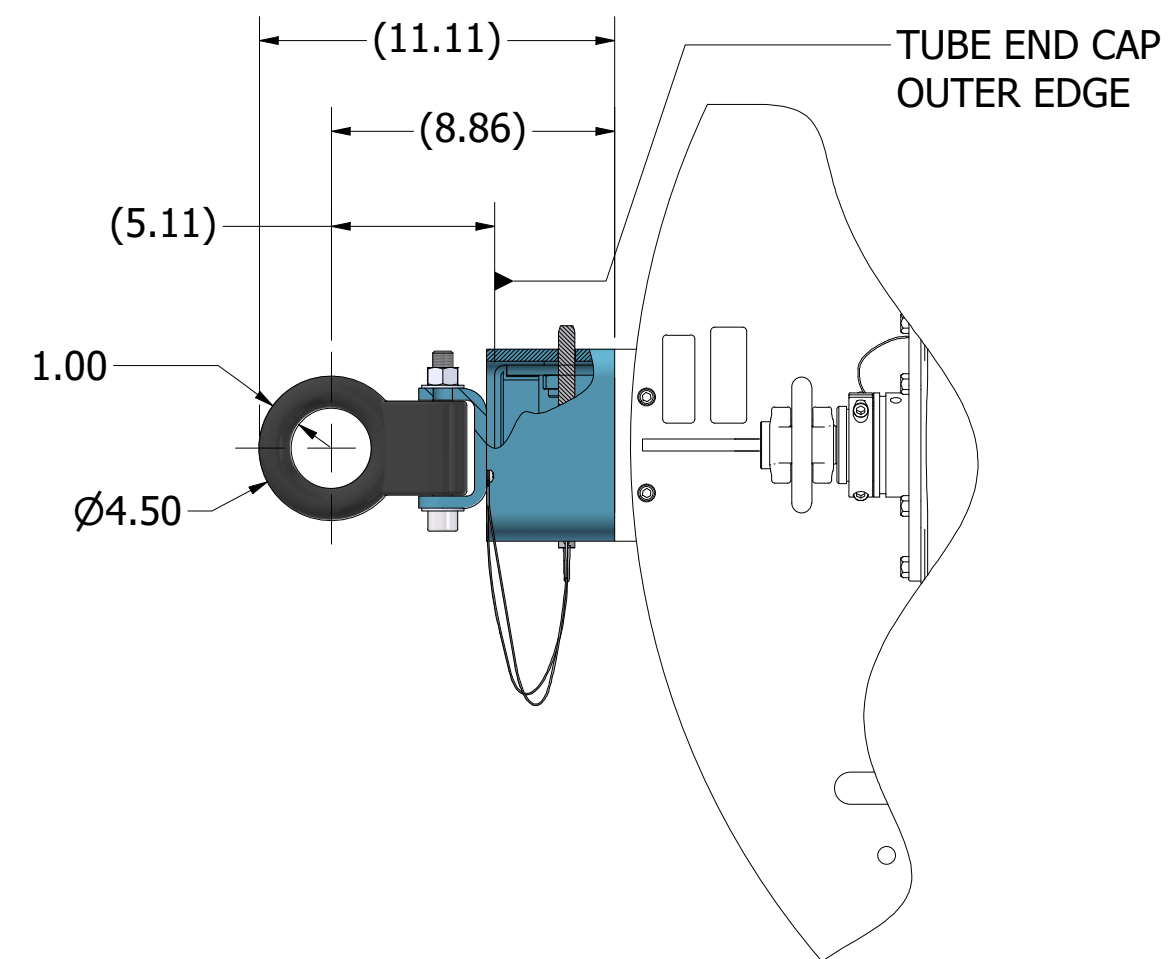
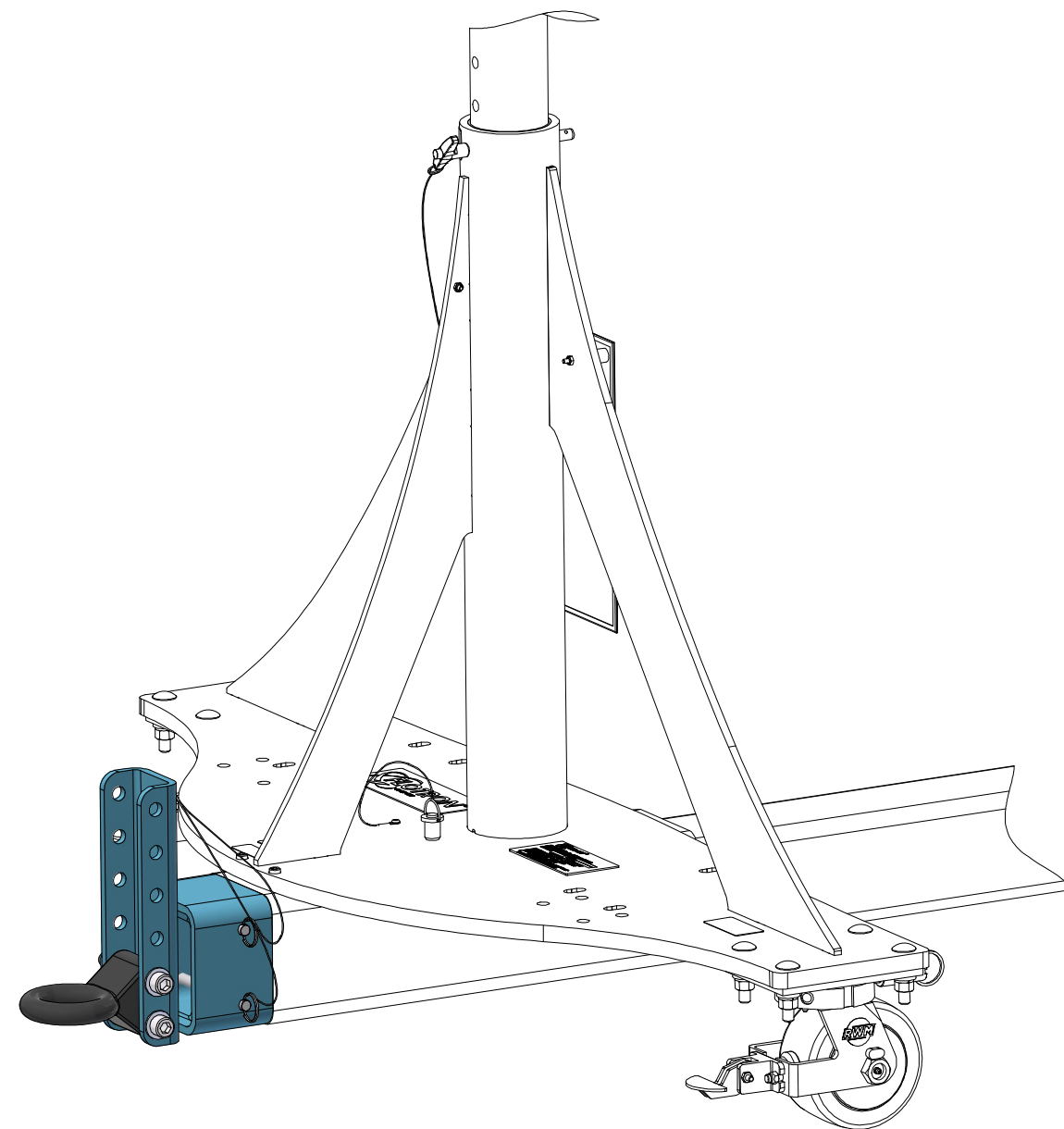

3.19 MIN SHOWN (STANDARD Ø6" CASTERS)
TO
11.19 MAX (STANDARD Ø6" CASTERS)
5.82 MIN (Ø8" C1 CASTERS)
TO
13.82 MAX (Ø8" C1 CASTERS)

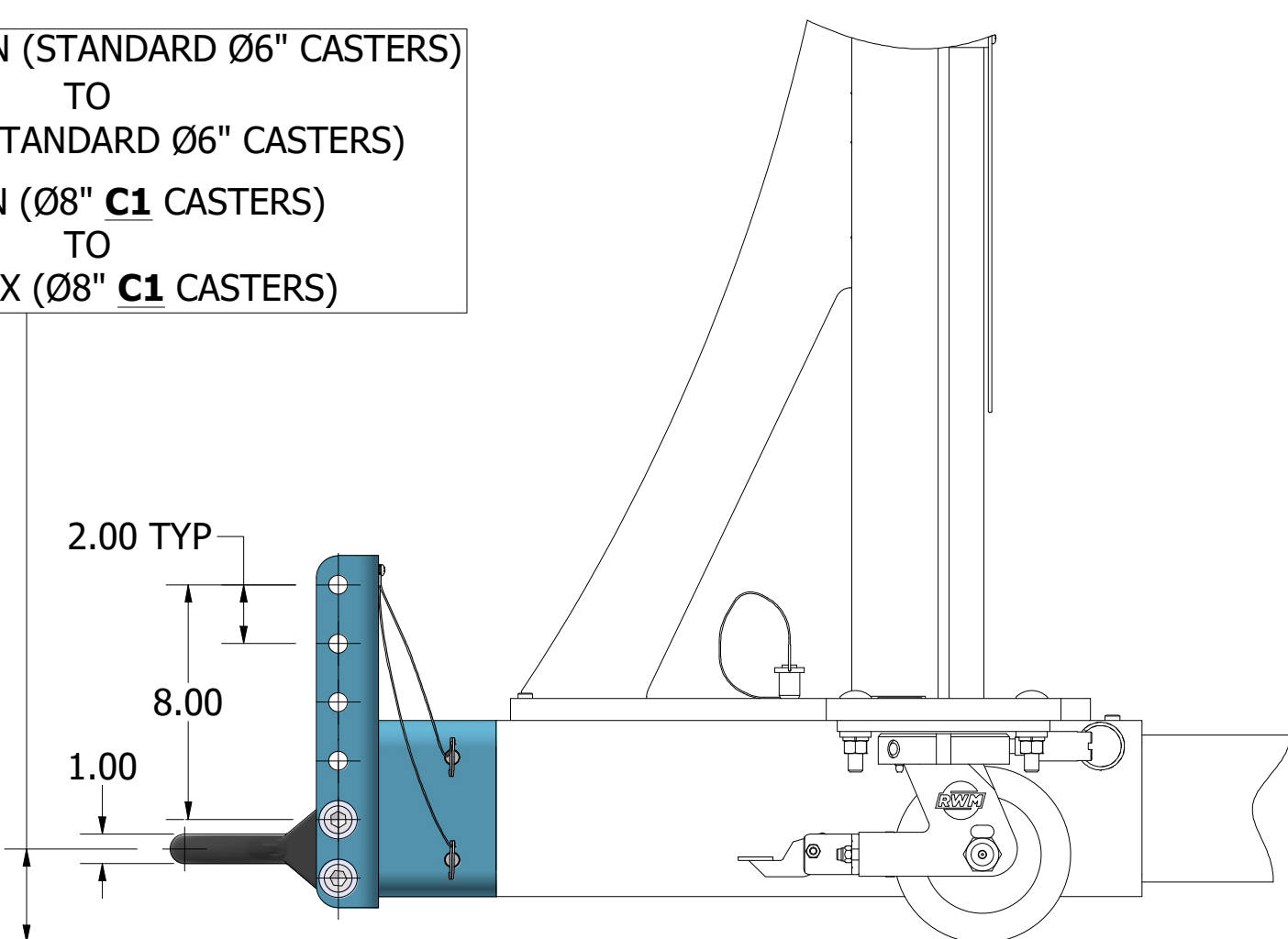

T2 REMOVEABLE TOW BALL INSERT

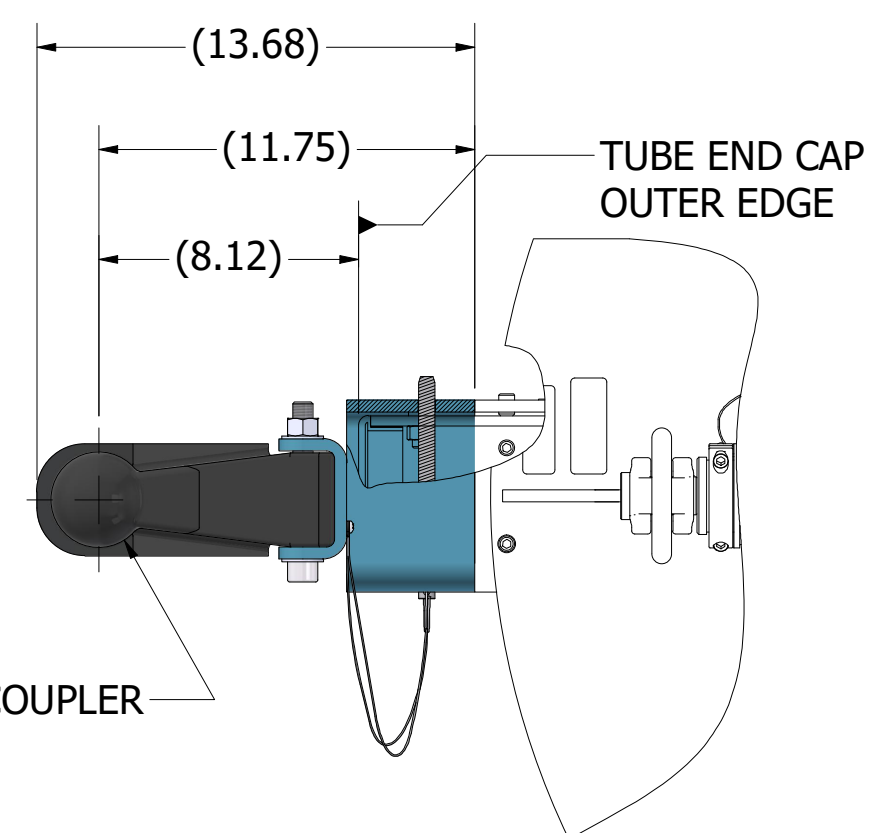
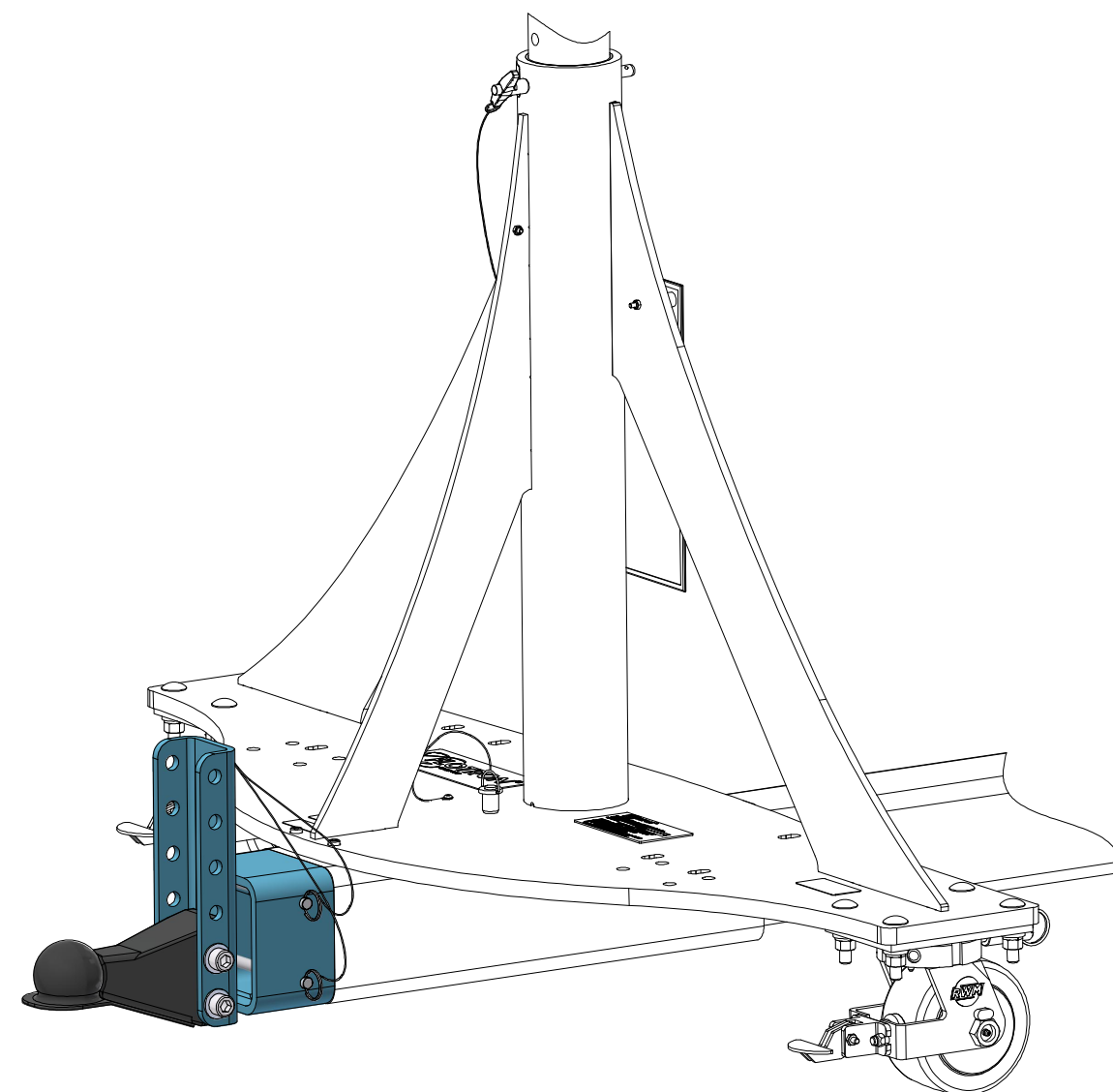

3.94 MIN SHOWN (STANDARD Ø6" CASTERS)
TO
11.94 MAX (STANDARD Ø6" CASTERS)
6.57 MIN (Ø8" C1 CASTERS)
TO
14.57 MAX (Ø8" C1 CASTERS)

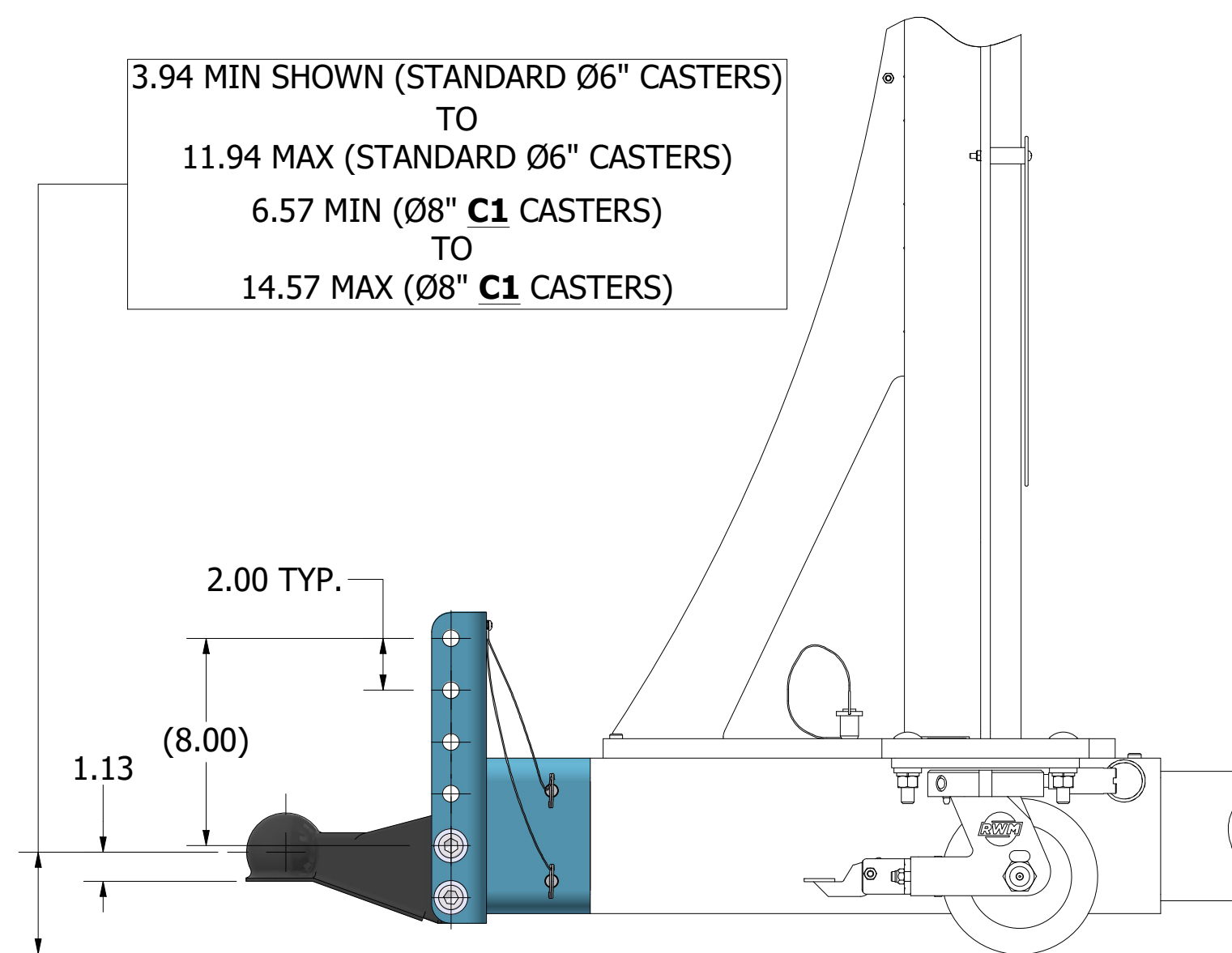

T3 REMOVEABLE TOW BAR

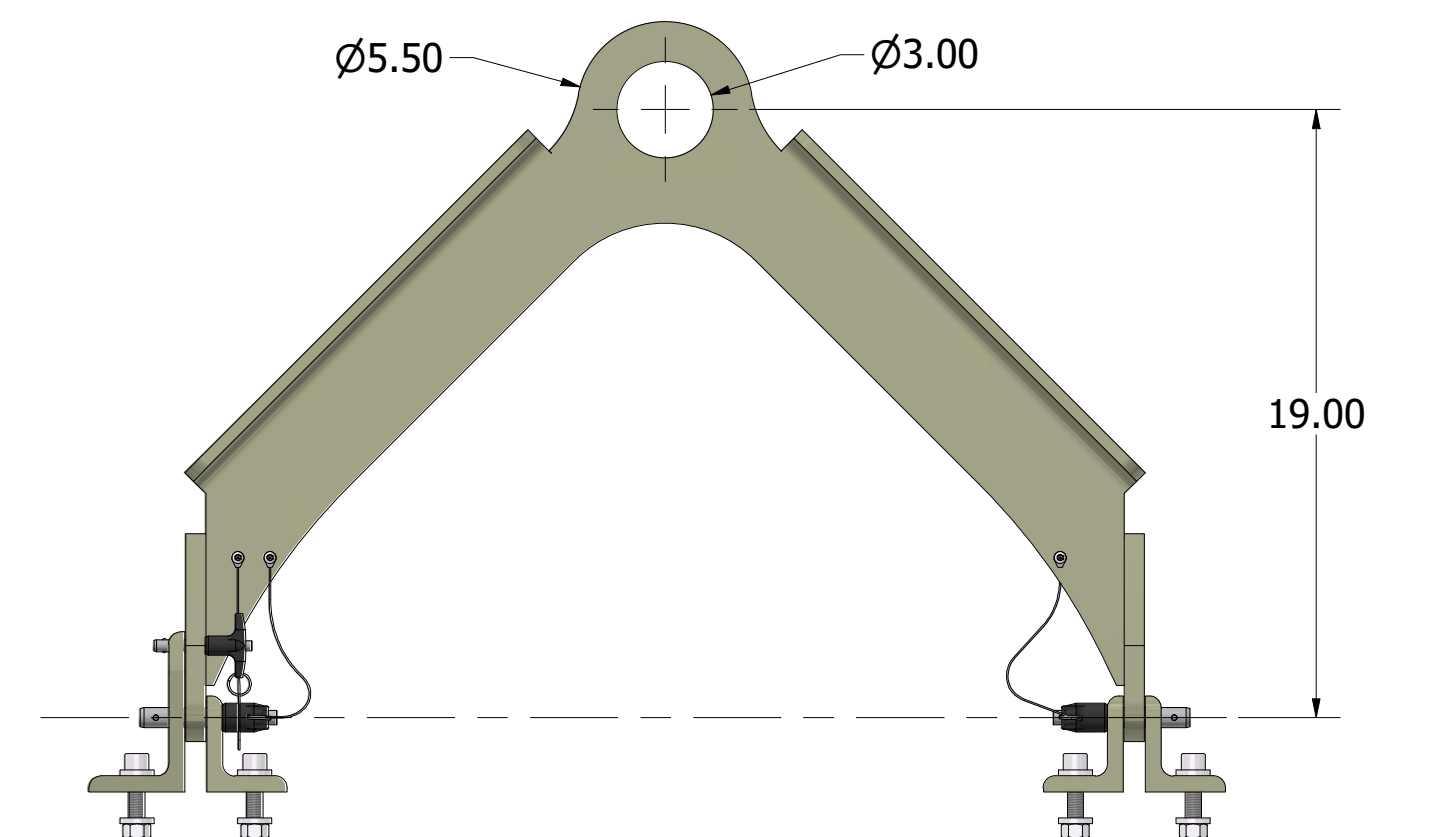
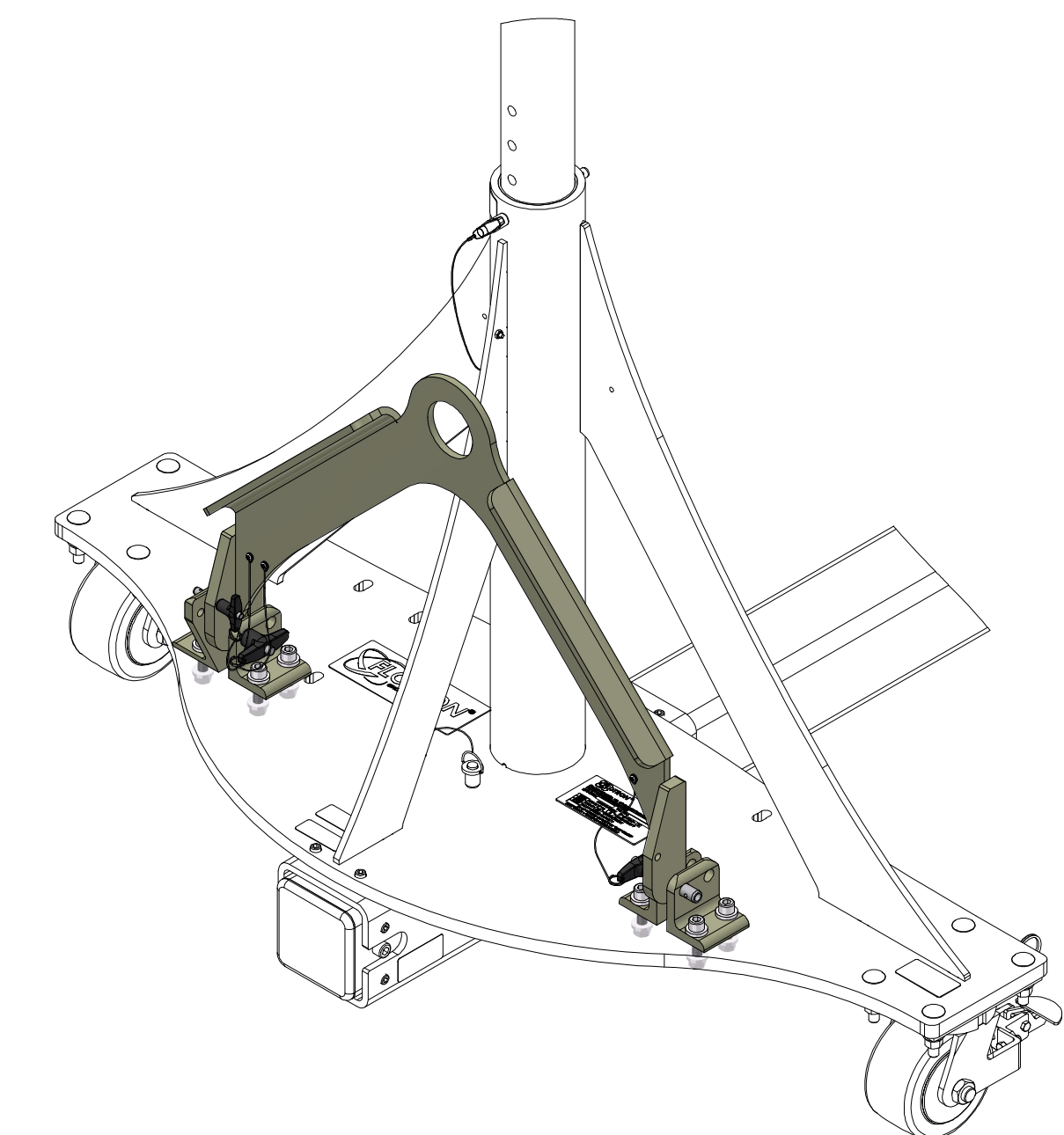

10.63 FOR STANDARD Ø6" CASTERS
13.26 FOR Ø8" C1 CASTERS

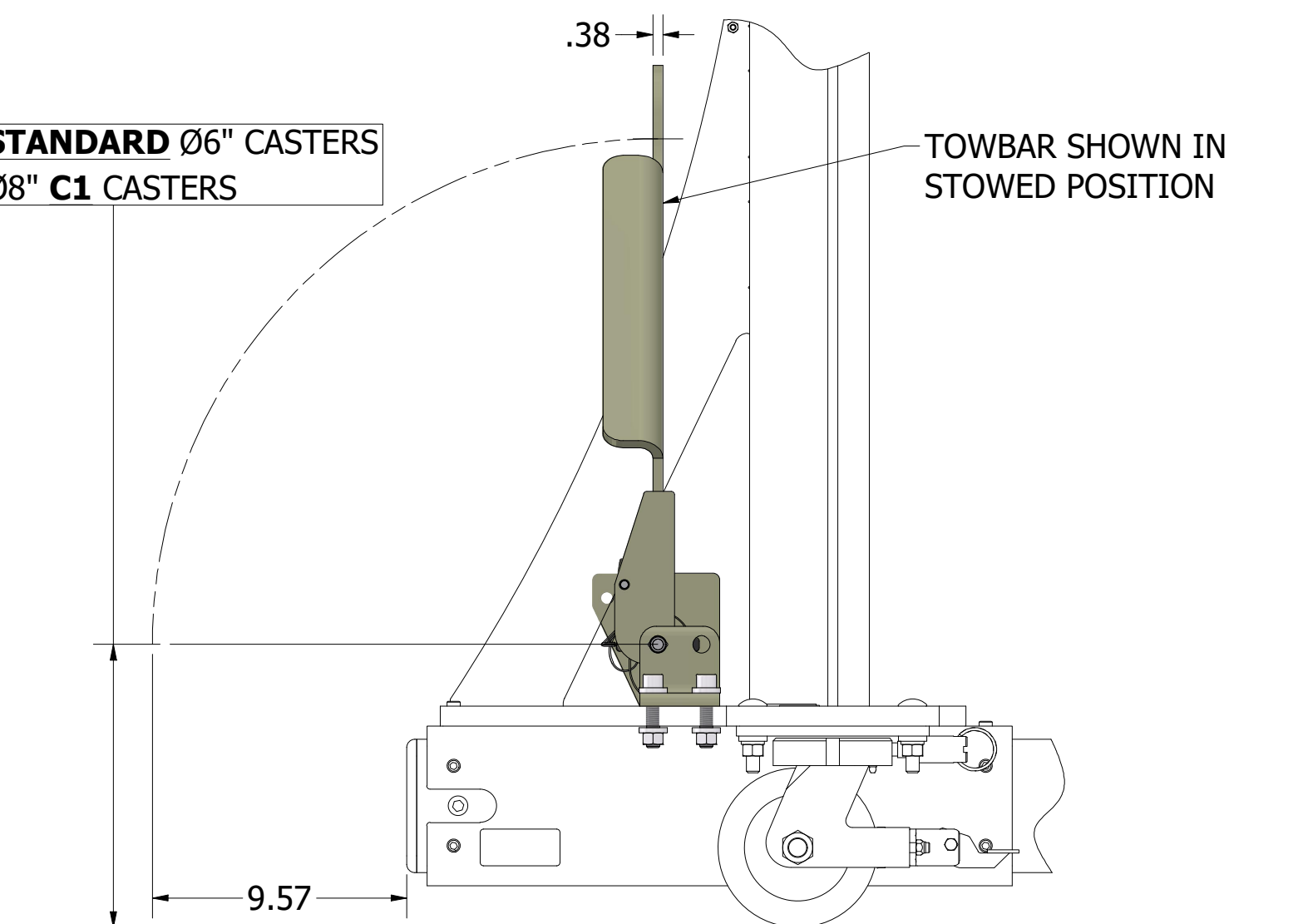

This Drawing is the property of FLOTRON, Inc. and is not to be used, copied or reproduced in any way other than for the particular purpose for which it is provided, and when said purpose has been fulfilled, it should be destroyed or returned to FLOTRON, Inc.

SECONDARY AXIS OF ROTATION CRADLE (SA1-SA8)

BOLT POSITIONS CAN BE CHANGED IN THE FIELD, BUT BOLT POSITION SELECTED WILL BE THE BOLT POSITION THE FIXTURE IS SHIPPED WITH. WITH SA OPTION, FIXTURE CAPACITY IS REDUCED TO 1,800 LBS CANTILEVERED 33.75" MAX FROM INTERFACE. SEE LOAD CHARTS ON SHEETS 11-14 TO SELECT BEST BOLT POSITION FOR YOUR APPLICATION. MUST SELECT B120 INTERFACE DISTANCE WHEN SPECIFYING STANDARD LENGTH CRADLE. SPECIAL LENGTH CRADLES AVAILABLE UPON REQUEST IN INCREMENTS OF 20". SEE SALES FOR MORE INFORMATION. TO GET MOST CAPABILITY OUT OF SA OPTION AND FOR BEST OPERATOR EXPERIENCE, "DR6" GEARBOX WITH DRILL DRIVE INPUT ("D" OPTION) IS HIGHLY RECOMMENDED.

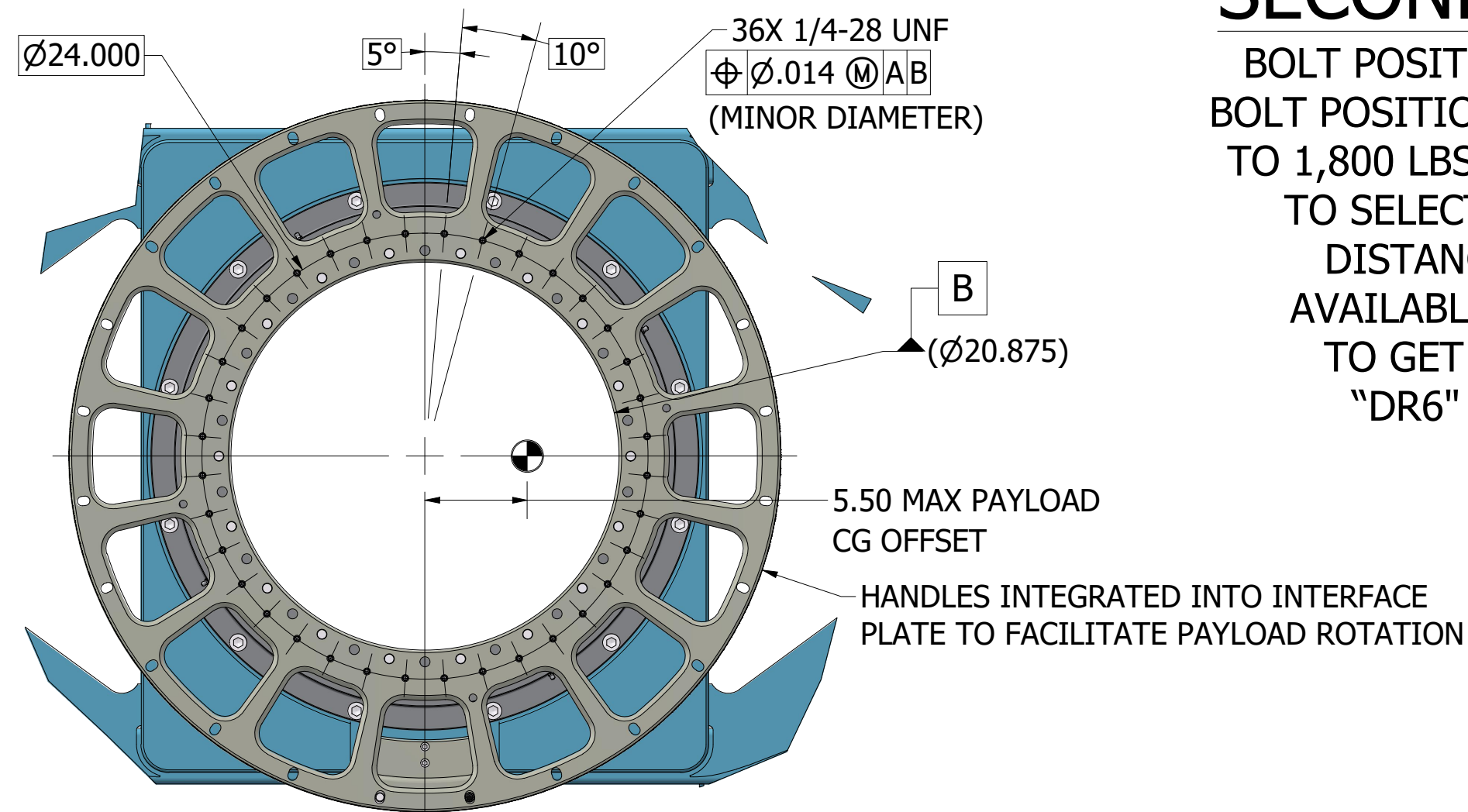

DETAIL M
SCALE 1 : 8
INTERFACE HOLE PATTERN
(STANDARD 24" ESPA GRANDE HOLE PATTERN)

CRADLE LIFT POINTS TO BE USED FOR BOLT POSITION ADJUSTMENT. MINIMUM 45° SLING ANGLE REQ'D.

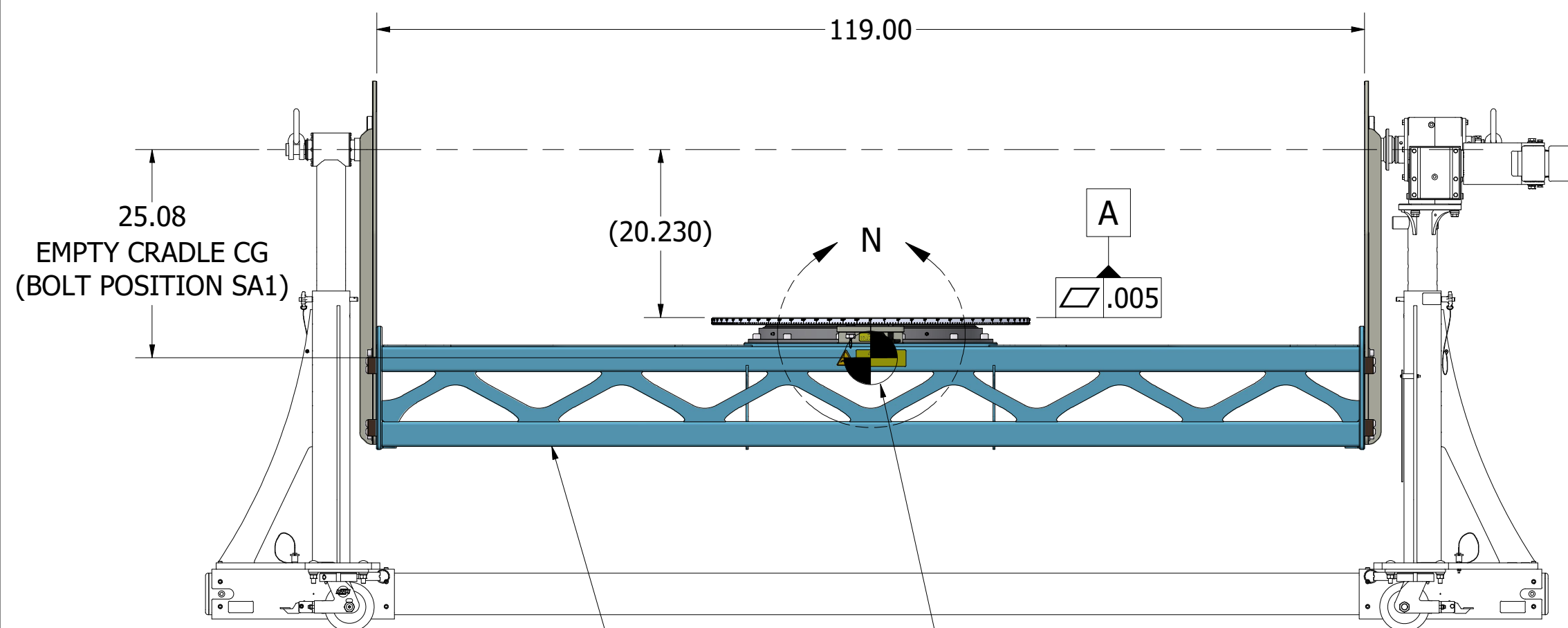
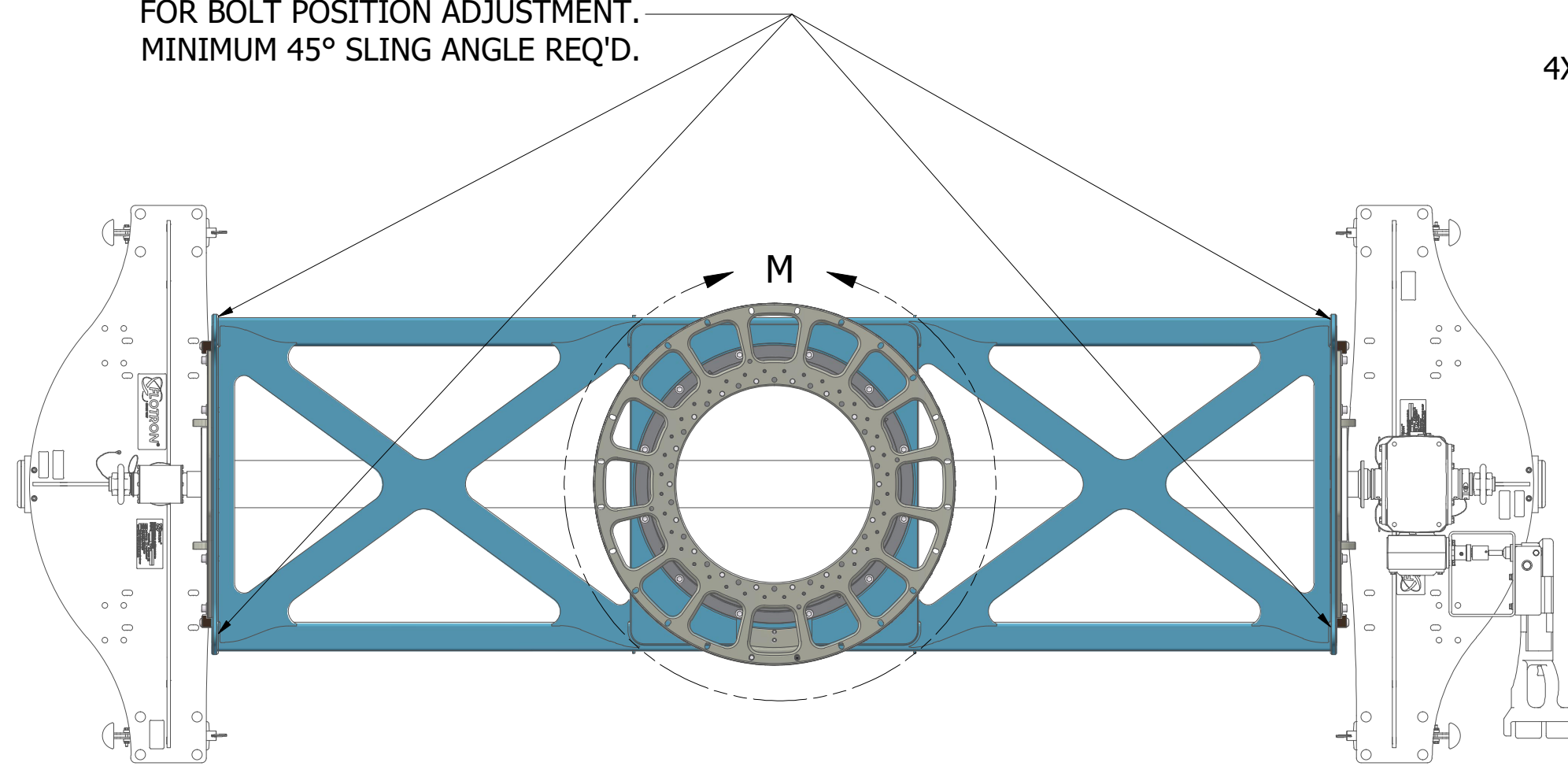

UNLOADED CRADLE COG @ BOLT POSITION 1
APPROXIMATE EMPTY CRADLE WEIGHT: 665 LBS

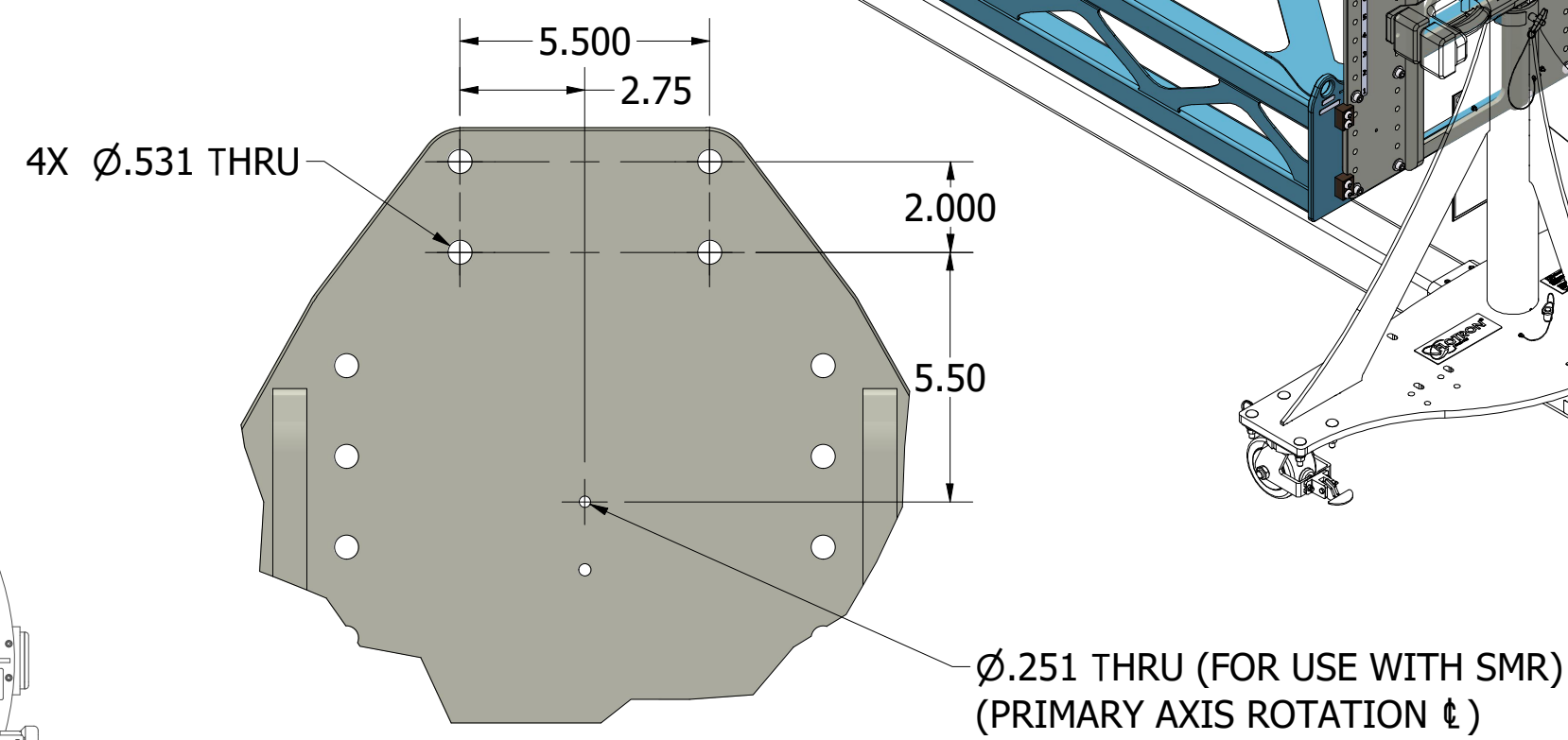
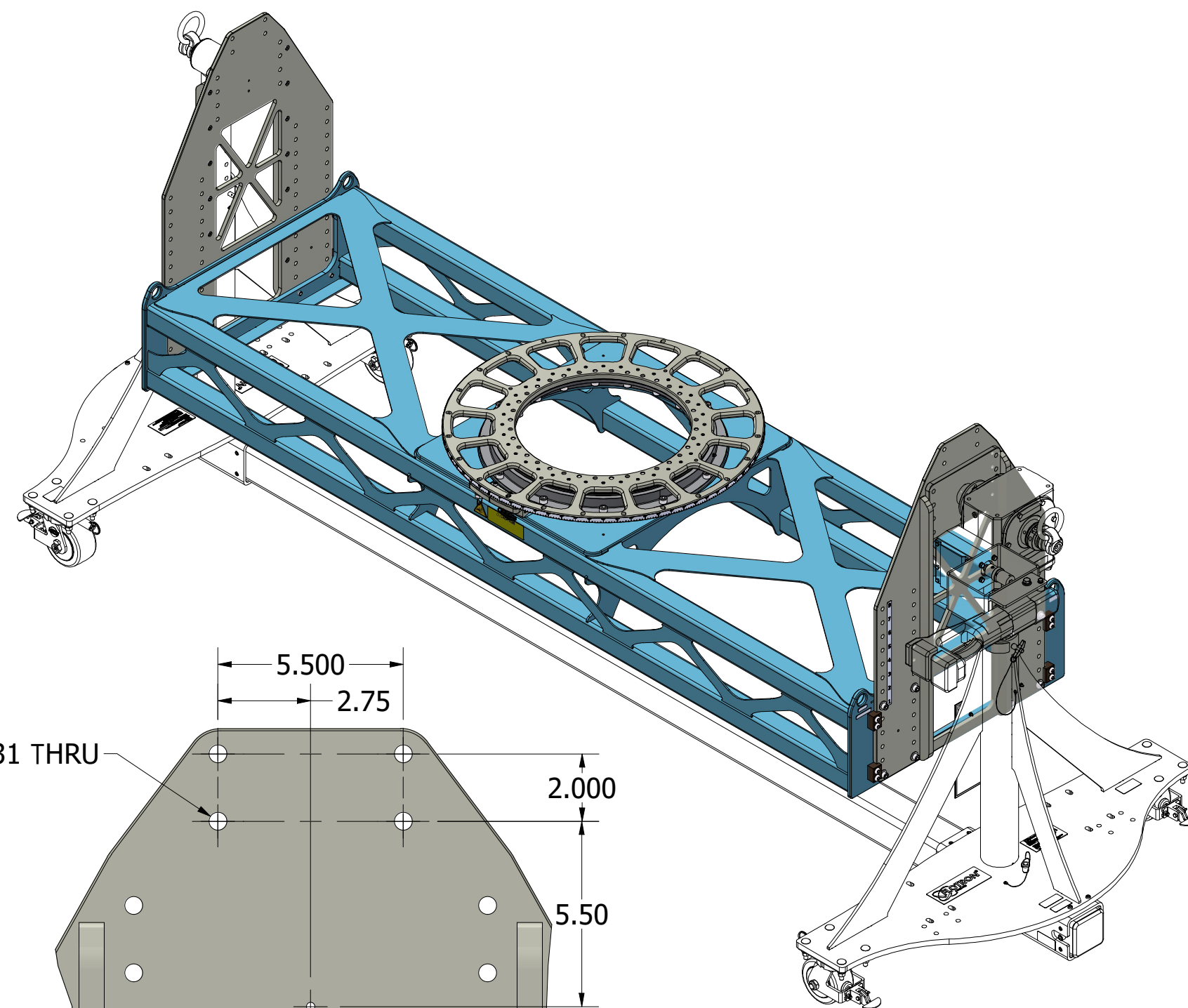

DETAIL R
SCALE 1 : 4
HOLE PATTERN FOR ATTACHING COUNTERWEIGHT (IF REQ'D)

8X BOLTS PER SIDE TO BE REMOVED FOR BOLT POSITION ADJUSTMENT. CENTRAL CRADLE MUST BE SUPPORTED BY OVERHEAD CRANE PRIOR TO BOLTS REMOVAL.

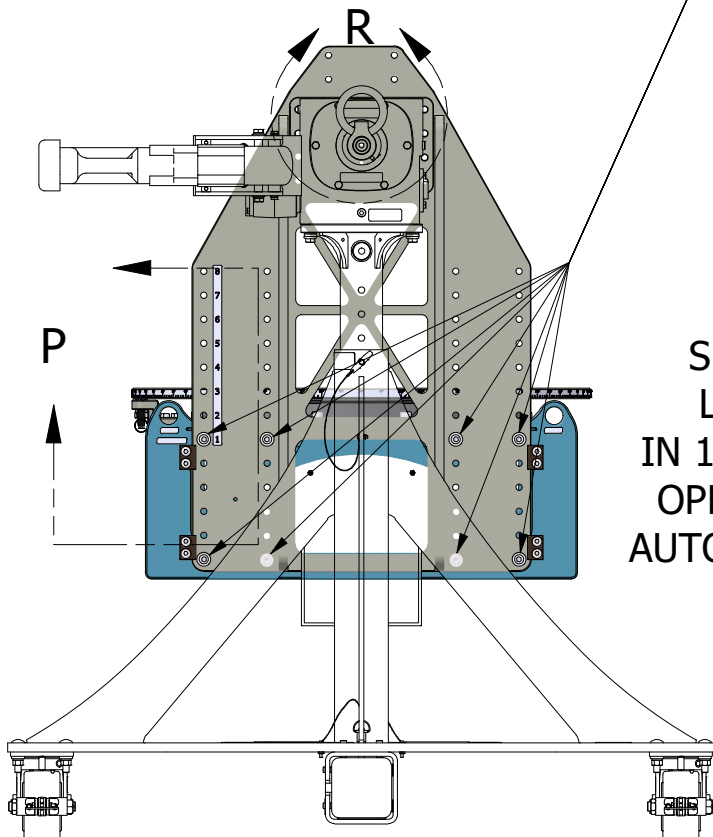

SECONDARY REDUNDANT SPRING LOADED PIN TO LOCK ROTATION IN 15° INCREMENTS. MUST BE HELD OPEN DURING ROTATION AND WILL AUTOMATICALLY SPRING INTO PLACE WHEN RING IS RELEASED.

INTERFACE MUST BE IN PAYLOAD HORIZONTAL ORIENTATION AS SHOWN BEFORE REMOVING ROTATION LOCK PINS. DO NOT REMOVE IN ANY OTHER ORIENTATION.

360° POSITION INDICATOR SCALE

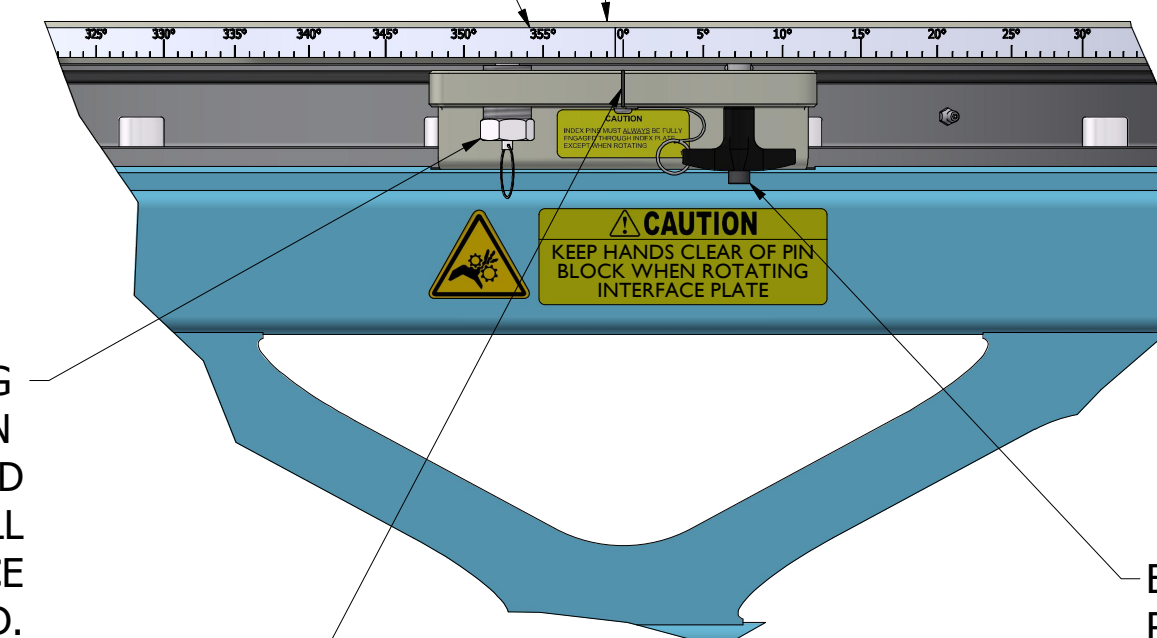

DETAIL N
SCALE 1 : 4

POSITION INDICATOR MARK

SECONDARY AXIS PAYLOAD ADAPTER RING (R)

ADAPTER RING (R)

ADAPTER RING TO CONVERT SA INTERFACE HOLES TO 36X Ø.281 THROUGH HOLES ON A Ø4" BOLT CIRCLE (ESPA GRANDE) WHEN DETERMINING PAYLOAD AND CRADLE CG BALANCE, ADAPTER RING MASS & CG NEEDS TO BE ADDED TO PAYLOAD CG CALCULATIONS

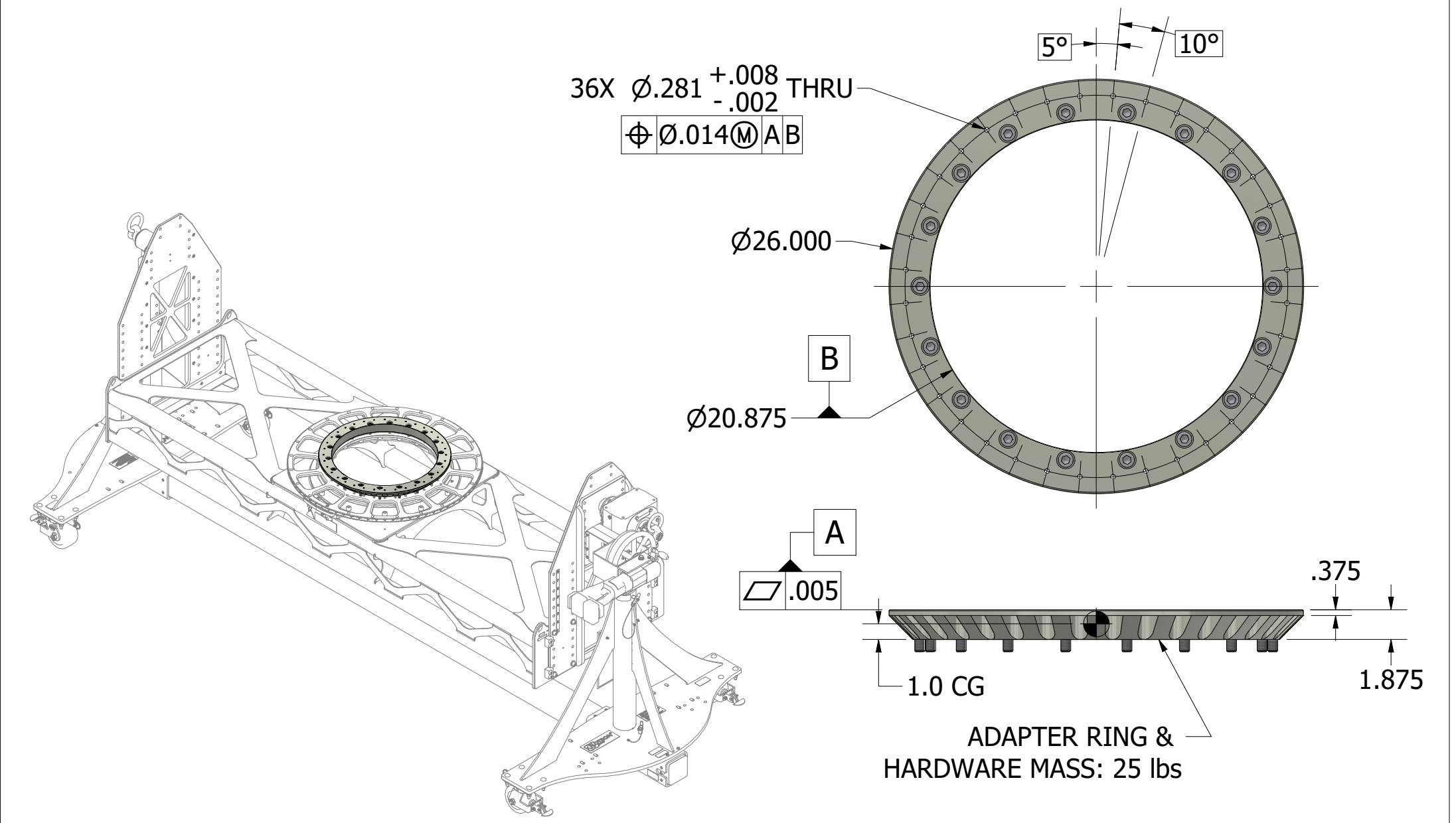

ADAPTER RING & HARDWARE MASS: 25 lbs

BOLT POSITION INDICATOR LABEL. BOLT POSITION SA1 SHOWN.

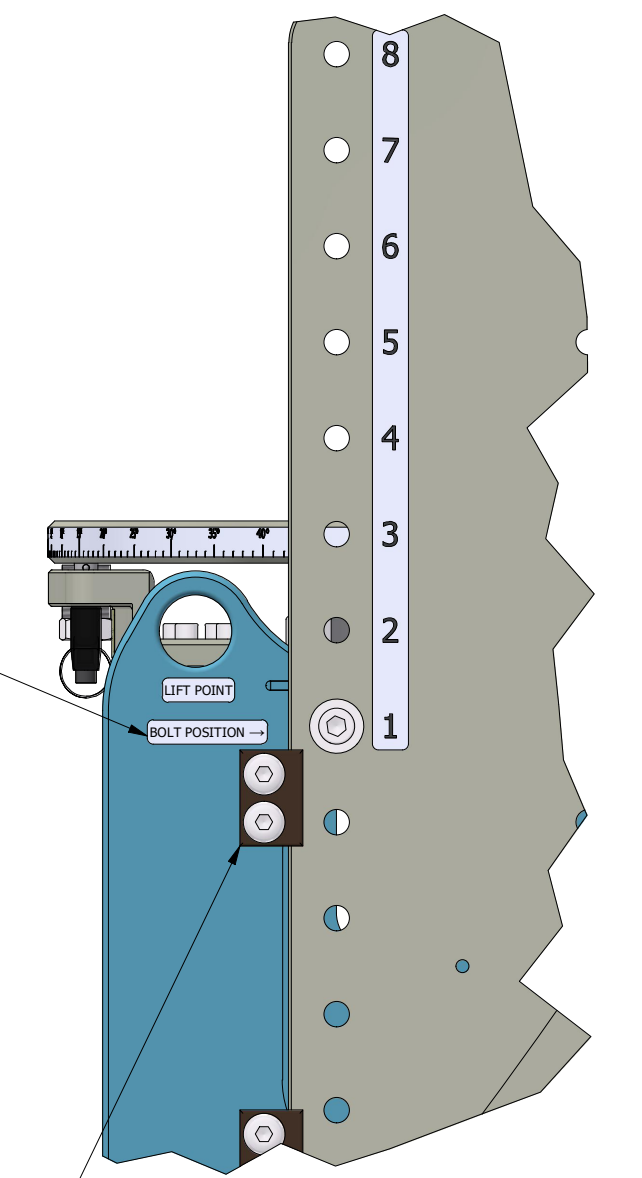

DETAIL P
SCALE 1 : 4

4X GUIDE BLOCKS TO FACILITATE BOLT POSITION ADJUSTMENT

BALL LOCK PIN TO LOCK ROTATION IN 15° INCREMENTS. MUST BE ENGAGED IN A HOLE EXCEPT WHEN ROTATING.

This Drawing is the property of FLOTRON, Inc. and is not to be used, copied or reproduced in any way other than for the particular purpose for which it is provided, and when said purpose has been fulfilled, it should be destroyed or returned to FLOTRON, Inc.

SFP-700 With Secondary Axis or Rotation Dynamic Loading For Cradle **Bolt Position 1**

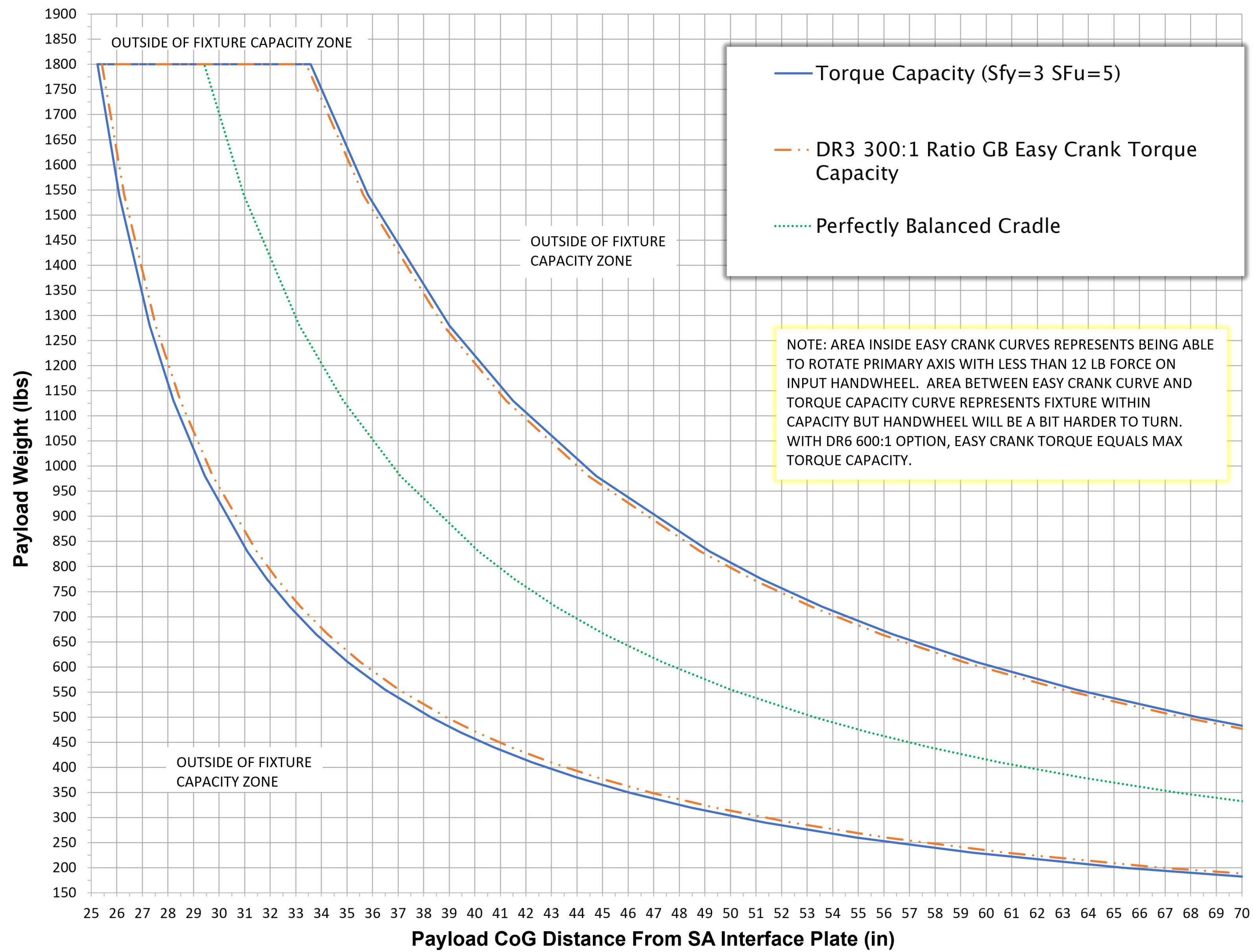

SFP-700 With Secondary Axis or Rotation Dynamic Loading For Cradle **Bolt Position 2**

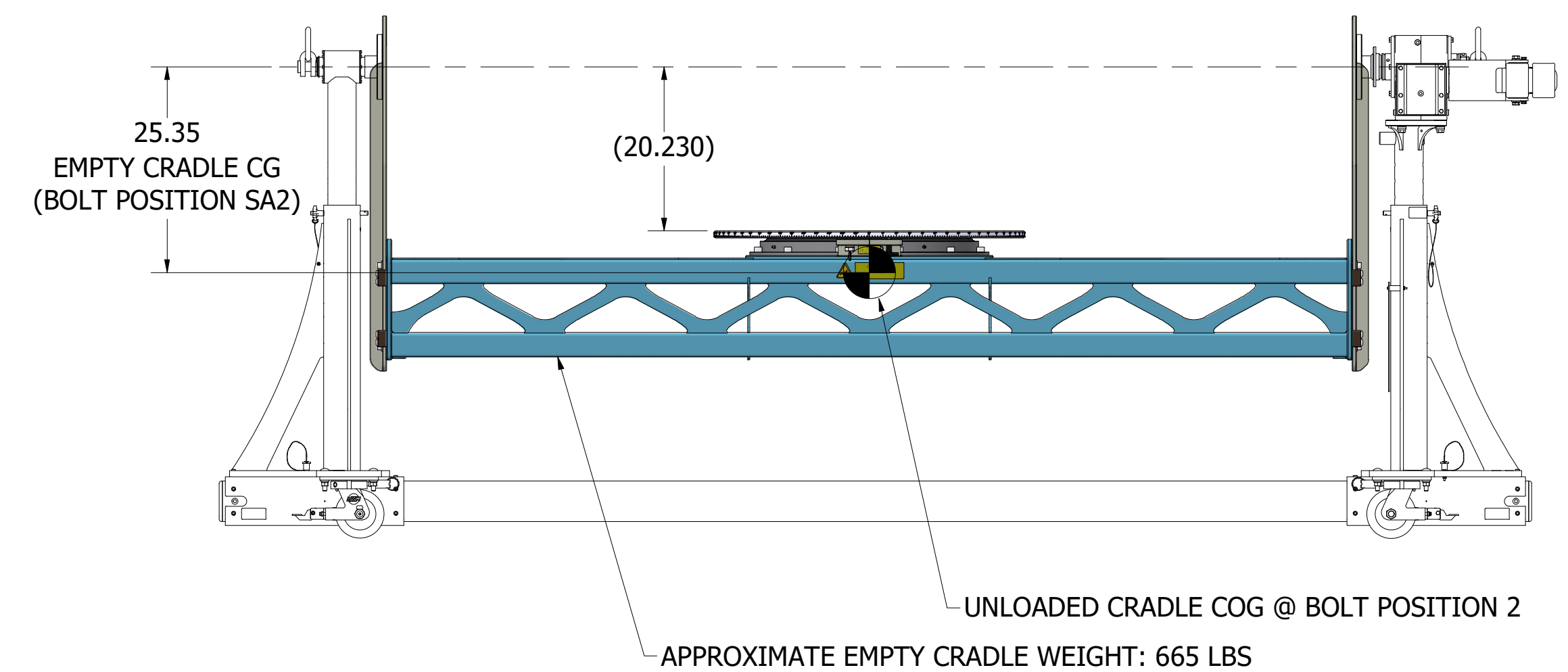
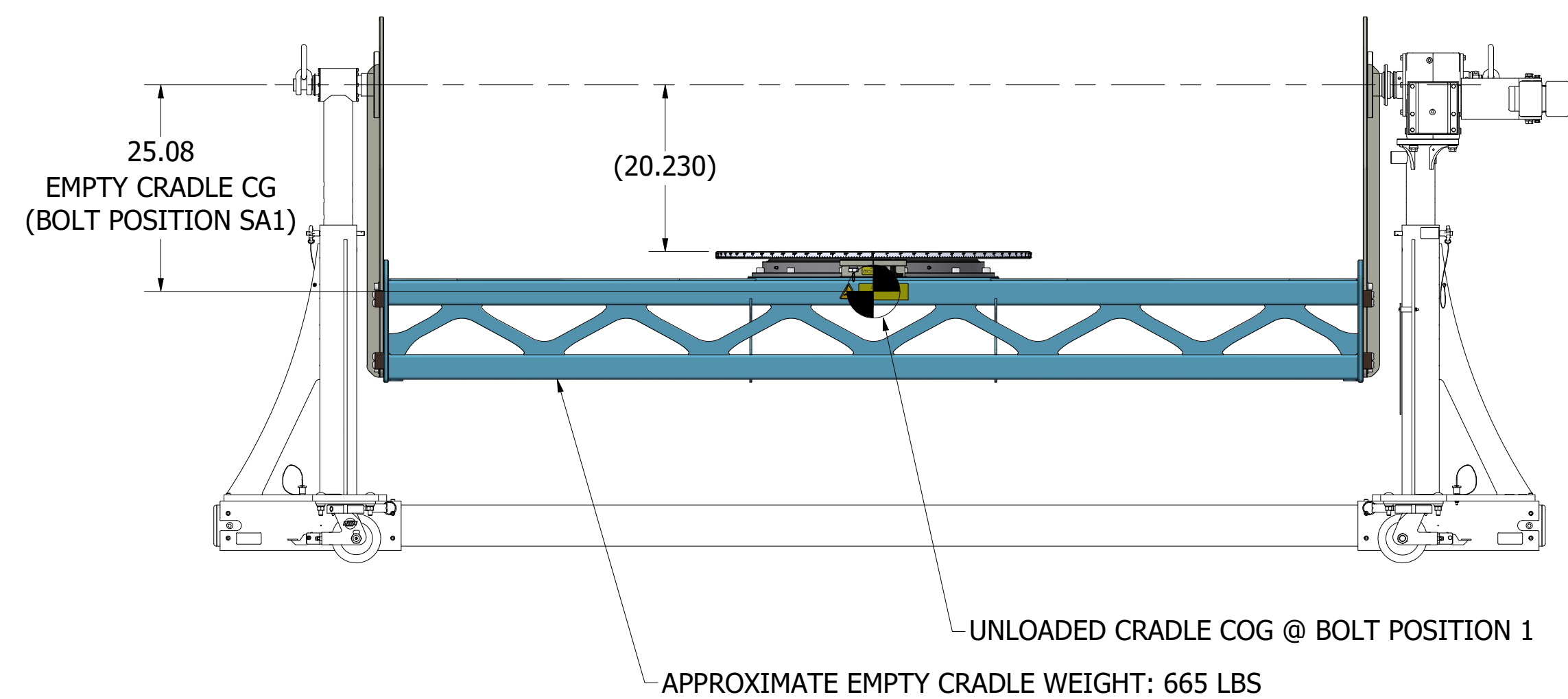
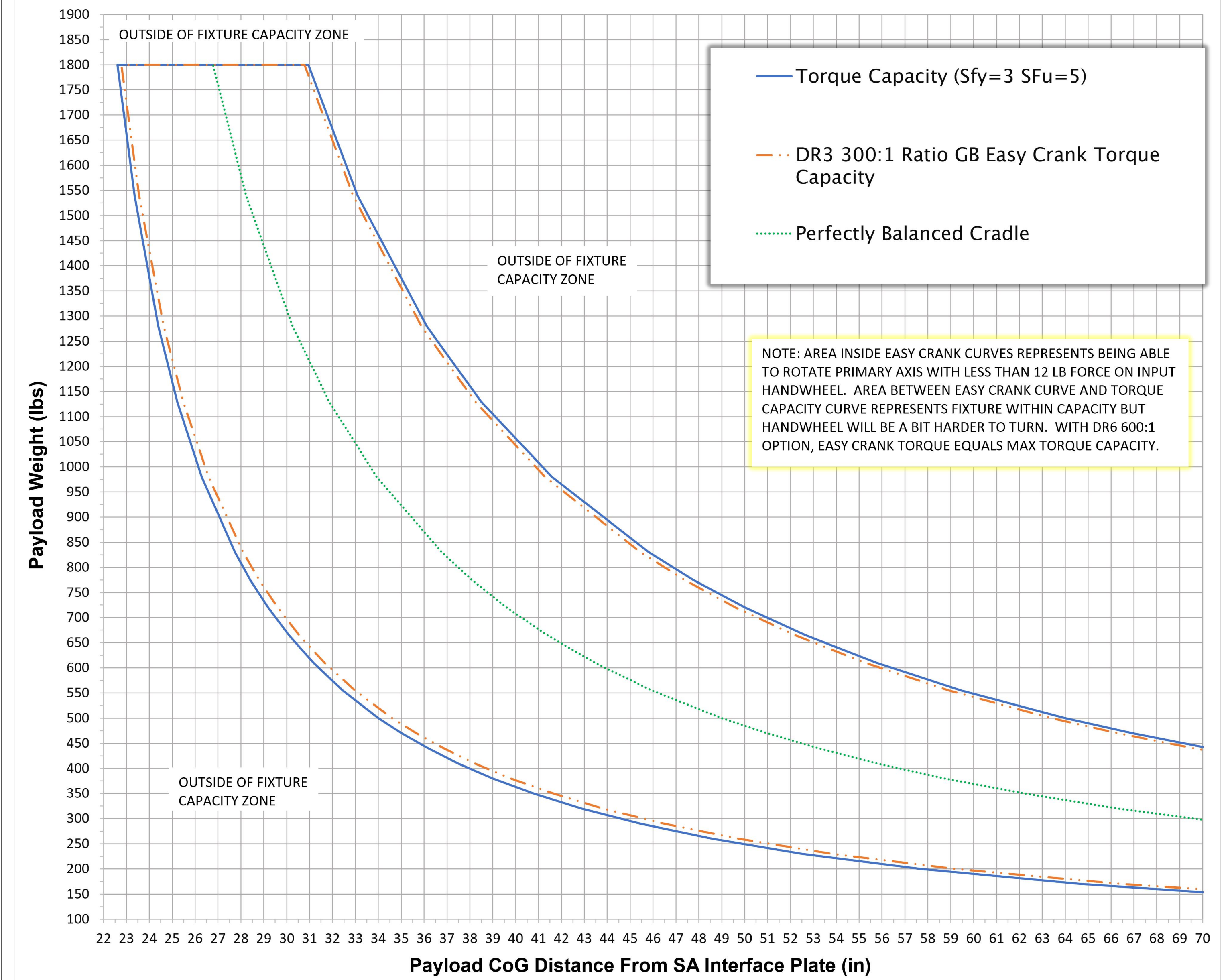

This Drawing is the property of FLOTRON, Inc. and is not to be used, copied or reproduced in any way other than for the particular purpose for which it is provided, and when said purpose has been fulfilled, it should be destroyed or returned to FLOTRON, Inc.

SFP-700 With Secondary Axis or Rotation Dynamic Loading For Cradle **Bolt Position 3**

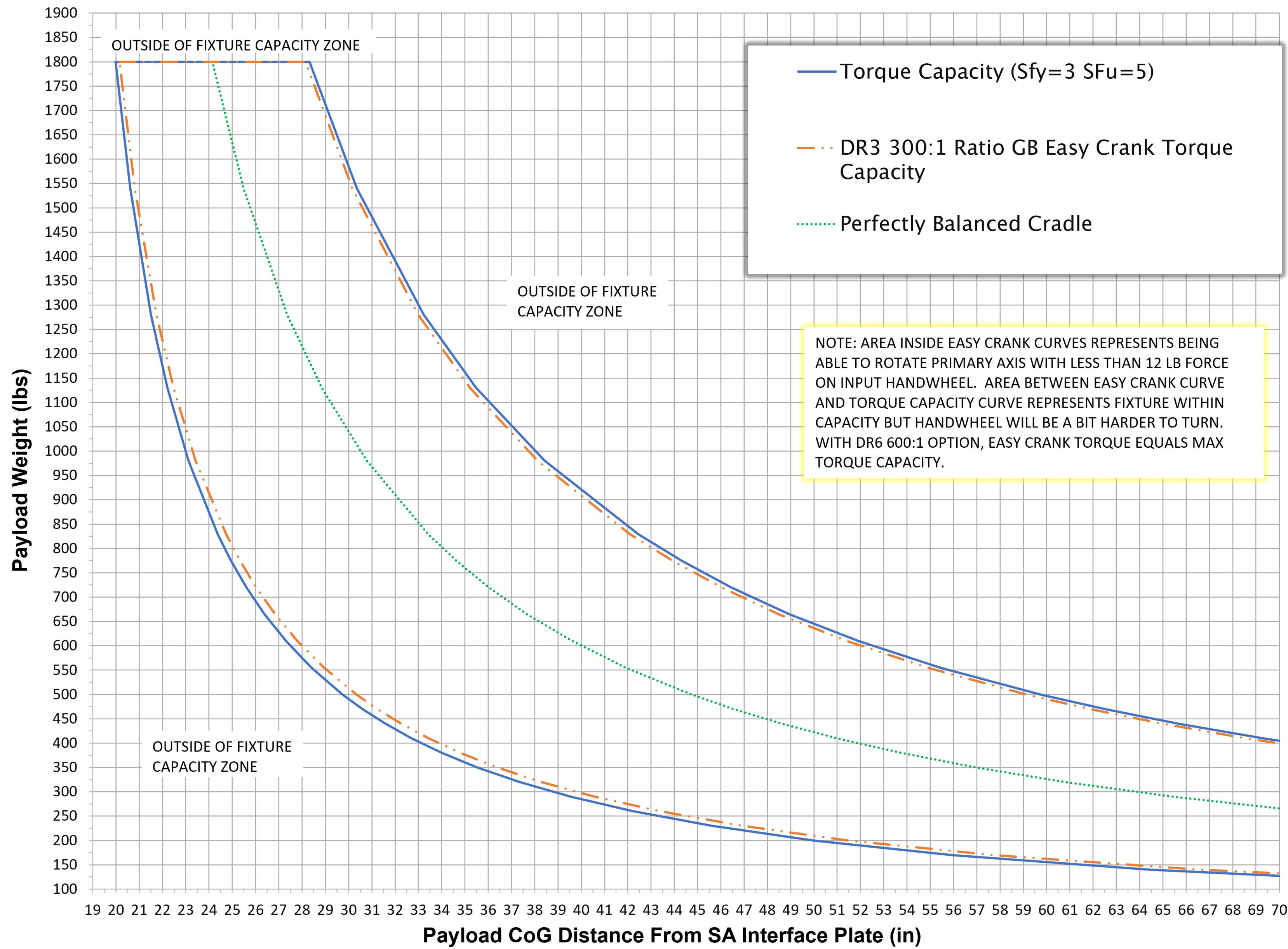

SFP-700 With Secondary Axis or Rotation Dynamic Loading For Cradle **Bolt Position 4**

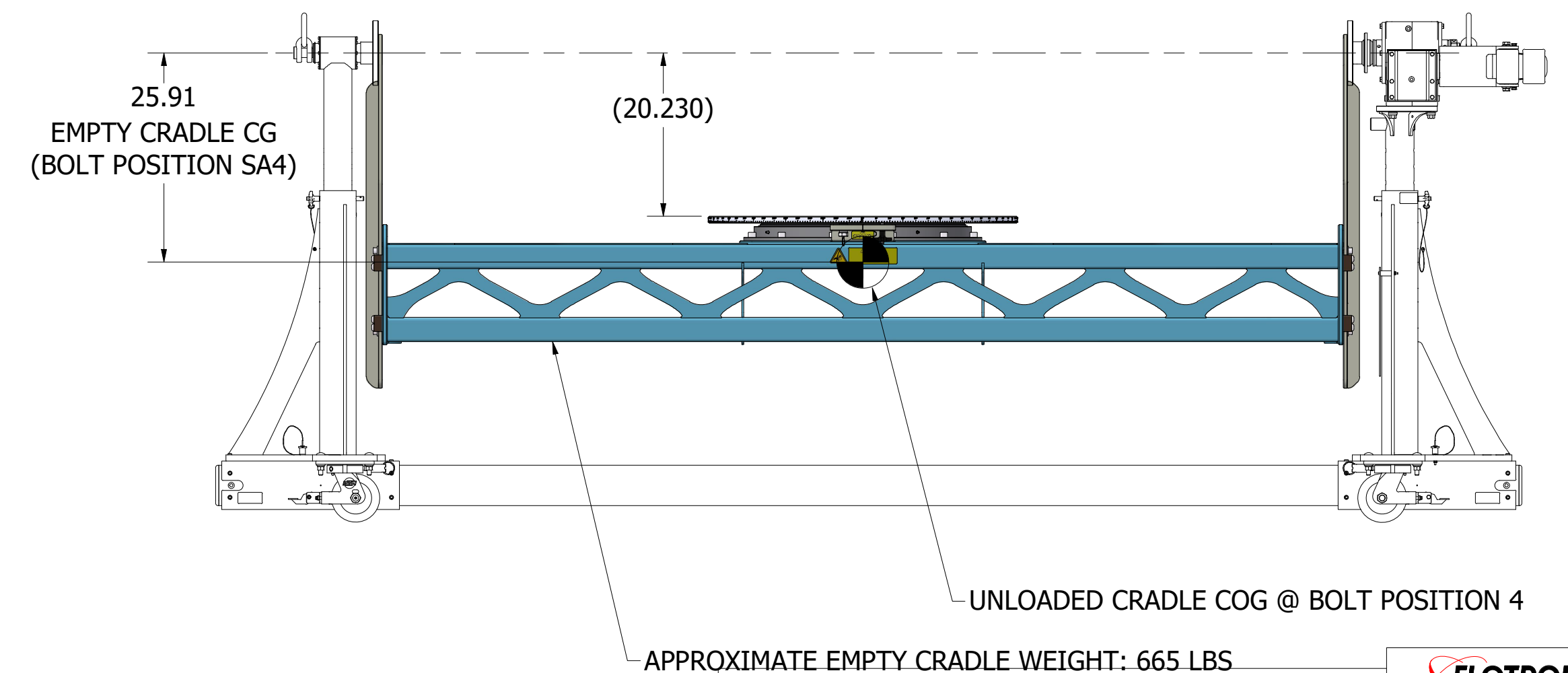
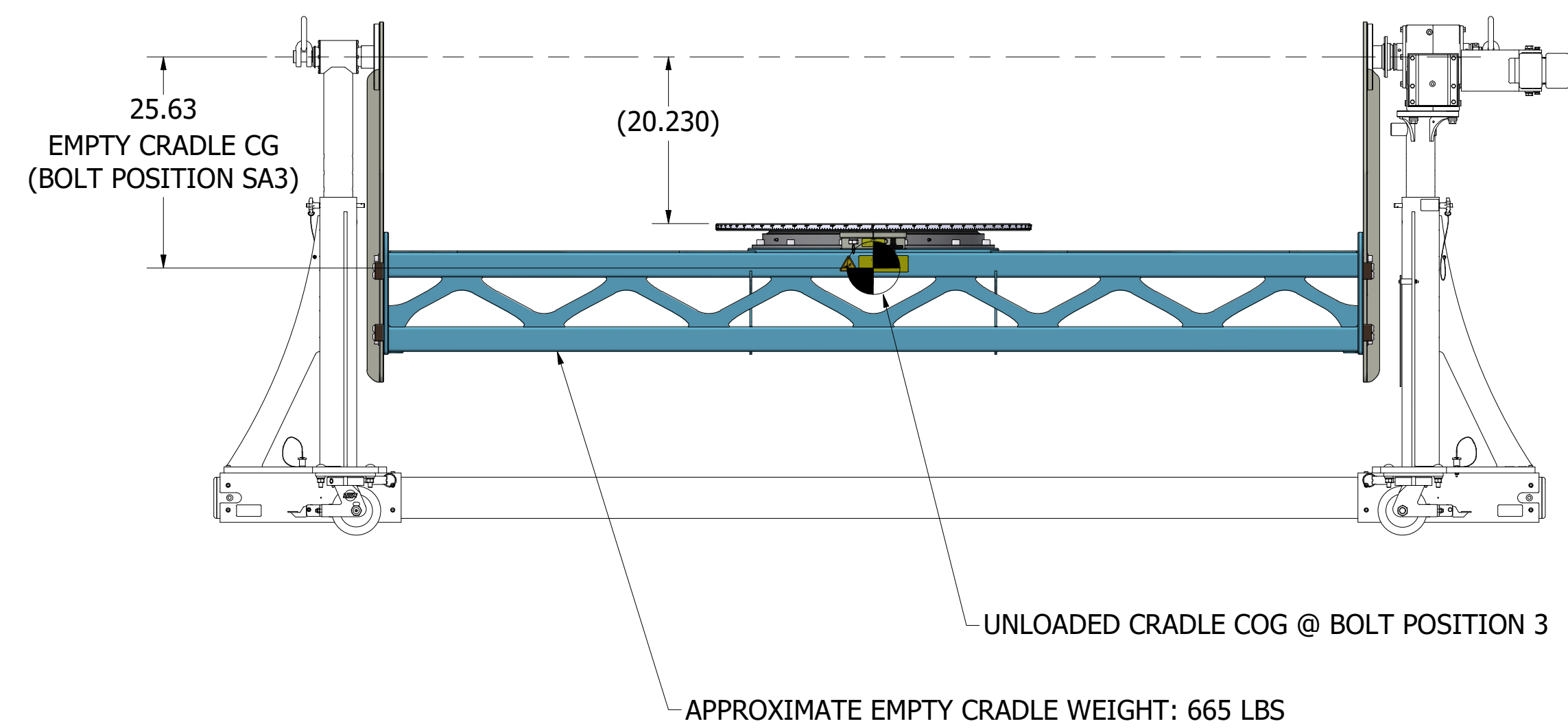
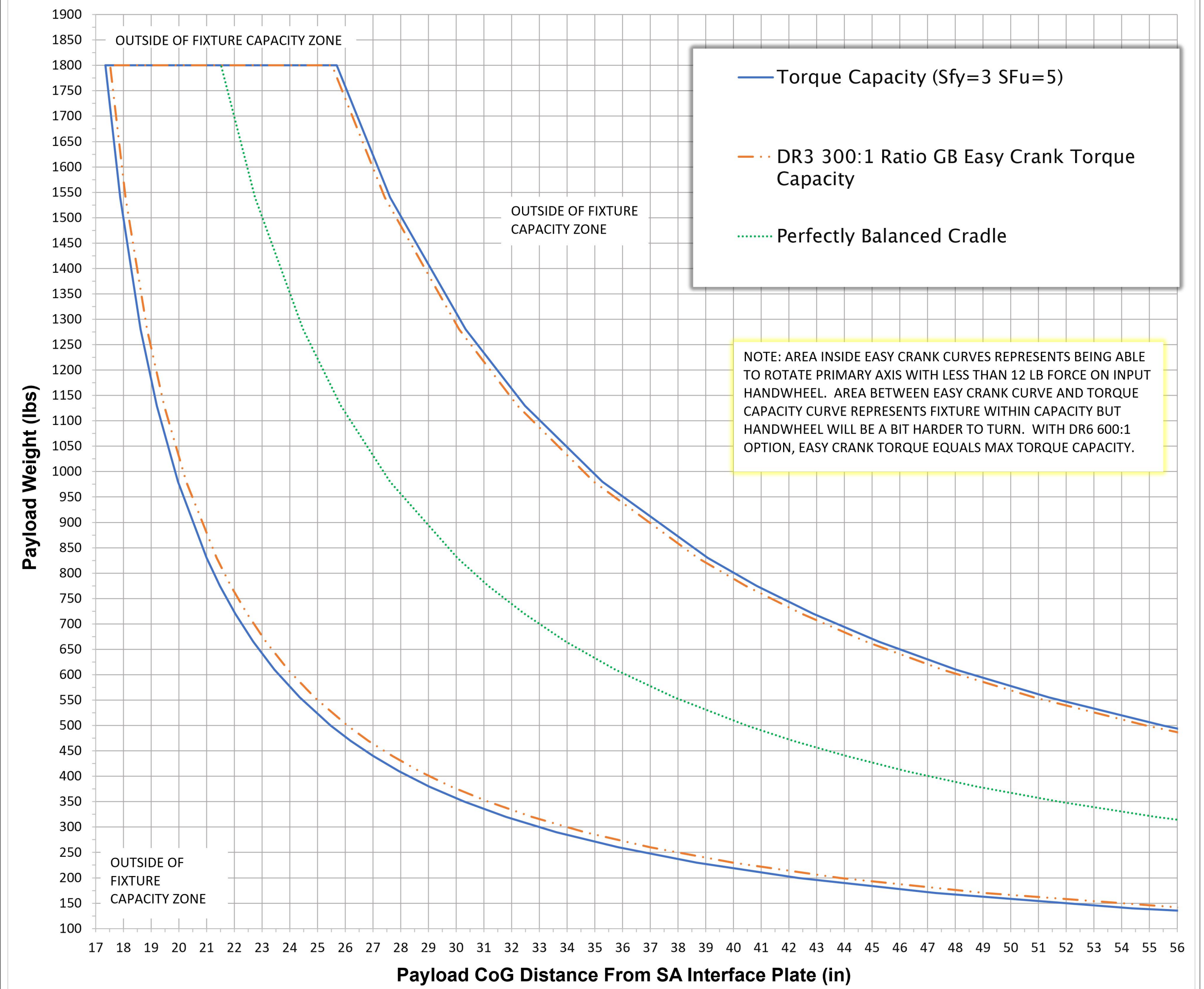

This Drawing is the property of FLOTRON, Inc. and is not to be used, copied or reproduced in any way other than for the particular purpose for which it is provided, and when said purpose has been fulfilled, it should be destroyed or returned to FLOTRON, Inc.

		2630 PROGRESS STREET VISTA, CALIFORNIA 92081 http://www.flotron.com	
SCALE	1 : 10	SIZE	D
		DRAWING NO.	8053-600PROP
		REV	
			SHEET 12 OF 15

SFP-700 With Secondary Axis or Rotation Dynamic Loading For Cradle **Bolt Position 5**

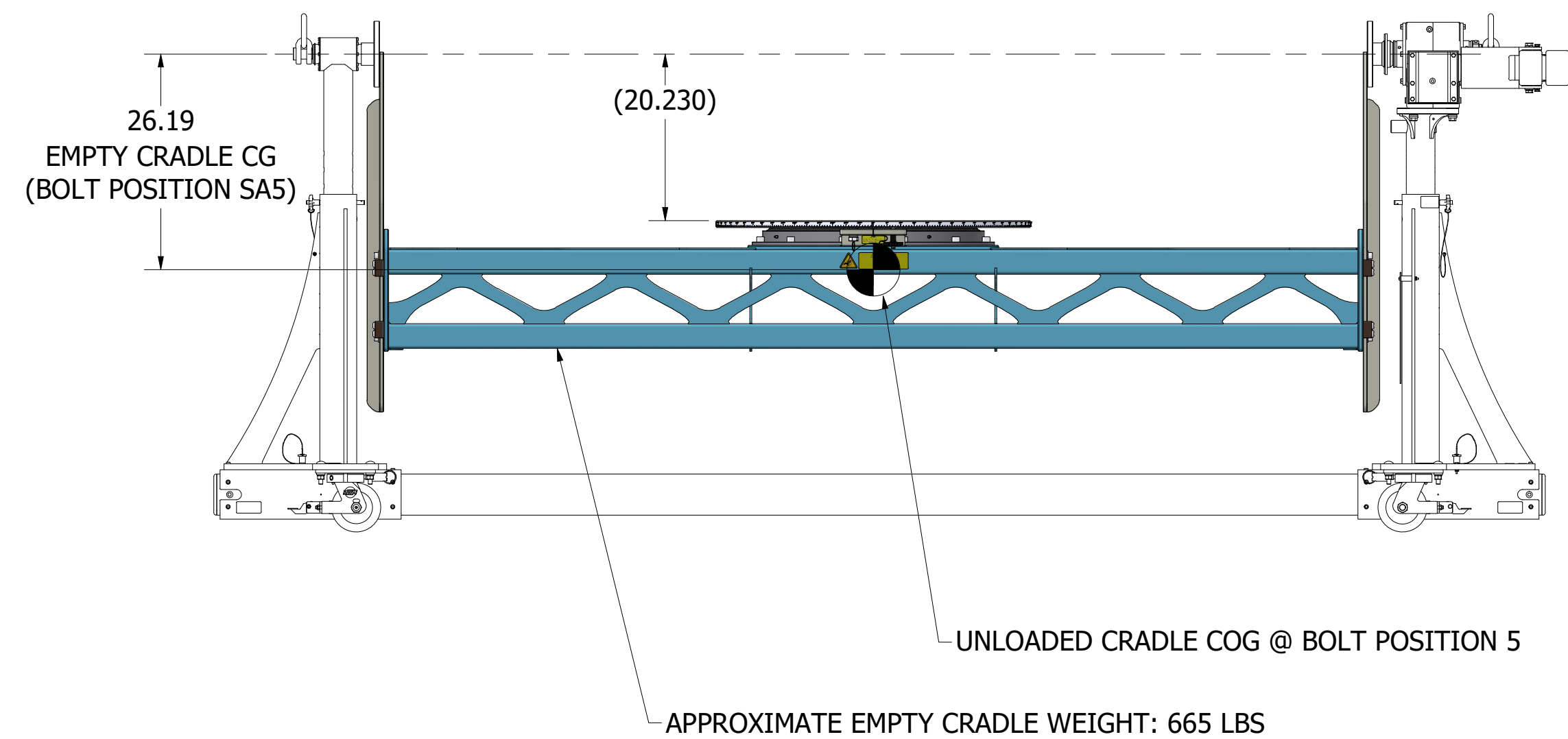
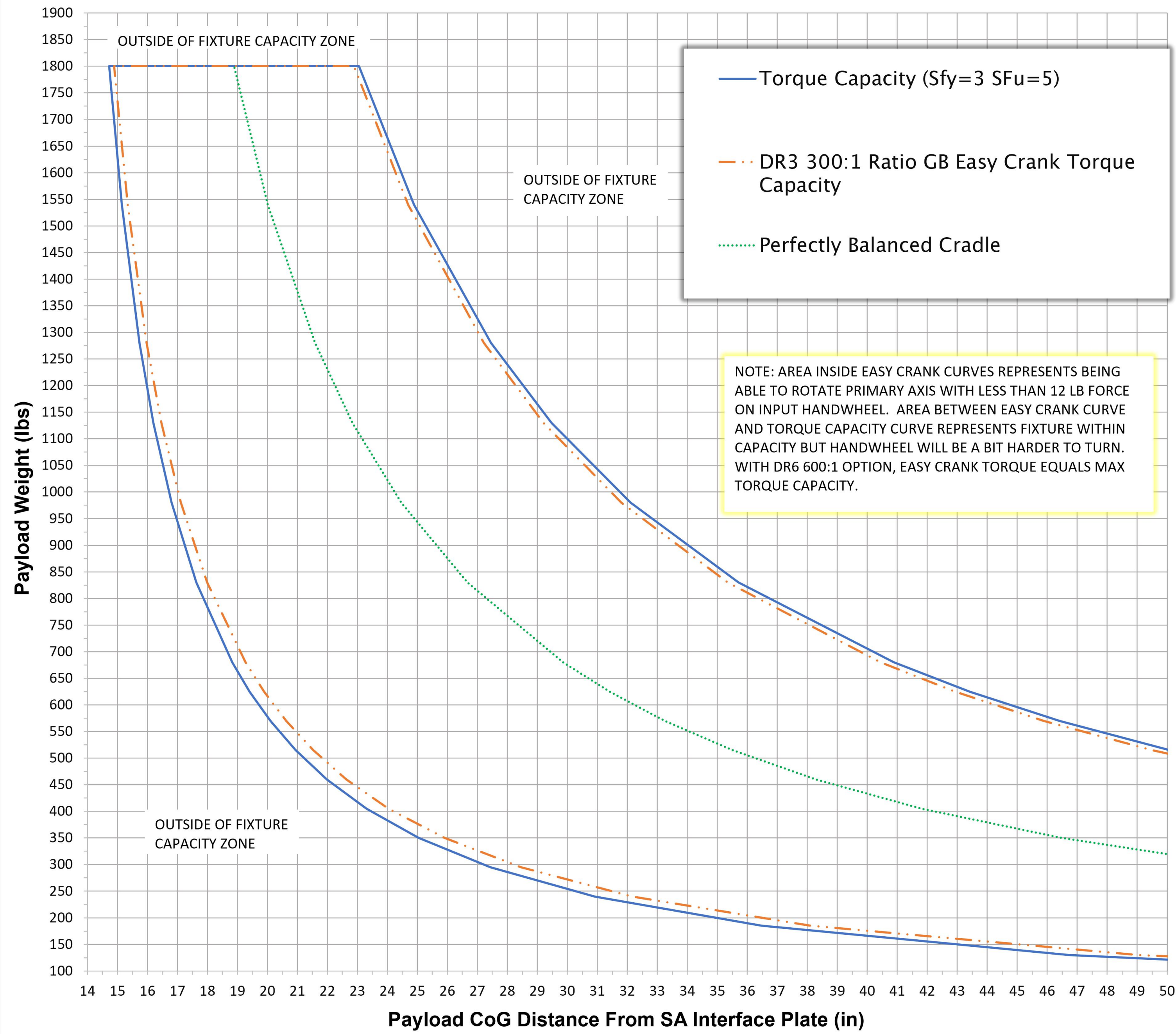

SFP-700 With Secondary Axis or Rotation Dynamic Loading For Cradle **Bolt Position 6**

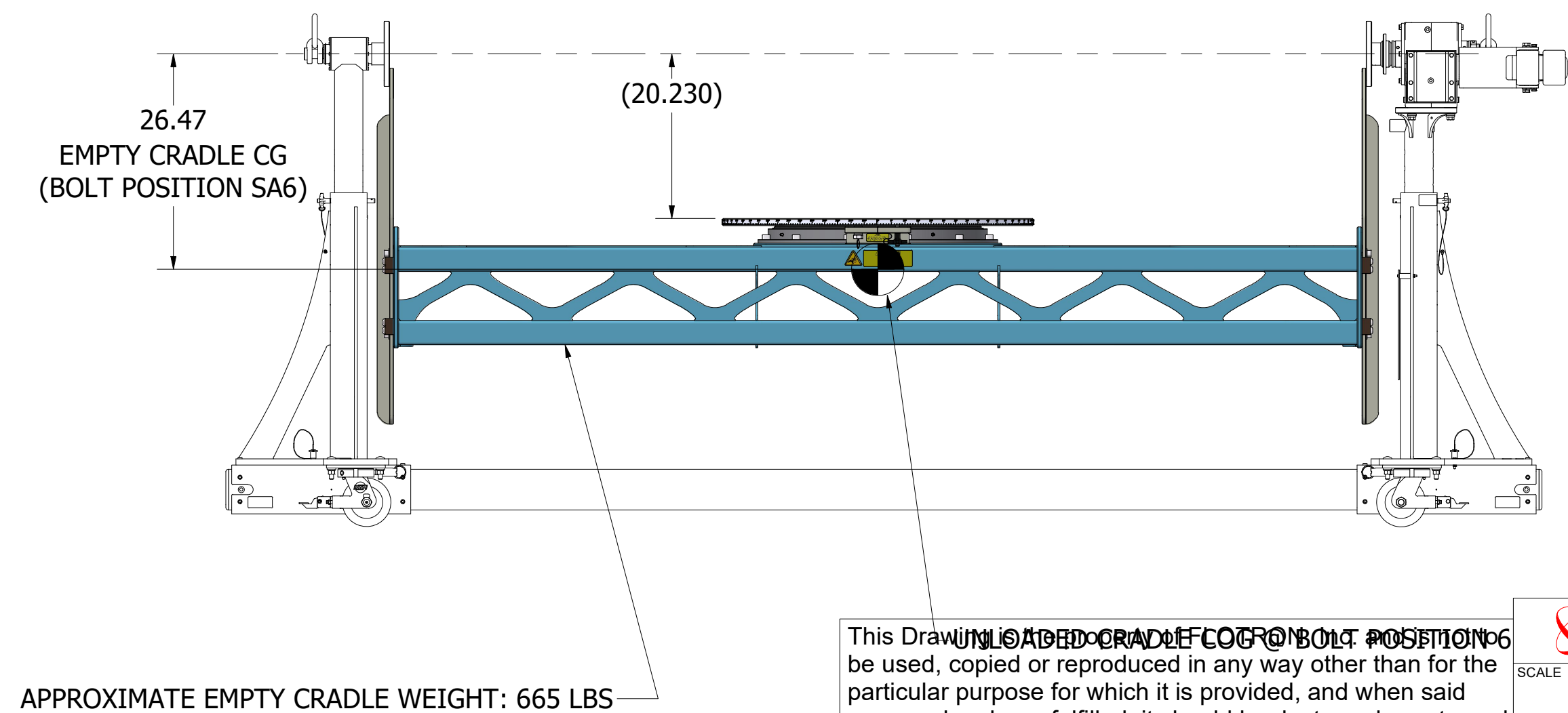
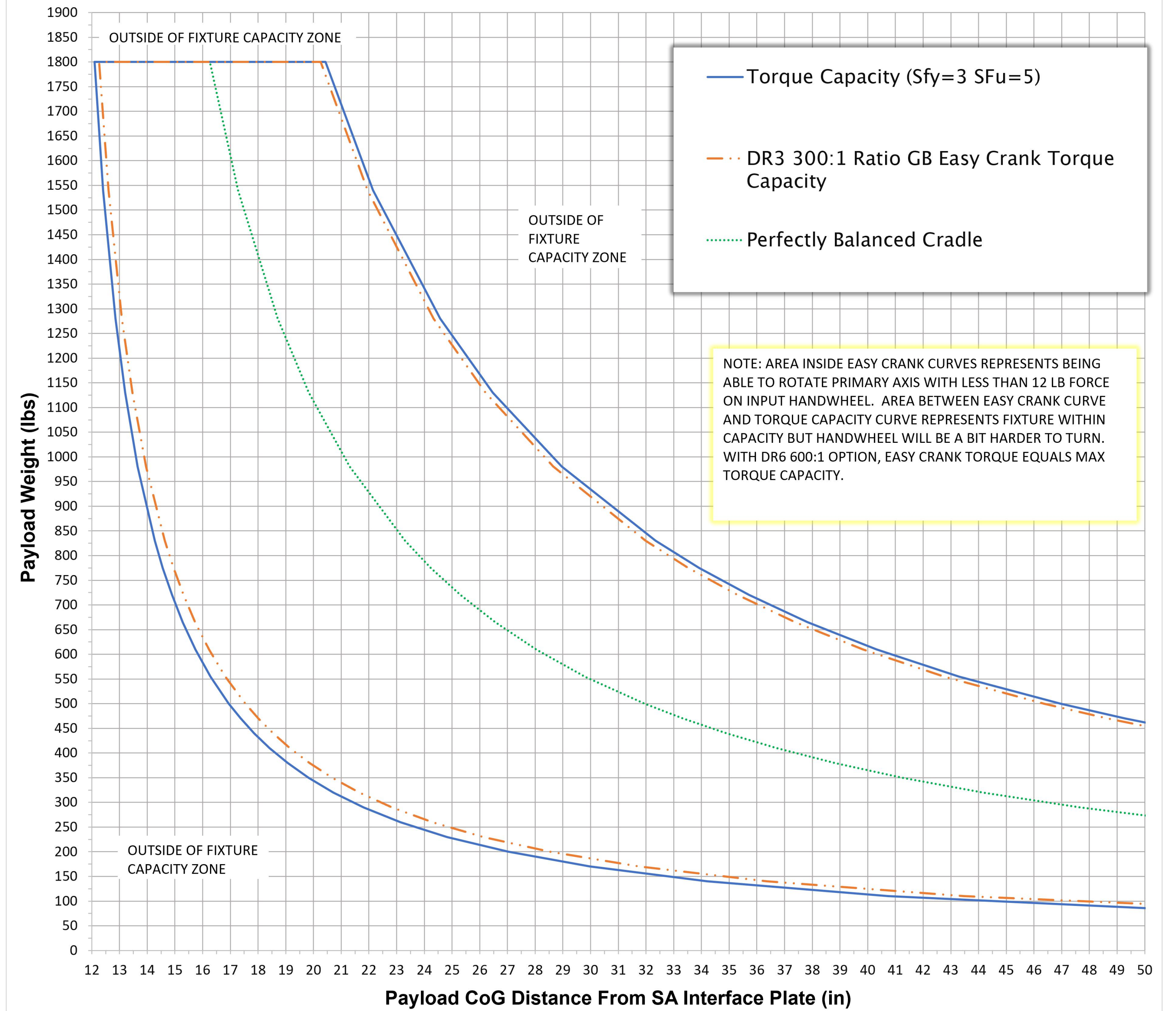

This Drawing is to be used, copied or reproduced in any way other than for the particular purpose for which it is provided, and when said purpose has been fulfilled, it should be destroyed or returned to FLOTRON, Inc.

SFP-700 With Secondary Axis or Rotation Dynamic Loading For Cradle **Bolt Position 7**

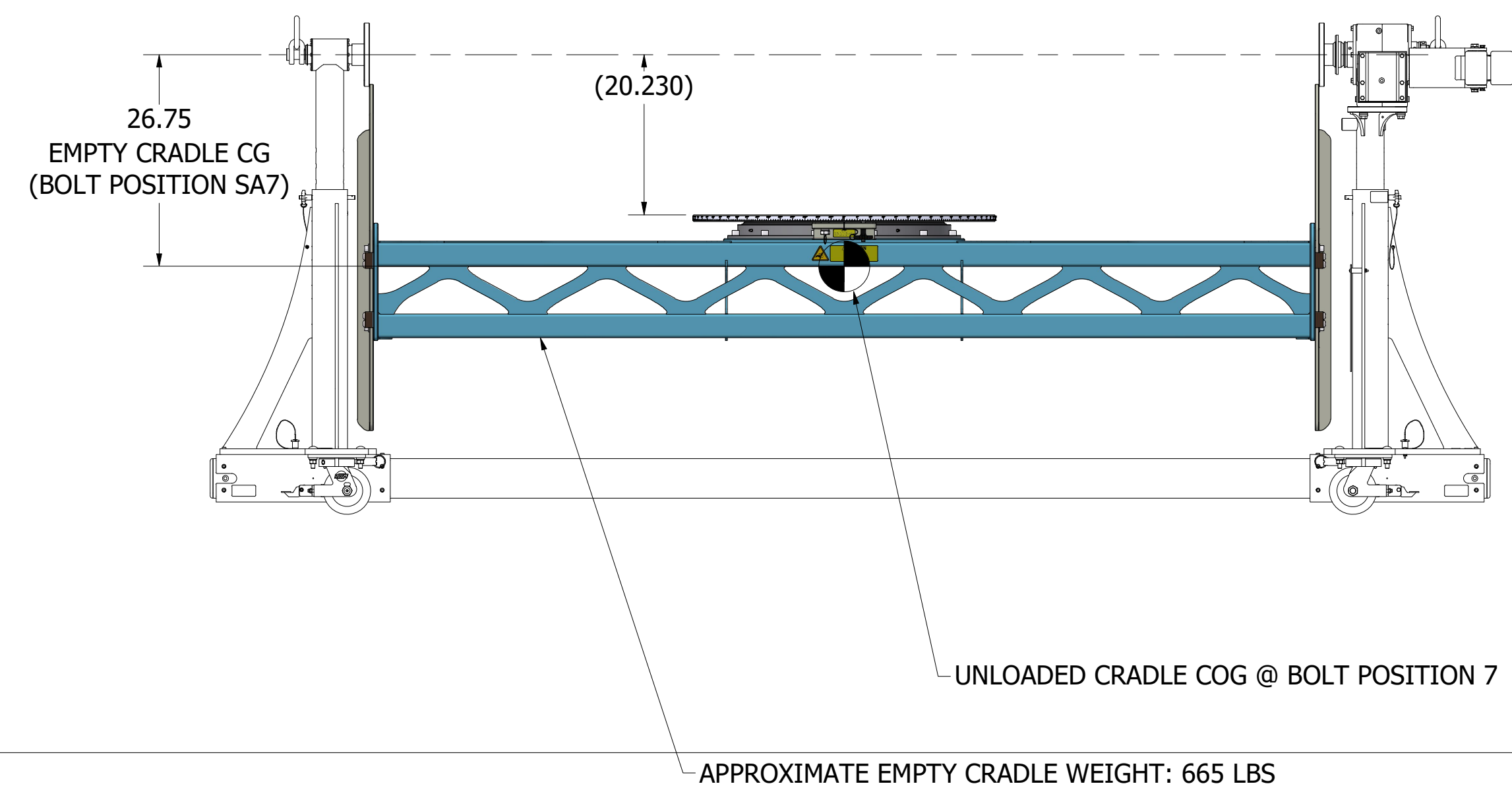
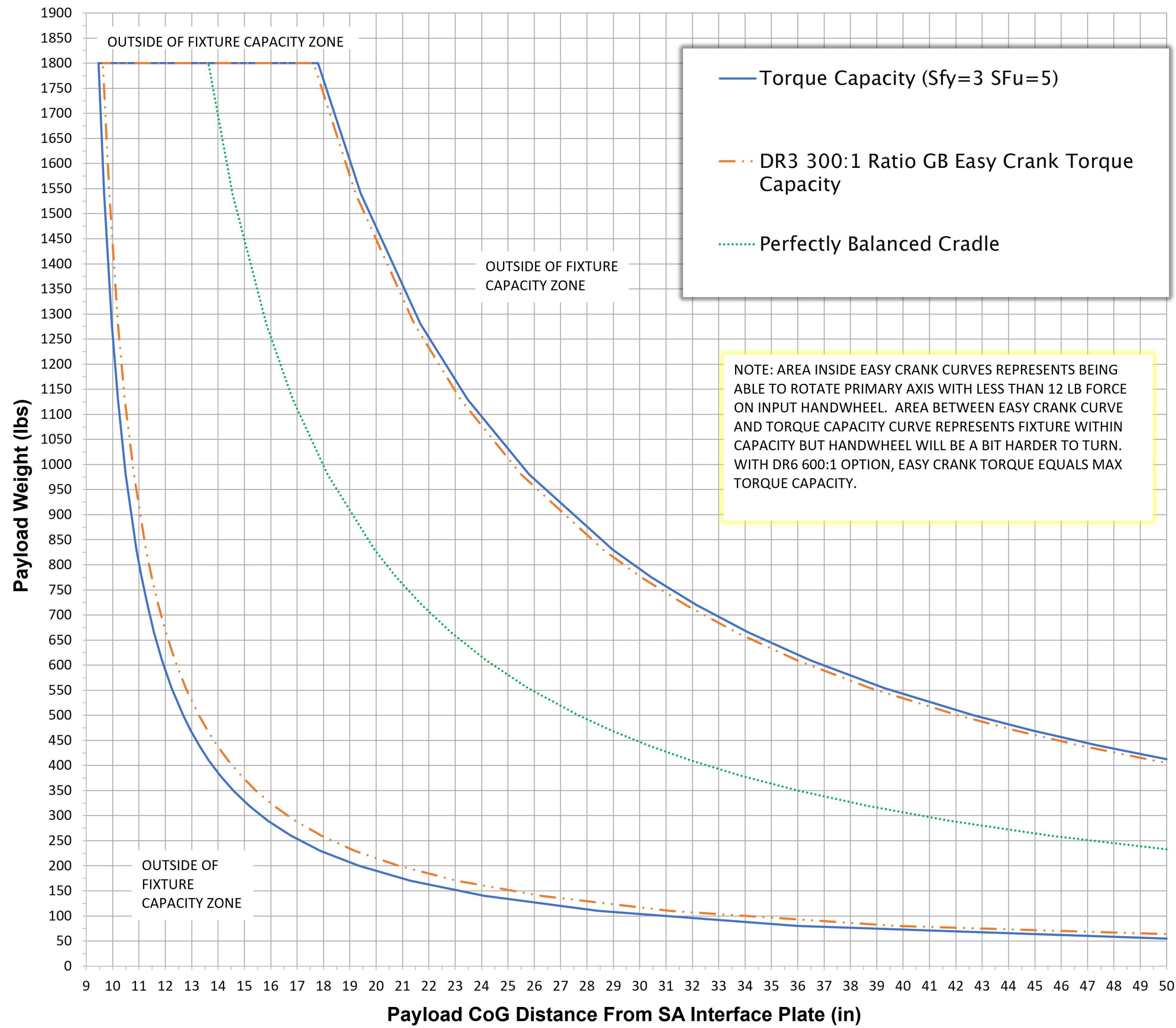

SFP-700 With Secondary Axis or Rotation Dynamic Loading For Cradle **Bolt Position 8**

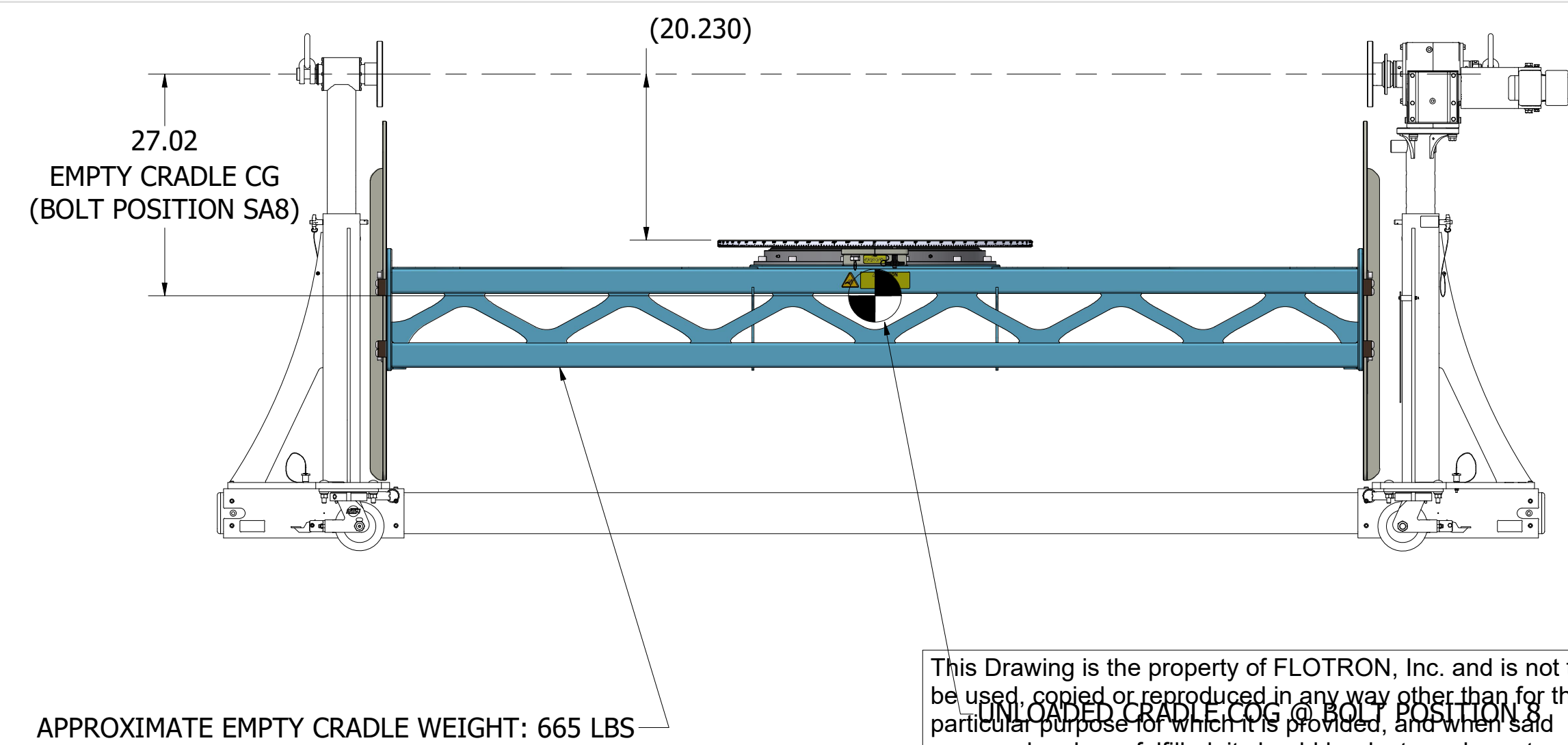
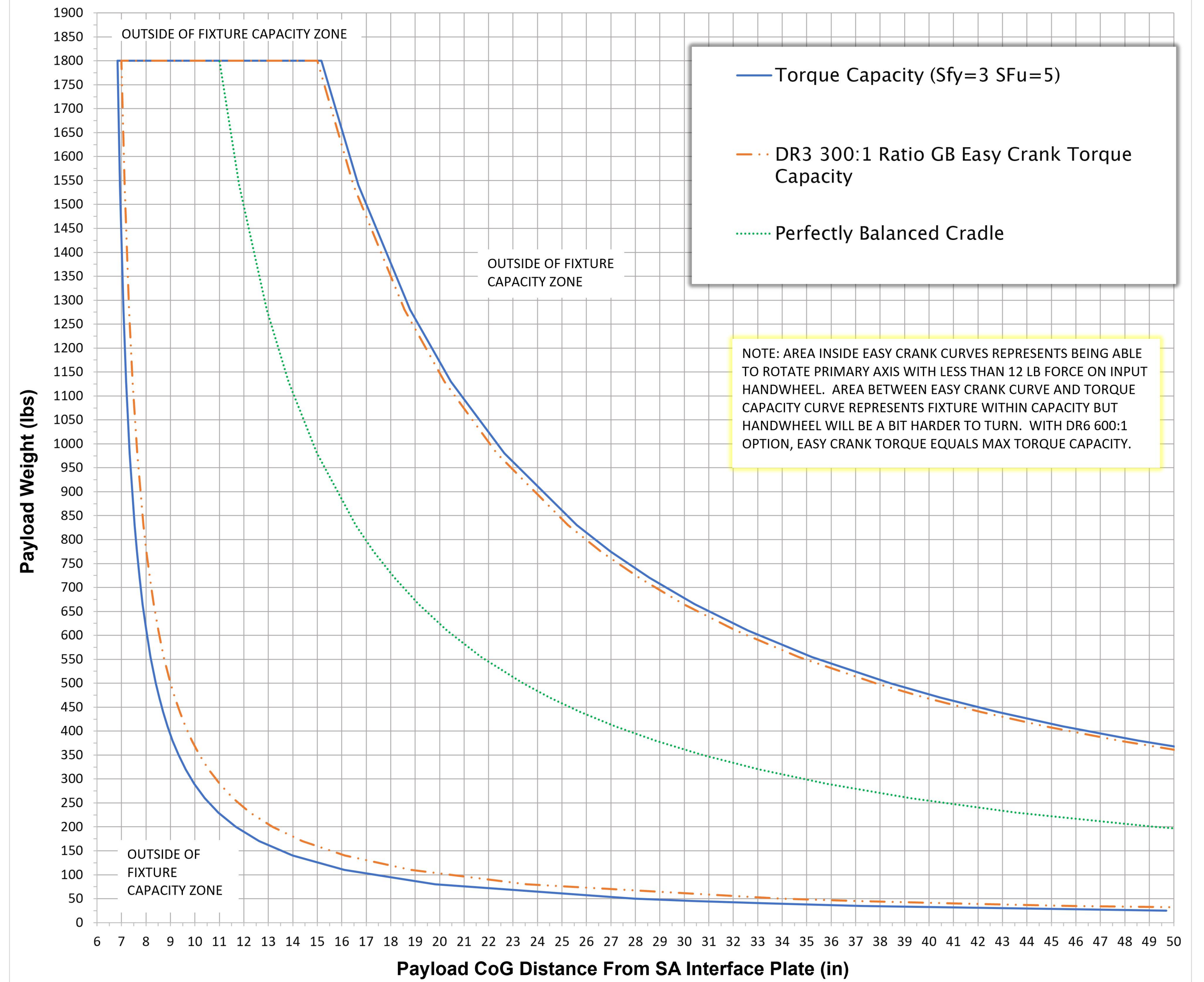

This Drawing is the property of FLOTRON, Inc. and is not to be used, copied or reproduced in any way other than for the particular purpose for which it is provided, and when said purpose has been fulfilled, it should be destroyed or returned to FLOTRON, Inc.

PROOF LOAD TEST (PLT) PROCEDURE

PRIMARY AXIS PROOF LOAD REQUIREMENTS:

PROOF LOAD WEIGHT = 2 X 2,500 LBS = **5,000 LBS (MIN)**
 100% RATED TORQUE = **7,500 IN-LBS (MIN)**

STATIC PROOF LOAD TEST PROCEDURE (DO NOT ROTATE LOAD):

1. VERIFY THAT ALL STRUCTURAL COMPONENTS HAVE BEEN PROPERLY ASSEMBLED AND ALL BOLTS HAVE BEEN TORQUED.
2. WEIGH PROOF LOAD TO MAKE SURE IT MEETS REQUIREMENT AND TAKE A PICTURE OF PROOF LOAD ON SCALE WITH LOAD VALUE ON SCALE VISIBLE FOR PROOF LOAD REPORT.
3. WHILE SUPPORTING PROOF LOAD WEIGHT TORQUE PROOF LOAD MOUNTING BOLTS THEN SLOWLY OFFLOAD PROOF LOAD WEIGHT ONTO FIXTURE.
4. STOP AS REQUIRED TO REVIEW AND INSPECT ANY UNEXPECTED NOISES OR MOVEMENTS.
5. START TIMER, TAKE A PICTURE OF CLOCK ON FIXTURE, AND HOLD FOR (5) FIVE MINUTES.
 AFTER 5 MINUTES, TAKE A SECOND PICTURE OF CLOCK ON FIXTURE AND VISUALLY INSPECT FOR CRACKS, DEFORMATION, ETC.

IF JACK (J5) OPTION IS CHOSEN:

1. LOWER ALL JACKS TO CONTACT THE FLOOR WITHOUT COMPLETELY OFFLOADING WEIGHT FROM CASTERS.
2. AT ONE JACK LOCATION, EXTEND JACK TO RAISE CASTER 1/2" FROM FLOOR.
3. REVIEW THE REMAINING JACK POSITIONS AND DOCUMENT CLEARANCE TO FLOOR IF ANY.
4. EXTEND THE PARTNER JACK MOUNTED ON THE SAME END FRAME TO RAISE THE CASTER 1/2" FROM FLOOR LEVEL.
5. FOLLOW THE PROCEDURE ON THE OPPOSITE END FRAME.
6. START TIMER, TAKE A PICTURE OF CLOCK ON FIXTURE, AND HOLD FOR (5) FIVE MINUTES.
 AFTER 5 MINUTES, TAKE A SECOND PICTURE OF CLOCK ON FIXTURE AND VISUALLY INSPECT FOR CRACKS, DEFORMATION, ETC.

SECONDARY AXIS PROOF LOAD REQUIREMENTS (IF SA OPTION IS CHOSEN):

1. PROOF LOAD WEIGHT = 2 X 1,800 LBS = **3,600 LBS**
2. 100% PRIMARY AXIS RATED TORQUE = **12,000 IN-LBS**
3. 100% SECONDARY AXIS RATED TORQUE = **10,000 IN-LBS**

SECONDARY AXIS PROOF LOAD TEST PROCEDURE (ROTATES LOAD 90°):

1. VERIFY THAT ALL STRUCTURAL COMPONENTS HAVE BEEN PROPERLY ASSEMBLED AND ALL BOLTS HAVE BEEN TORQUED.
2. WEIGH PROOF LOAD TO MAKE SURE IT MEETS REQUIREMENT AND TAKE A PICTURE OF PROOF LOAD ON SCALE WITH LOAD VALUE ON SCALE VISIBLE FOR PROOF LOAD REPORT.
3. WHILE SUPPORTING PROOF LOAD WEIGHT TORQUE PROOF LOAD MOUNTING BOLTS THEN SLOWLY OFFLOAD PROOF LOAD WEIGHT ONTO FIXTURE.
4. STOP AS REQUIRED TO REVIEW AND INSPECT ANY UNEXPECTED NOISES OR MOVEMENTS.
5. START TIMER AND TAKE A PICTURE OF TIMER. HOLD FOR (5) FIVE MINUTES. AFTER 5 MINUTES VISUALLY INSPECT FOR CRACKS, DEFORMATION, ETC. TAKE ANOTHER PICTURE OF TIMER.
6. ROTATE PROOF LOAD 90°, START TIMER AND TAKE A PICTURE OF TIMER. HOLD FOR (5) FIVE MINUTES. AFTER 5 MINUTES VISUALLY INSPECT FOR CRACKS, DEFORMATION, ETC. TAKE ANOTHER PICTURE OF TIMER.

DELIVERABLE REPORT REQUIRED. IT MUST INCLUDE:

- A) A SUMMARY OF THE TEST PROCEDURE
- B) A PICTURE OF THE ACTUAL MEASURED WEIGHT OF PROOF LOAD ON SCALE.
 WEIGHT MUST BE EQUAL TO OR HIGHER THAN REQUIRED WEIGHT.
- C) PICTURE OF TIMER WITH PROOF LOAD THAT SHOWS 5 MINUTES OR LONGER FOR EACH TEST.
- D) VISUAL INSPECTION RESULTS

SFP-759 Dynamic Loading
 (1.0 G Vertical & 0.5 G Horizontal)

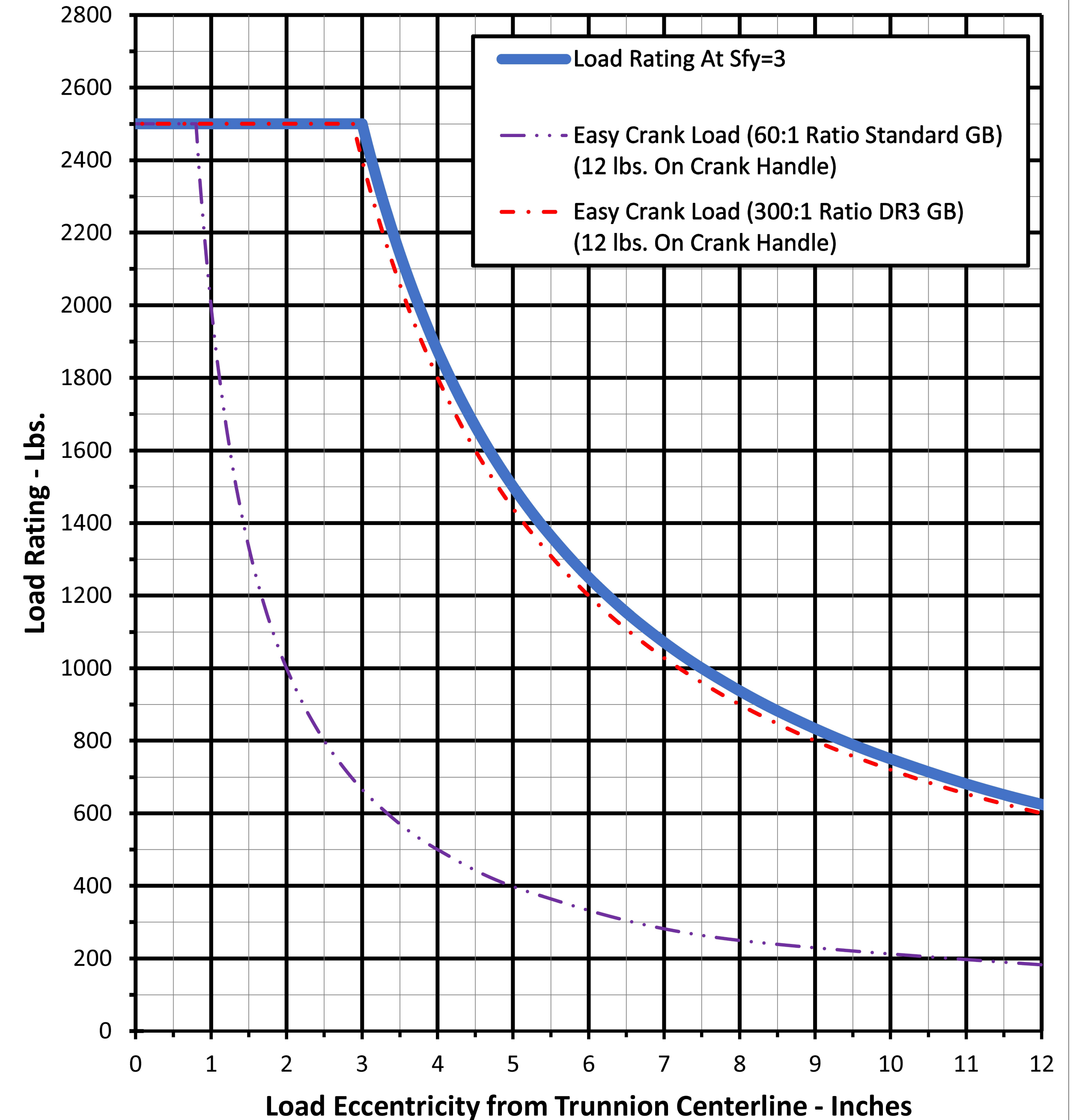

This Drawing is the property of FLOTRON, Inc. and is not to be used, copied or reproduced in any way other than for the particular purpose for which it is provided, and when said purpose has been fulfilled, it should be destroyed or returned to FLOTRON, Inc.