

FLOTRO BLUE COLOR (SHOWN) FOR "STANDARD" FINISH. FRAMES AND GEARBOX ARE SKY WHITE FOR "C" FINISH.

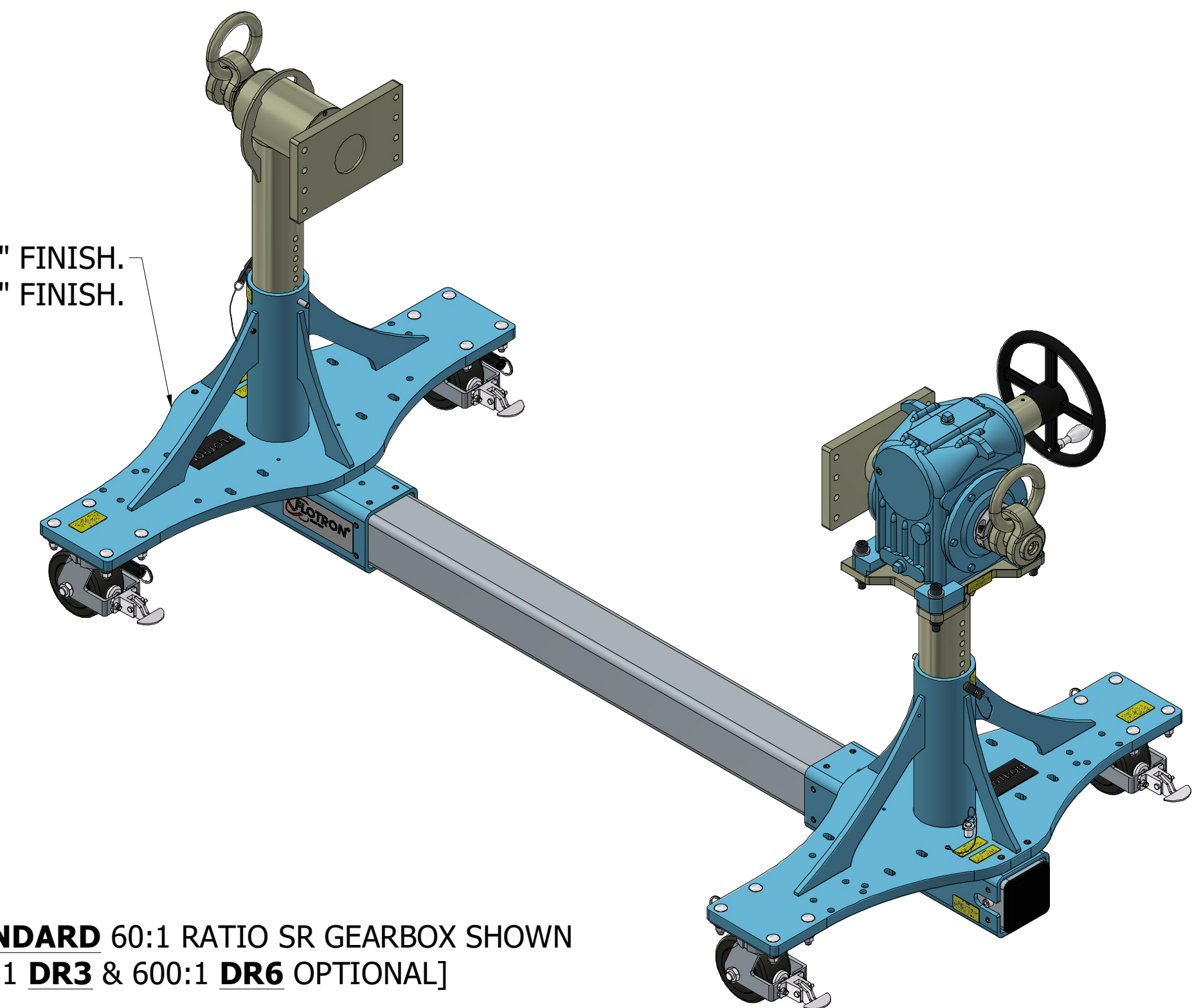

2X LIFT RINGS CAPABLE OF LIFTING FIXTURE WITH PAYLOAD INTEGRATED. 45° MIN LIFT ANGLE OR SPREADER BEAM REQUIRED

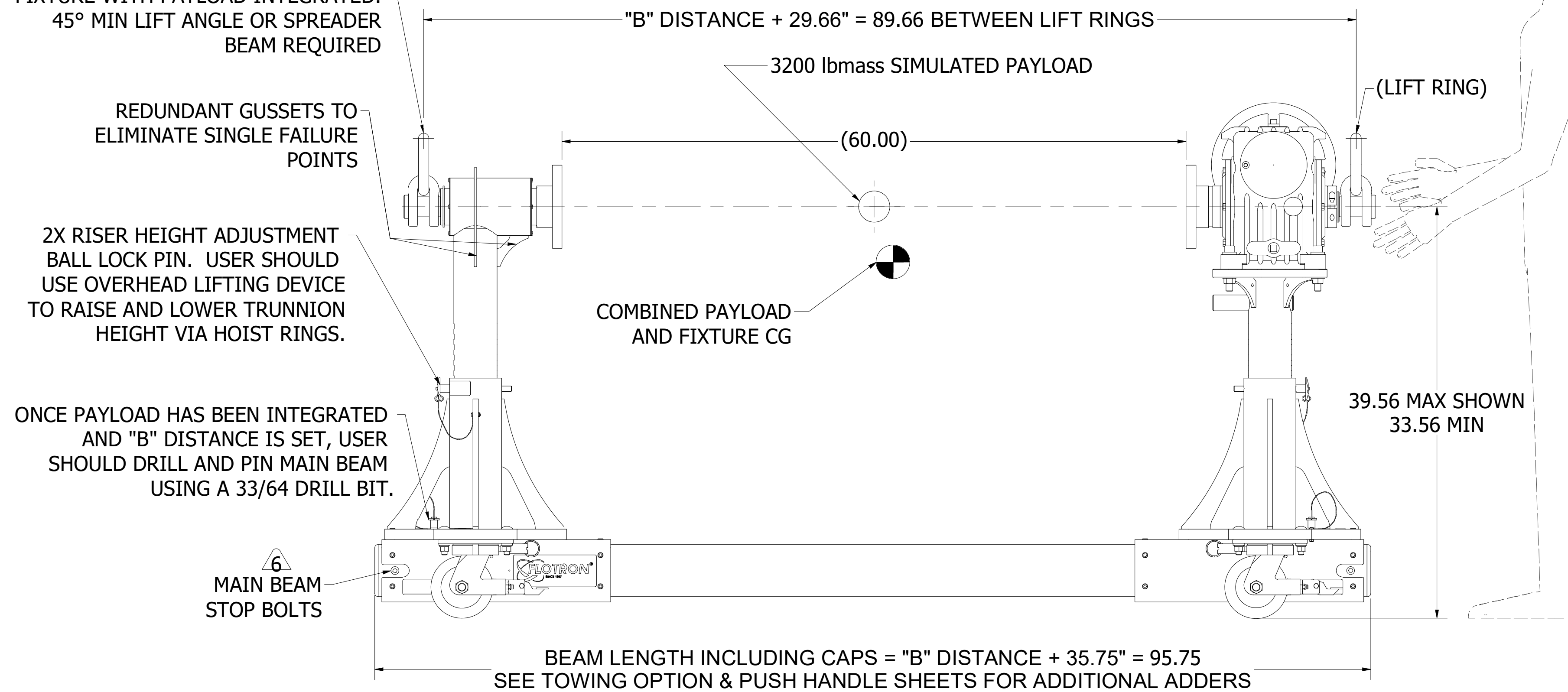

STANDARD 60:1 RATIO SR GEARBOX SHOWN [300:1 DR3 & 600:1 DR6 OPTIONAL]

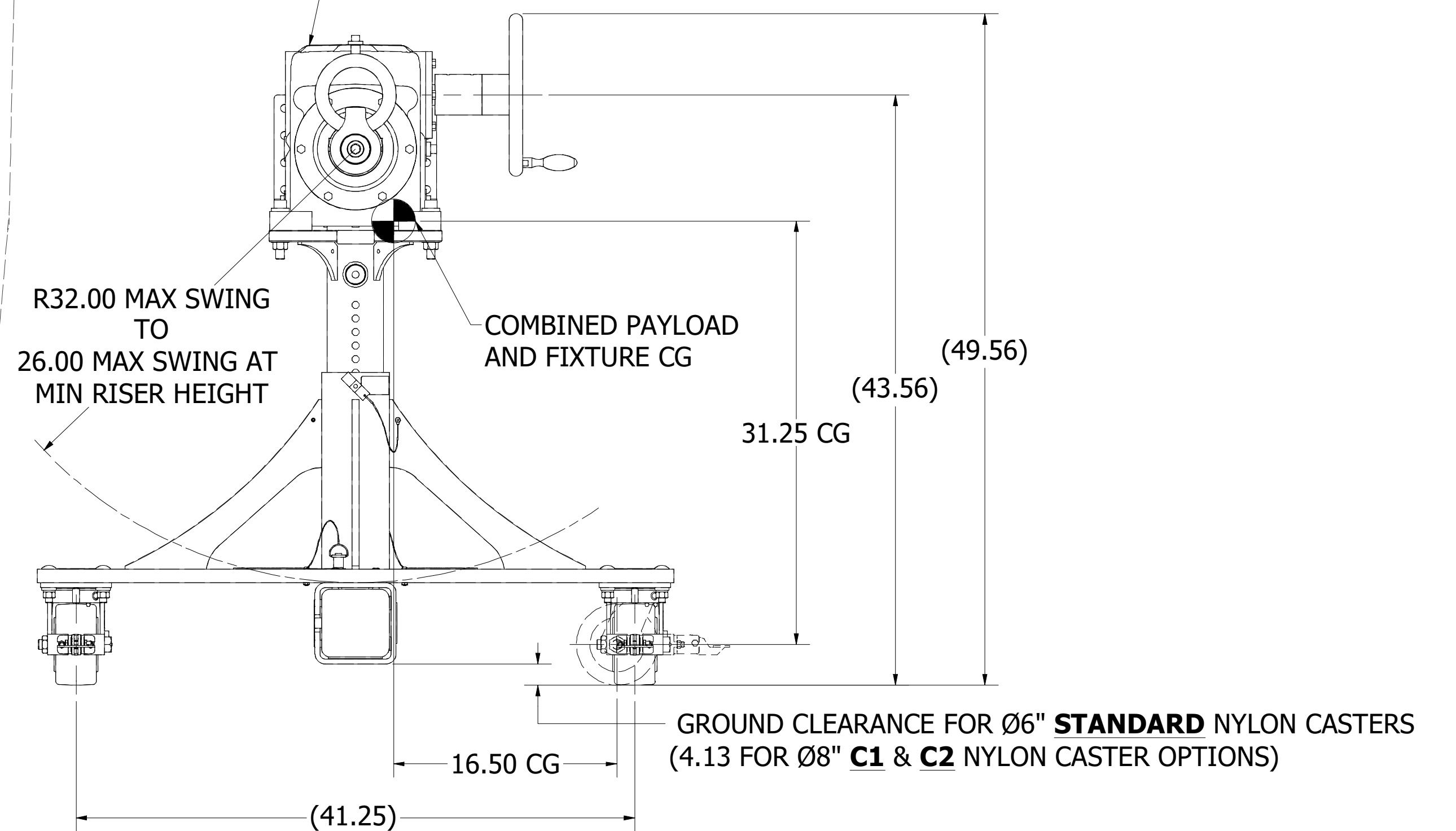

FOR VERY LONG FIXTURES, MAIN BEAM END CAPS, STOP BOLTS AND NUTS MAY BE SHIPPED LOOSE AND INSTALLED BY CUSTOMER. TORQUE MAIN BEAM STOP BOLTS TO 42-47 FT-LBS (DRY).

SEE SHEET 3 FOR CONFIGURATION OPTIONS. SEE ADDITIONAL SHEETS FOR MORE DETAILED INFORMATION ON OPTIONS.

CONFIGURATION SHOWN ON THIS SHEET: SFP-847-P12-B060

FINISHES:

A. "STANDARD" FLOTRO FINISHES (SHOWN) - CLASS 10K (ISO 7 CLEANROOM COMPATIBLE FINISHES) - FLOTRO BLUE POWDER COATED END FRAMES, GEARBOX PAINTED FLOTRO BLUE, NICKEL PLATED COMPONENTS (NO ZINC), STAINLESS STEEL, OR BLACK OXIDE FASTENERS AND MISC. HARDWARE. LUBRICATE CASTER SWIVEL BEARINGS AND TRUNNION NEEDLE ROLLER BEARINGS WITH STA-LUBE SL3131 HEAVY DUTY DRUM BRAKE GREASE. (KRYTOX GPL 207 FOR FASTENERS THAT DO NOT HAVE TORQUE CHART)

B. "C" FINISH - CLASS 1K (ISO 6 CLEANROOM COMPATIBLE FINISHES) - SKY WHITE POWDER COATED END FRAMES, GEARBOX PAINTED GLOSS WHITE EPOXY, NICKEL PLATED COMPONENTS (NO ZINC), STAINLESS STEEL FASTENERS AND MISC. HARDWARE OR VERY MINIMAL BLACK OXIDE FASTENERS. OPEN-ENDED TUBES NICKEL PLATED (EXCEPT FORKLIFT TUBES). KRYTOX GPL 207 LUBRICANT ON CASTER SWIVEL BEARINGS AND TRUNNION NEEDLE ROLLER BEARINGS.

IF REQUESTED BY CUSTOMER - ALL BLACK OXIDE FASTENERS SHOULD BE STRIPPED AND POST BAKED AT 375°F FOR 4 HOURS WITHIN 1 HR OF STRIPPING OF BLACK OXIDE TO PREVENT HYDROGEN EMBRITTLEMENT. AFTER STRIPPING, APPLY NEDOX NH1 COATING OF .0001 - .0002 THICKNESS AND POST BAKE AT 375°F FOR 4 HRS FOR HYDROGEN EMBRITTLEMENT RELIEF.

LOAD RATING: 3,200 LBS @ 3.75" MAX ECCENTRICITY (FOR 60:1 RATIO GEARBOX) CONSIDERING A SIMULTANEOUS 1/2G SIDE LOAD (WORST CASE DIRECTION) AND A 1G VERTICAL LOAD. SFy=3 & SFult=5.

a) MAX TORQUE ON 60:1 RATIO SR GEARBOX: 3.75" MAX CG OFFSET X 3,200 LB MAX PAYLOAD = 12,000 IN-LBS (2,000 IN-LBS MAX EASY CRANK)

b) MAX TORQUE ON 300:1 RATIO (DR3) GEARBOX: 3.75" MAX CG OFFSET X 3,200 LB MAX PAYLOAD = 12,000 IN-LBS (6,000 IN-LBS MAX EASY CRANK)

c) MAX TORQUE ON 600:1 RATIO (DR6) GEARBOX: 3.75" MAX CG OFFSET X 3,200 LB MAX PAYLOAD = 12,000 IN-LBS (12,000 IN-LBS MAX EASY CRANK)

WEIGHT IN TITLE BLOCK INCLUDES 3,200 LB PAYLOAD.

NOTES:

LATERAL TIPOVER FOR Ø6" STANDARD CASTER (SHOWN) WITH 3,200 LB PAYLOAD: $16.50 / 31.25 = .53G$

LATERAL TIPOVER FOR Ø8" C1 & C2 CASTERS WITH 3,200 LB PAYLOAD: $16.50 / 33.88 = .49G$

(NOTE: STABILITY WILL CHANGE DEPENDING ON "B" DISTANCE AND OPTIONS CHOSEN.

CONTACT FLOTRO IF YOU NEED TO KNOW STABILITY OF YOUR SPECIFIC CONFIGURATION)

PROPRIETARY
This Drawing is the property of FLOTRO, Inc. and is not to be used, copied or reproduced in any way other than for the particular purpose for which it is provided, and when said purpose has been fulfilled, it should be destroyed or returned to FLOTRO, Inc.

UNLESS OTHERWISE SPECIFIED DIMENSIONS ARE IN INCHES
LINEAR TOLERANCES: ±.03 XX
ANGULAR TOLERANCES: ±.5° XX
DO NOT SCALE DRAWING INTERPRET DIMENSIONING AND TOLERANCING PER ASME Y14.5-2018 INTERPRET DWG. PER ASME Y14.100

FLOTRO 2630 PROGRESS STREET VISTA, CALIFORNIA 92081 <http://www.flotron.com>

SFP-847

SCALE	SIZE	DRAWING NO.
1 : 8	D	8053-000PROP
WT: 4343.0 lbmass		Cad software: Inventor SHEET 1 OF 9

SFP-800 SERIES OPTIONS COMPATIBILITY MATRIX

		SIZE			FORKLIFT TUBES		JACKS		GEARBOX			CORDLESS HAND DRILL		INDEX PLATE			TOWING INTERFACE			SECONDARY AXIS OF ROTATION CRADLE			
		SFP-847	SFP-853	SFP-862	BLANK	F1	BLANK	J5	BLANK	DR3	DR6	BLANK	D	BLANK	IND15	INDS15	BLANK	T1	T2	T3	BLANK	SA1-SA8	
SIZE	SFP-847																					X	
	SFP-853																						
	SFP-862																						
FORKLIFT TUBES	BLANK - NO TUBES																						
	F1																				X (5)		
JACKS	BLANK - NO JACKS																						
	J5																				X (4)		
GEARBOX	BLANK - STANDARD									-		X										-	
	DR3											-										-	
	DR6											-											-
CORDLESS HAND DRILL	BLANK - NO DRILL																						-
	D								X	-					-	-							
INDEX PLATE	BLANK - NO INDEX																						
	IND15												-										
	INDS15												-										
TOWING INTERFACE	BLANK - NO TOW																						
	T1																						
	T2																						
	T3						X (5)		X (4)														
SECONDARY AXIS OF ROTATION CRADLE	BLANK - NO CRADLE																						
	SA1-SA8	X								-	-		-										
NOTES:		1. OPTIONS SHOWN AS X	ARE NOT COMPATIBLE WITH OTHER OPTIONS																				
		2. OPTIONS SHOWN AS -	ARE COMPATIBLE WITH OTHER OPTIONS BUT NOT RECOMMENDED. CONTACT FLOTRON FOR FURTHER DETAILS AND EXPLANATION OF CONCERNS/RISKS																				
		3. OPTIONS NOT SHOWN IN THIS MATRIX ARE COMPATIBLE WITH ALL OTHER OPTIONS																					
		4. JACKS WITH T3 OPTION ARE COMPATIBLE WITH SFP-862 ONLY (NOT COMPATIBLE WITH SFP-847 & SFP-853)																					
		5. TOWBAR (T3) OPTION WITH FORKLIFT TUBES (F1) COMPATIBLE WITH SFP-847 ONLY (NOT COMPATIBLE WITH SFP-853 & SFP-862)																					

This Drawing is the property of FLOTRON, Inc. and is not to be used, copied or reproduced in any way other than for the particular purpose for which it is provided, and when said purpose has been fulfilled, it should be destroyed or returned to FLOTRON, Inc.

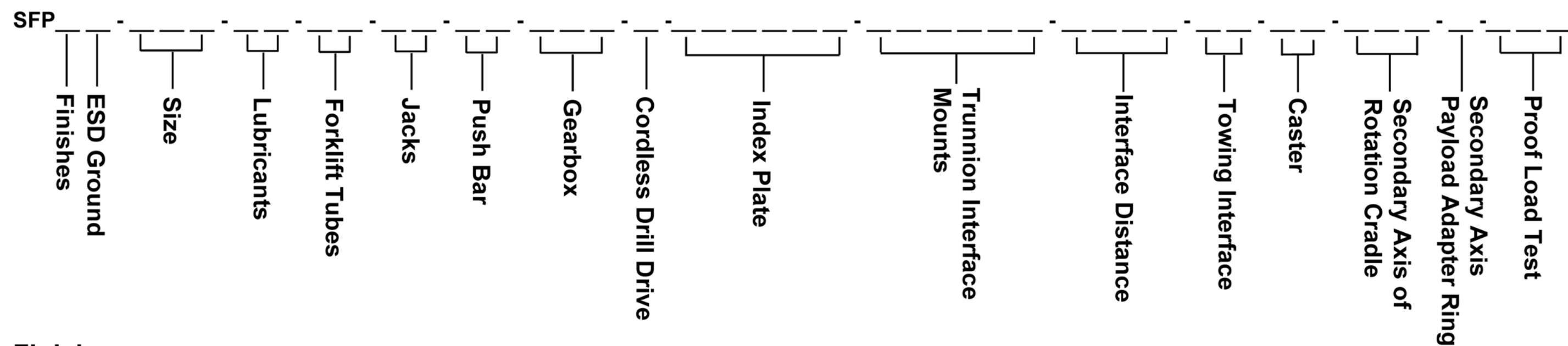

SFP-800 SERIES CREATING A MODEL NUMBER

Finishes

(blank)-Standard finishes (No Zinc)
C - - - - Clean room finishes (See proposal drawing for details)

ESD Ground

(blank) - No ESD ground
E - - - - - Ground lug and drag chain for use in EPA's

Size

847 - 47" Wide frame; 26"-32" max payload swing radius; 3,200 lb. capacity
853 - 53" Wide frame; 32"-42" max payload swing radius; 3,200 lb. capacity
862 - 62" Wide frame; 42"-54" max payload swing radius; 3,200 lb. capacity

Lubricants

(blank) - Standard lubricants
L1 - - - - - Jacks, trunnion, & caster swivel bearings lubricated with Krytox GPL 207
L2 - - - - - Jacks, trunnion & caster swivel bearings lubricated with Braycote 601EF
NOTE: "C" finish includes L1 Lubricants except in jack screw threads

Forklift Tubes

(blank) - No Forklift Tubes
F1 - - - - - Frame Mounted Forklift Tubes (Not available for "B" Distances over 150"). Inside of tubes not fully plated (Even for "C" finish).

Jacks

(blank) – No jacks provided
J2 - - - - - Jacks with crank handles opposite of mounting plate
J3 - - - - - Jacks with crank handles pointing towards ends of fixture
J4 - - - - - Jacks with crank handles pointing towards center of fixture

Push Bar

(blank) - No push bar
P1 - - - - - Gearbox mounted push bar for 847 & 853.
End frame mounted push bar for 862.

Gearbox

(blank) - Standard 60:1 Low Backlash Gearbox
DR3 - - - - - 300:1 Low Backlash, Stairstep Resistant Gearbox.
Recommended for torques higher than 2,000 in-lbs
DR6 - - - - - 600:1 Low Backlash, Stairstep Resistant Gearbox.
Recommended for torques higher than 6,000 in-lbs
Must select when using drill drive "D" option.

Cordless Drill Drive Input

(blank) – No hand drill
D - - - - - Battery powered hand drill mounted to gearbox input shaft
(Must select DR6 gearbox option)

Index Plate

(blank) - - No index plate
IND15 - - - 15° index plate
INDS15 - 15° index plate with index stops
NOTE: Special index plate hole spacing available upon request.

Proof Load Test

(blank) - No proof load test
PLT - - - - Standard proof load test (includes deliverable report)

Secondary Axis Payload Adapter Ring

(blank) – No adapter ring for secondary axis of rotation.
Standard SA interface comes with 36X ¼-28 threaded holes on a Ø24" bolt circle (ESPA Grande)
R - - - - - Adapter ring to convert SA interface holes to 36X Ø.281 thru holes on a Ø24" bolt circle (ESPA Grande)

Secondary Axis of Rotation Cradle

(blank) - No secondary axis of rotation
SA1 - - - - Secondary axis of rotation (Bolt Position 1)
SA2 - - - - Secondary axis of rotation (Bolt Position 2)
SA3 - - - - Secondary axis of rotation (Bolt Position 3)
SA4 - - - - Secondary axis of rotation (Bolt Position 4)
SA5 - - - - Secondary axis of rotation (Bolt Position 5)
SA6 - - - - Secondary axis of rotation (Bolt Position 6)
SA7 - - - - Secondary axis of rotation (Bolt Position 7)
SA8 - - - - Secondary axis of rotation (Bolt Position 8)
NOTE: NOT COMPATIBLE WITH SIZE 847.
See proposal drawing to determine correct bolt position. Bolt positions can be changed in the field, but bolt position selected will be the bolt position fixture is shipped with. Must select B120 interface distance when specifying standard length cradle. Special length cradles available upon request in increments of 20". To get most capability out of SA option and for best operator experience, "DR6" gearbox with drill drive input ("D" Option) is highly recommended. Option reduces load capacity to 2,500 lbs cantilevered 30" max from interface.

Caster

(blank) - Standard Ø6" nylon casters with brakes & swivel locks (no steering bars)
C1 - - - - - Ø8" nylon casters with brakes & swivel locks (no steering bars)
C2 - - - - - Ø8" poly. casters with steering bars, brakes, and swivel locks

Towing Interface

(blank) - No towing interface
T1 - - - - - Removable lunette ring towing interface (attaches to main beam)
T2 - - - - - Removable ball coupler towing interface (attaches to main beam)
T3 - - - - - Removable tow bar (attaches to end frames)

Interface Distance

B"XXX" - Main Beam length where "XXX"= length in inches between trunnion interface mounts. (1" increments within the following range)

MODEL	MIN	MAX
SFP-847	25"	280"
SFP-853	42"	280"
SFP-862	55"	280"

Trunnion Interface Mounts

P12 - - - - - 9" x 12" mounting plate with 8 thru holes
P12/A30 - - P12 (8 bolts 8" x 12") mounting plate and standard 30" long angle (no mounting holes) bolted to the P12.
P12/B30 - - P12 (8 bolts 8" x 12") mounting plate and 30" long angle (with standard mounting hole pattern) bolted to the P12.

NOTE: Special interface angle lengths available upon request

Example:

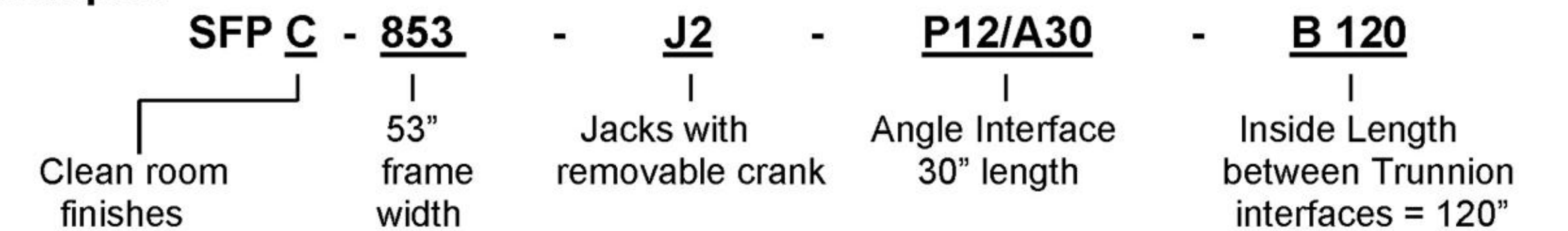

This Drawing is the property of FLOTRON, Inc. and is not to be used, copied or reproduced in any way other than for the particular purpose for which it is provided, and when said purpose has been fulfilled, it should be destroyed or returned to FLOTRON, Inc.

		2630 PROGRESS STREET VISTA, CALIFORNIA 92081 http://www.flotron.com	
		SCALE 1 : 8	DRAWING NO. 8053-000PROP
SHEET			3 OF 9

ESD GROUND (E)

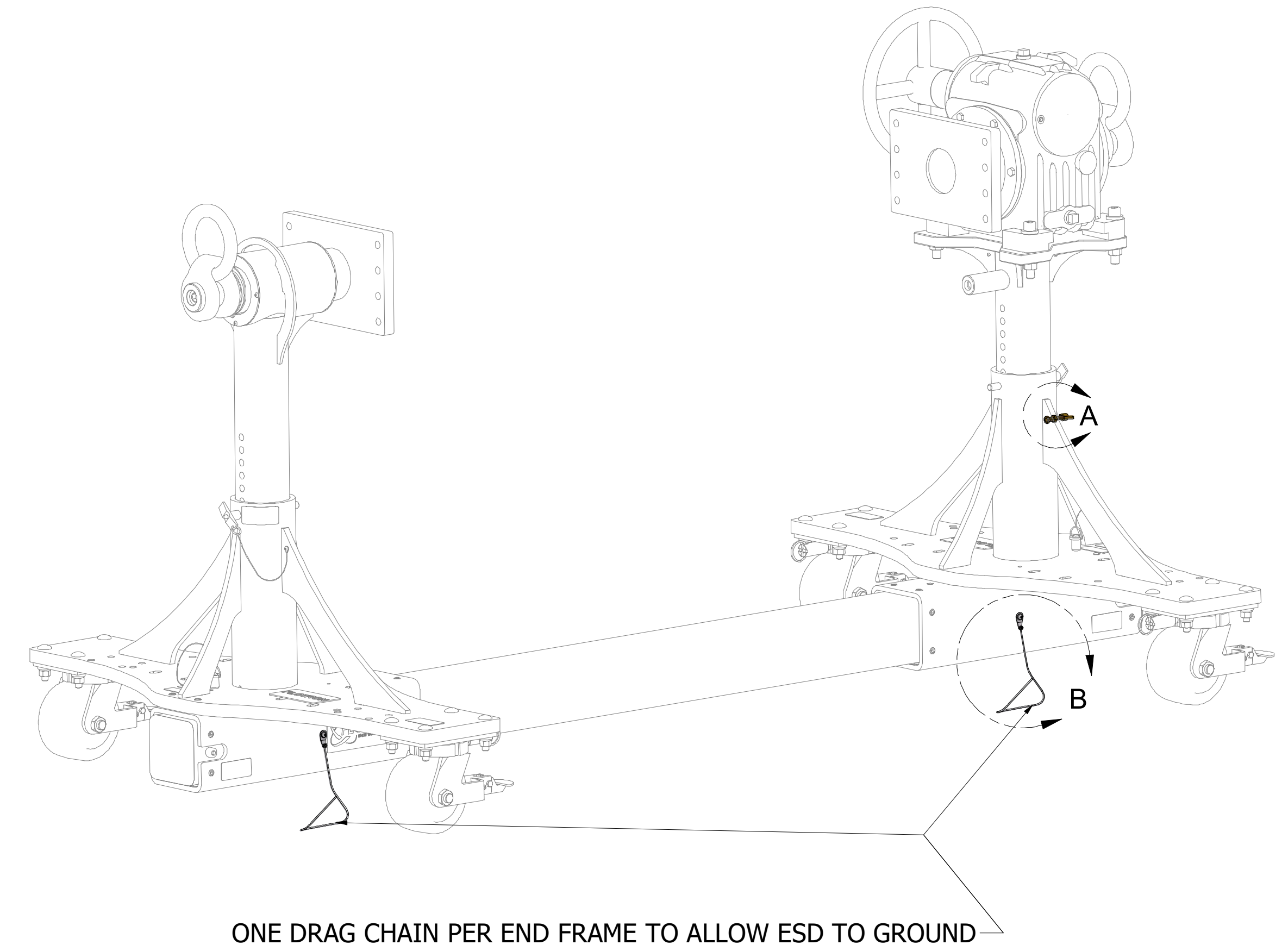
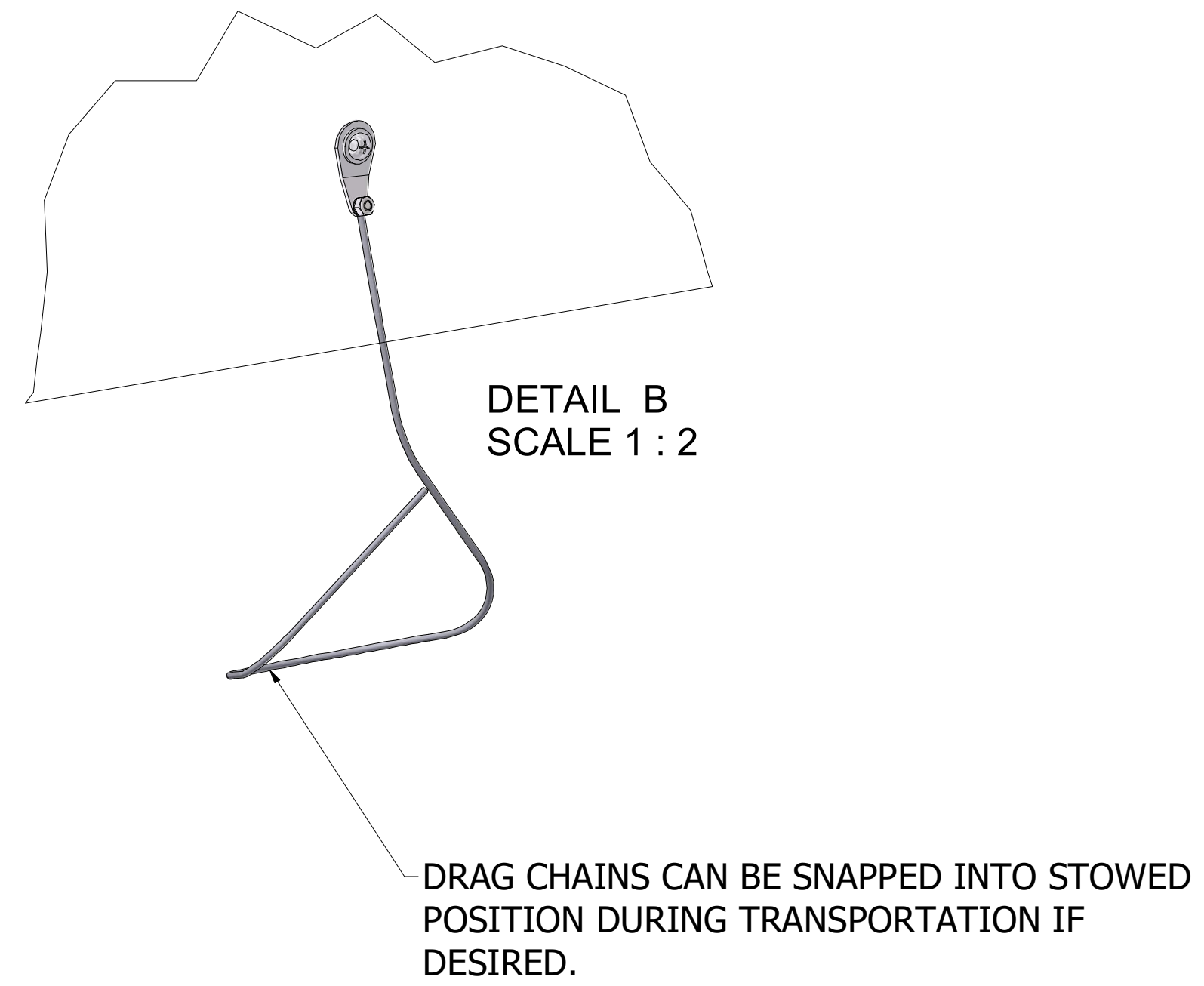
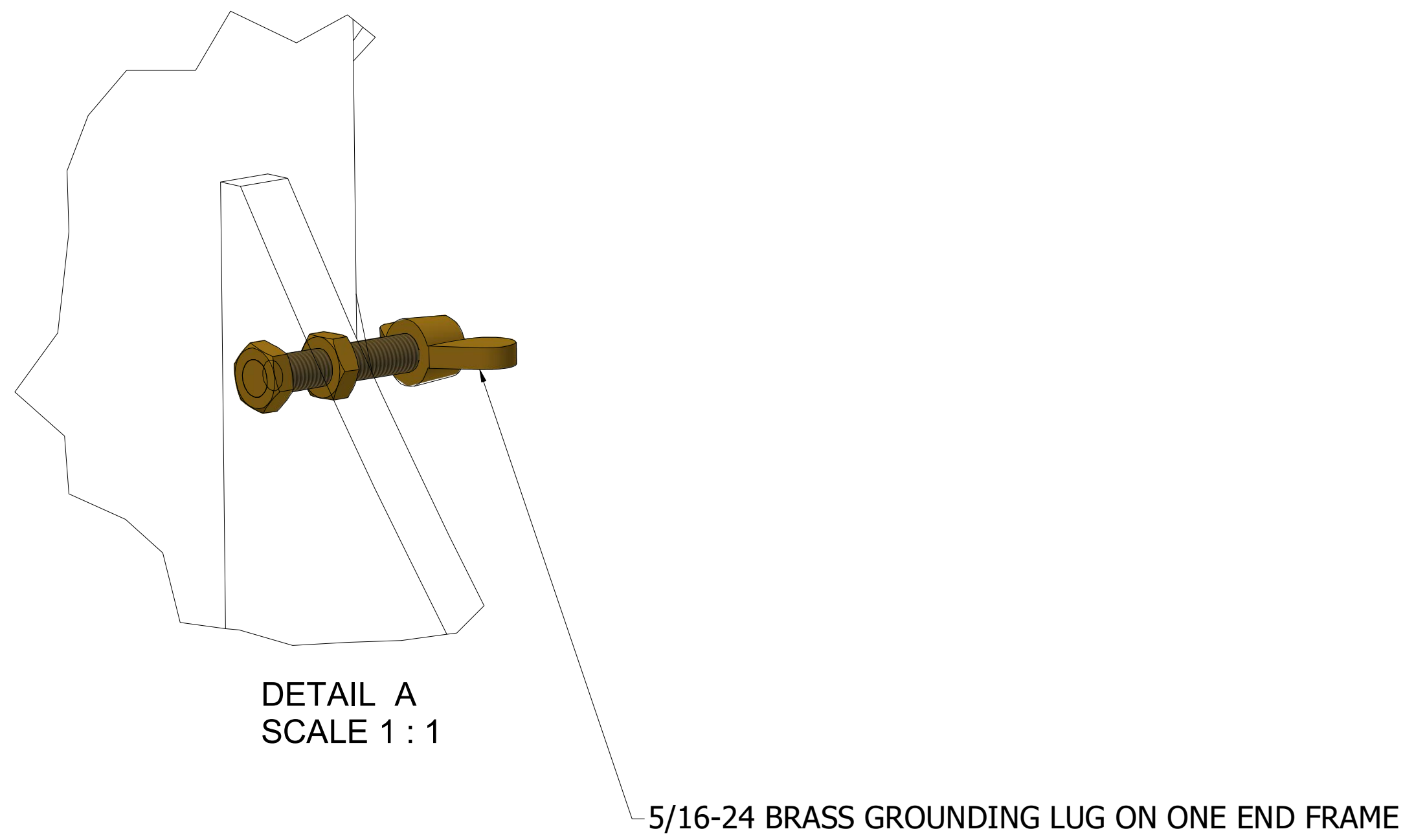

FRAME MOUNTED FORKLIFT TUBE KIT (F1)

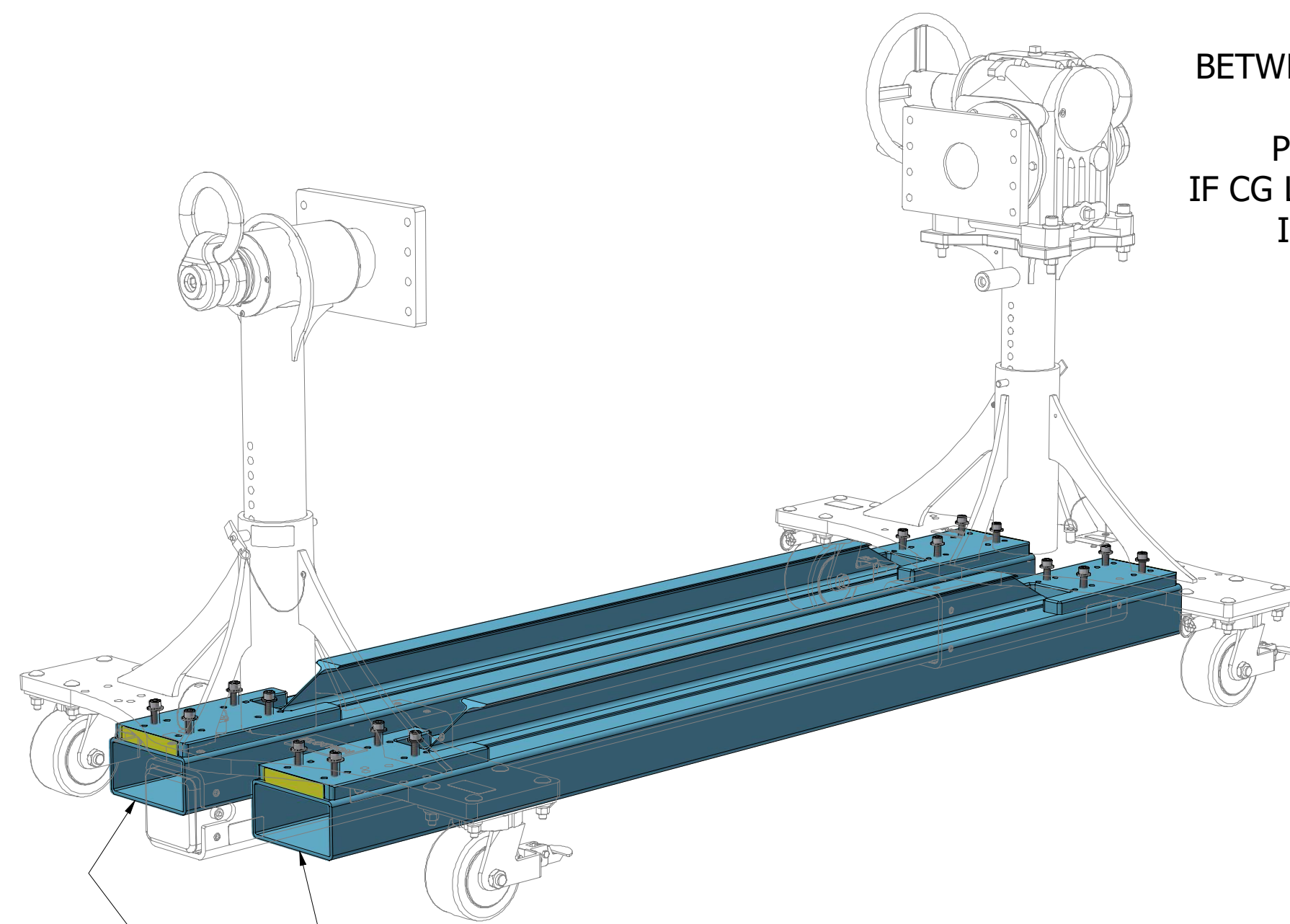

FORKLIFT FORKS SHOULD EXTEND ALL THE WAY THROUGH THE FORKLIFT TUBES IF THE PAYLOAD IS INTEGRATED AND AT LEAST A FOOT PAST THE CG OF THE FIXTURE IF LIFTING AN EMPTY FIXTURE.

FOR TYPICAL CONFIGURATION, EMPTY FIXTURE CG IS NEAR MID DISTANCE BETWEEN INTERFACES AND SLIGHTLY BIASED TOWARDS GEARBOX SIDE. EXACT CG POSITION DEPENDS ON CONFIGURATION. IF CG LOCATION OF SPECIFIC CONFIGURATION IS REQUIRED, CONTACT FLOTRON SALES.

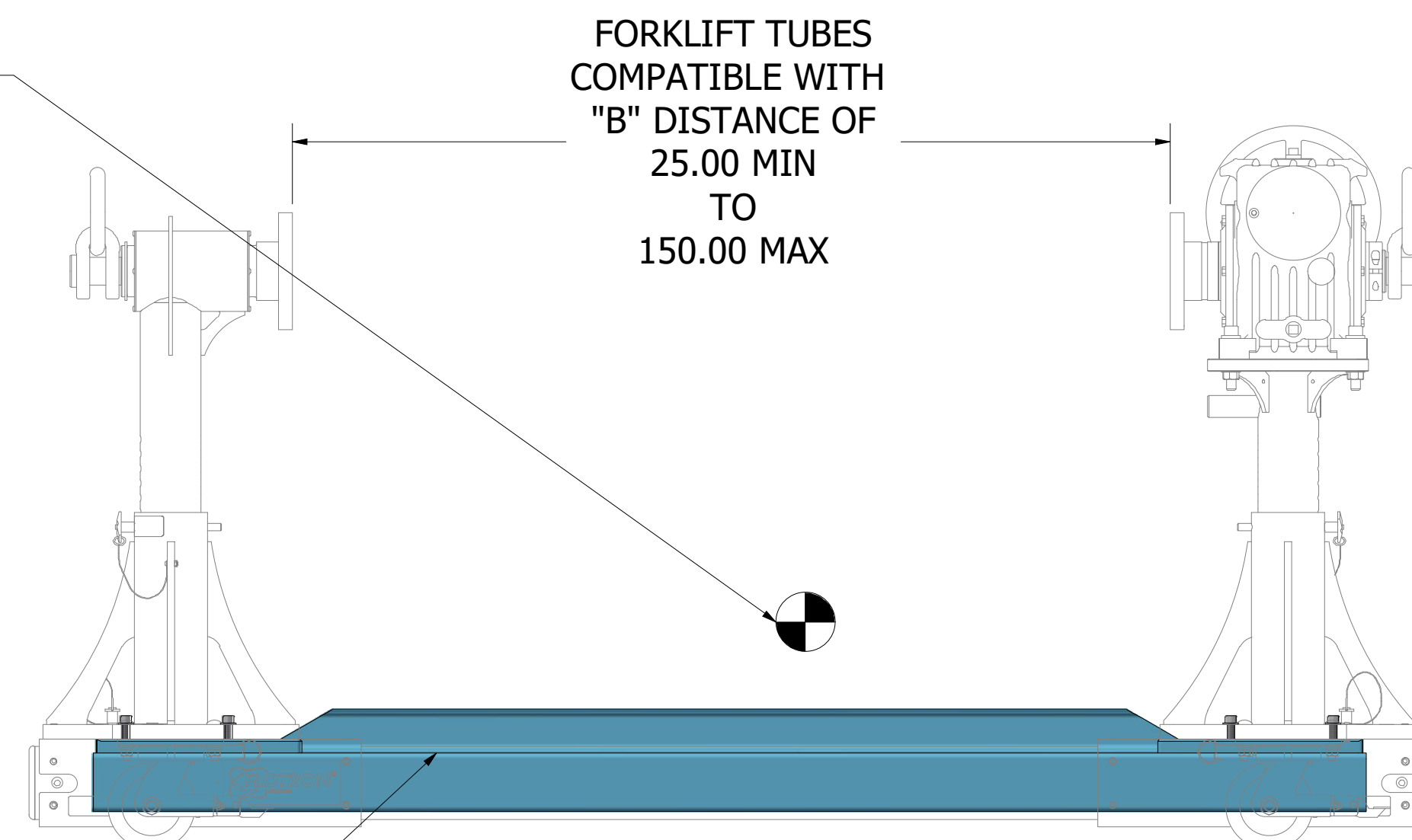

FORKLIFT TUBES CAN BE ADJUSTED +/- 1" FROM NOMINAL POSITION. AN ADDITIONAL +/- .5" FLOAT IN NON-GEARBOX SIDE TRUNNION CAN BE USED FOR FINE "B" DISTANCE ADJUSTMENT. TO ADJUST, FORKLIFTS MUST BE REMOVED AND ALTERNATE BOLT PATTERN USED ON FORKLIFT TUBE MOUNTING PLATE.

LUBRICATE 1/2-13 SS SHCS WITH KRYTOX GPL-207 AND TORQUE TO 28-33 FT-LBS

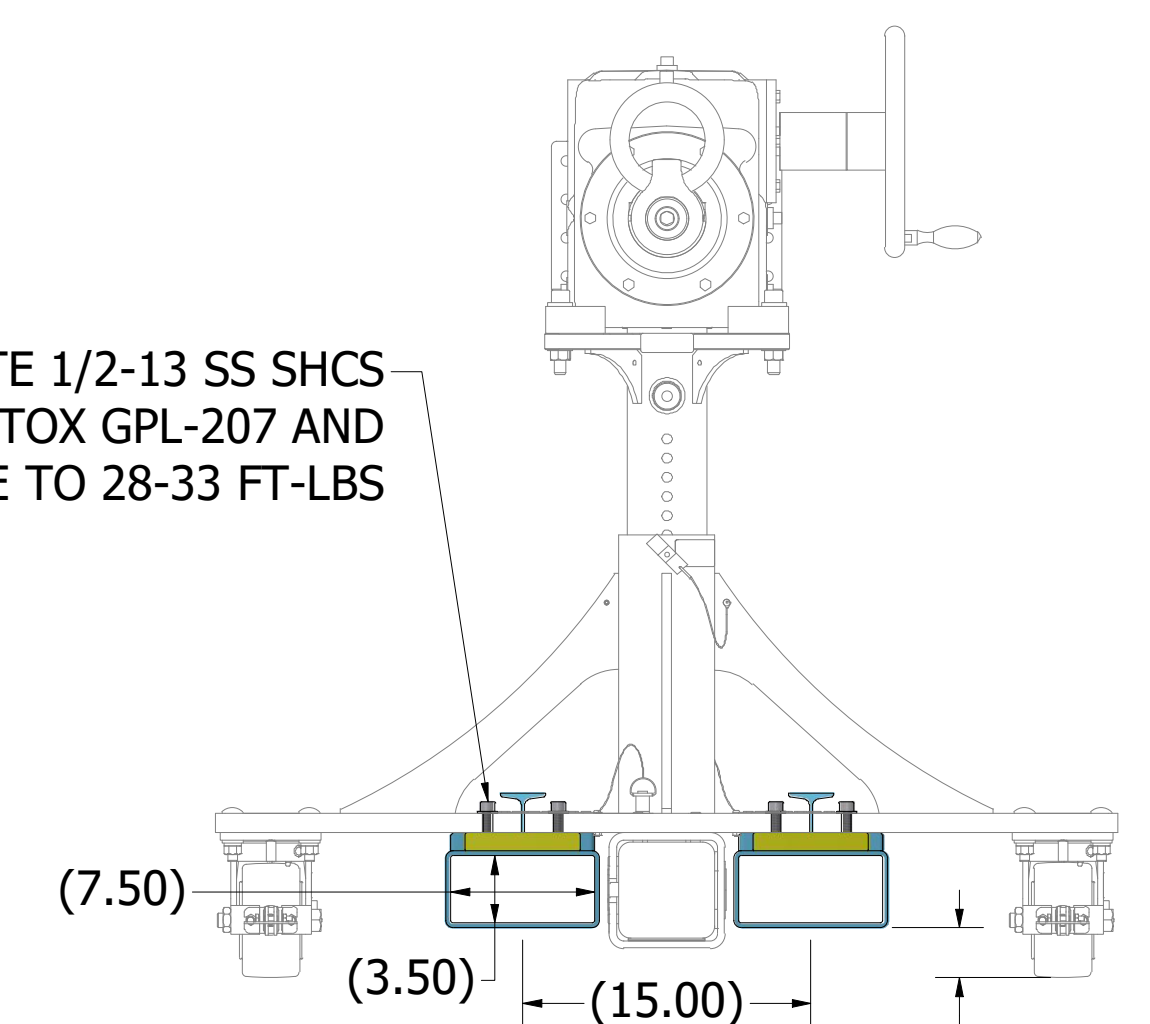

This Drawing is the property of FLOTRON, Inc. and is not to be used, copied or reproduced in any way other than for the particular purpose for which it is provided, and when said purpose has been fulfilled, it should be destroyed or returned to FLOTRON, Inc.

GEARBOX OPTIONS FOR HAND CRANK

(STANDARD) GEARBOX OPTION (60:1)

NON-BACKDRIVING 60:1 RATIO SINGLE STAGE WORM GEAR DRIVE.

STANDARD GEARBOX TORQUE CAPACITY: 12,000 IN-LBS
STANDARD GEARBOX MAX EASY CRANK TORQUE: 2,000 IN-LBS
 (EASY CRANK IS DEFINED AS A 12 LB INPUT FORCE ON THE CRANK HANDLE)

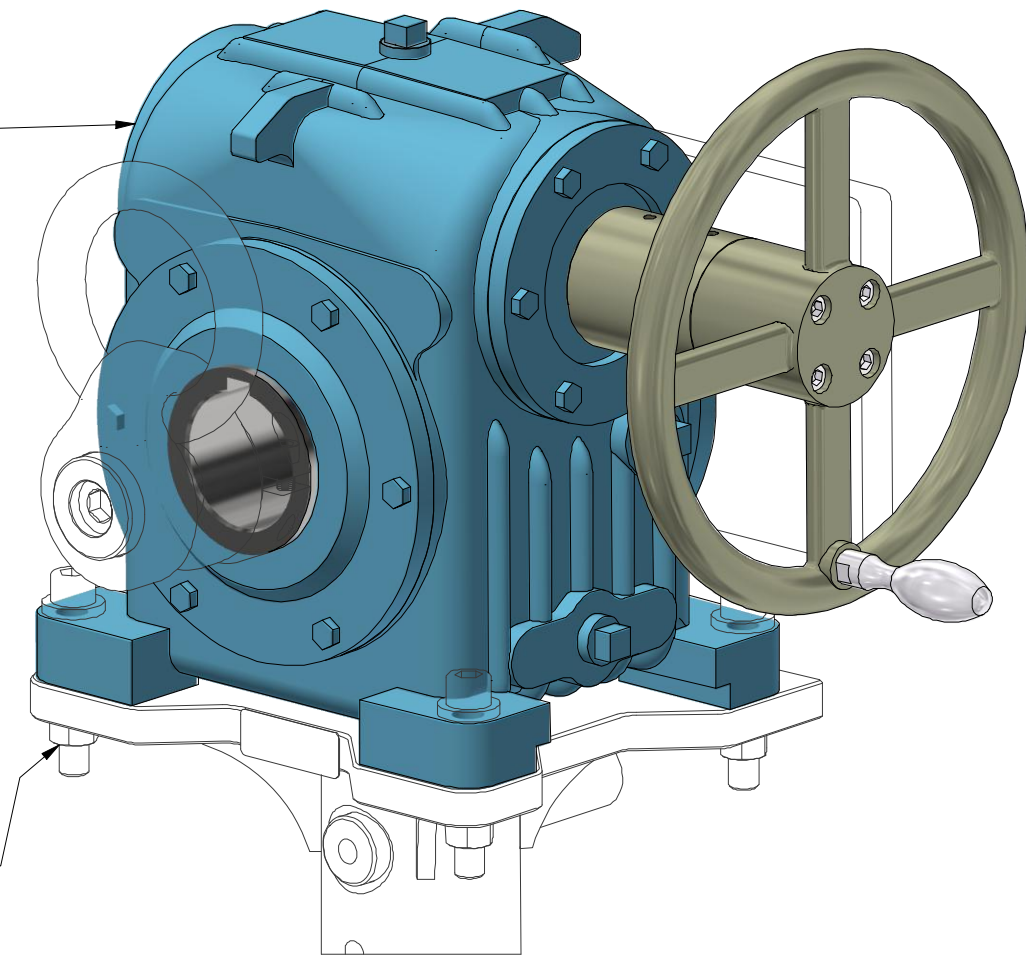

LUBRICATE WITH LOCTITE 242 (BLUE) AND TORQUE 1/2-13 FASTENERS TO 66-75 FT-LB

(DR3) GEARBOX OPTION (300:1) FOR HIGH ECCENTRICITY HAND CRANK APPLICATION

NON-BACKDRIVING WITH 300:1 RATIO DUAL STAGE WORM GEAR DRIVE.

DR3 GEARBOX TORQUE CAPACITY: 12,000 IN-LBS
DR3 GEARBOX MAX EASY CRANK TORQUE: 6,000 IN-LBS
 (EASY CRANK IS DEFINED AS A 12 LB INPUT FORCE ON THE CRANK HANDLE)

FLYWHEEL COMES STANDARD WITH 300:1 RATIO GEARBOX TO PREVENT STAIR-STEPPING (STICK-SLIP) IN GEARBOX FOR HIGH INERTIA PAYLOADS.

LUBRICATE WITH LOCTITE 242 (BLUE) AND TORQUE 1/2-13 FASTENERS TO 66-75 FT-LB

SET CLUTCH TO 250 IN-LBS FOR **DR3** (300:1) RATIO GEARBOX PRIOR TO ASSEMBLY

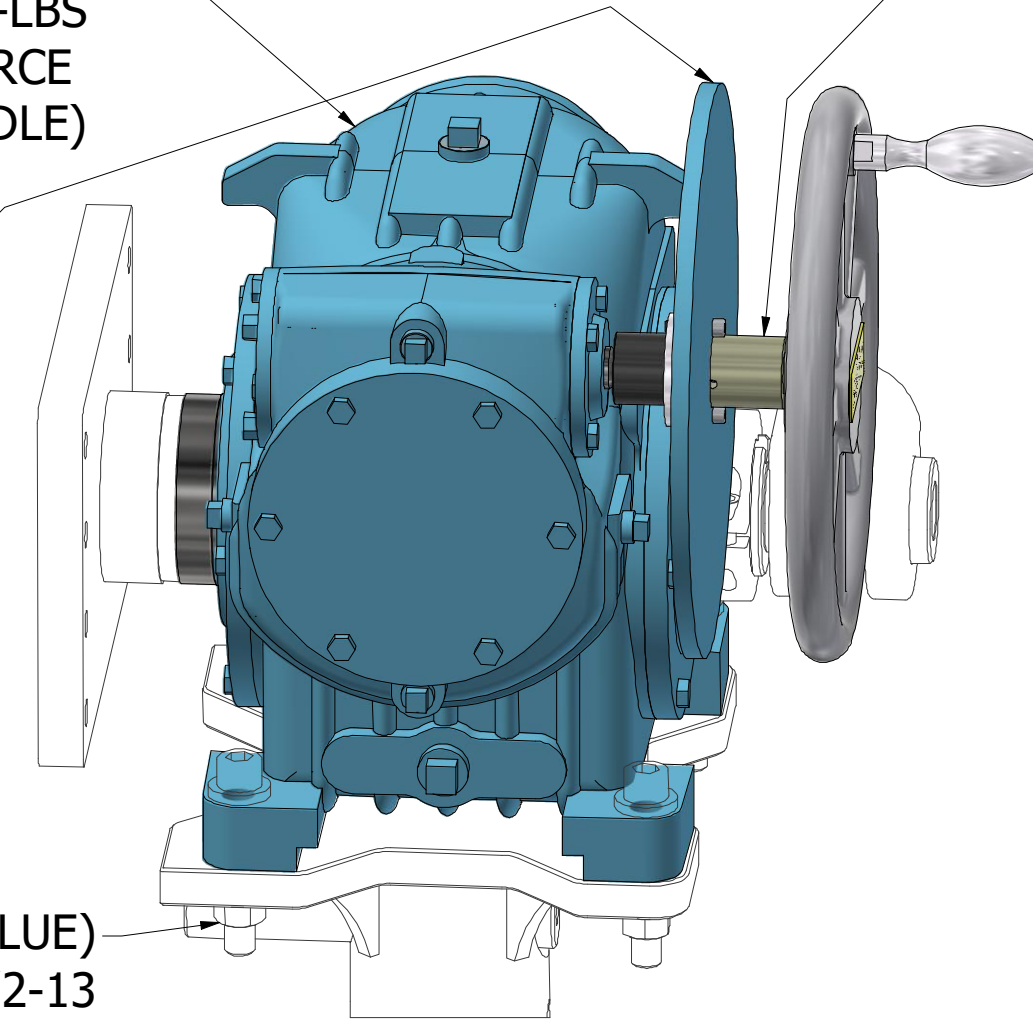

DRILL DRIVE OPTION (D) WITH (DR6) GEARBOX

WHEN **D** OPTION IS CHOSEN, **DR6** GEARBOX WILL HAVE A 600:1 RATIO. DRILL MAX RPM IS 300 RESULTING IN A MAX OUTPUT PAYLOAD ROTATION OF .5 RPM. WITH **D** OPTION, FULL GEARBOX TORQUE CAPACITY CAN BE USED. COMES STANDARD WITH CLUTCH BETWEEN THE GEARBOX AND HAND CRANK TO PREVENT OVER-TORQUE OF GEARBOX IN CASE INDEX PIN WAS NOT REMOVED BEFORE ROTATION OR PAYLOAD ECCENTRICITY IS TOO HIGH.

SET CLUTCH TO 125 IN-LBS FOR **DR6** (600:1) RATIO GEARBOX PRIOR TO ASSEMBLY

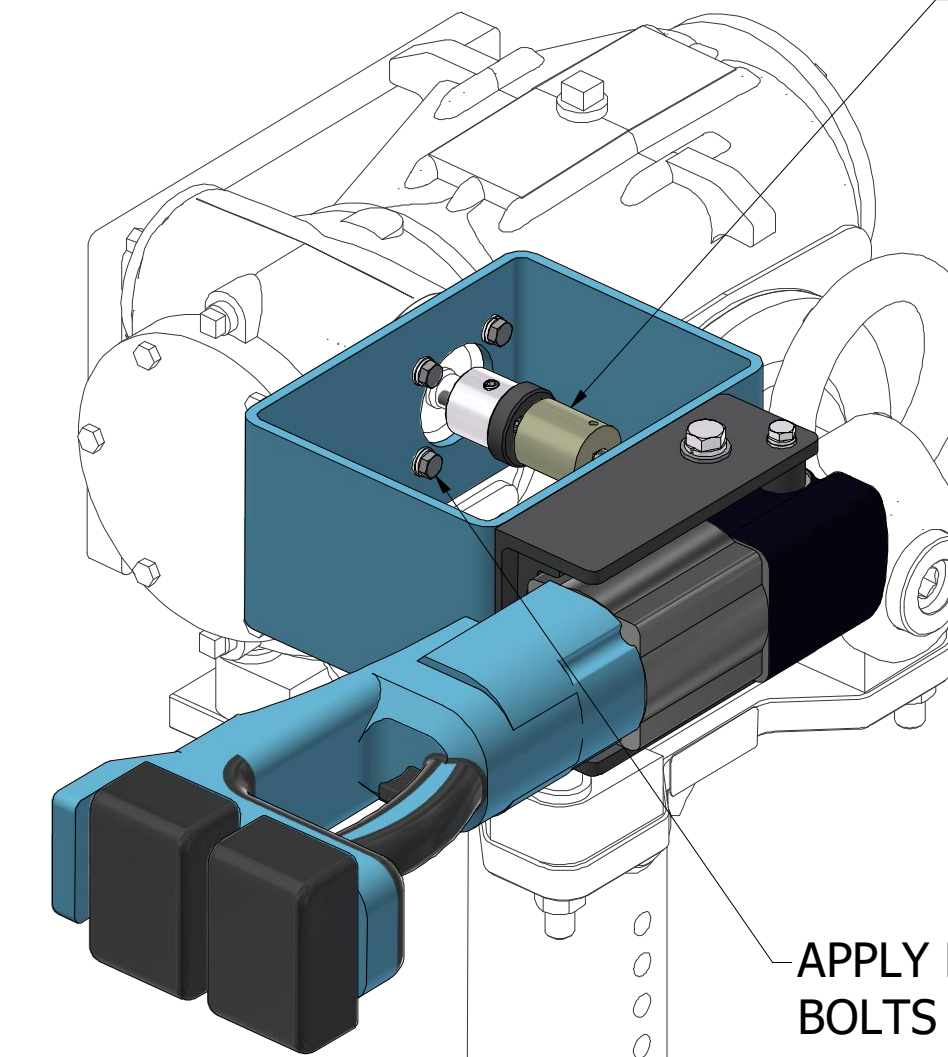

APPLY LOCTITE 271 RED TO 5/16-24 MOUNTING BOLTS AND TORQUE TO 8-9 FT-LBS

(IND(S)15) INDEX PLATE WITH OPTIONAL STOPS (S)

(PART OF THE P12 INTERFACE WELDMENT)

INDEX STOPS REQUIRED ONLY IF (S) IS IN THE IND(S)15 CONFIGURATION. LUBRICATE 1/2-13 SS BOLTS WITH KRYTOX GPL-207 AND TORQUE TO 29-33 FT-LBS.

INDEX PLATE INCREASES OAH OF FIXTURE BY " FOR **DR3** & **DR6** OPTIONS 1.61

MAKE SURE COLLAR AND SHAFT WELDMENT ARE BOTH PUSHED TIGHTLY AGAINST GEARBOX BEFORE TIGHTENING COLLAR. TORQUE COLLAR TO 29-34 FT-LBS (DRY)

CAUTION: INDEX PIN MUST BE REMOVED PRIOR TO ROTATION. FAILURE TO REMOVE PIN COULD DAMAGE INDEX PLATE OR GEARBOX.

INDEX STOPS CAN BE REMOVED BY CUSTOMER AND PLACED ANYWHERE ON INDEX PLATE TO LIMIT ROTATION TO DESIRED RANGE

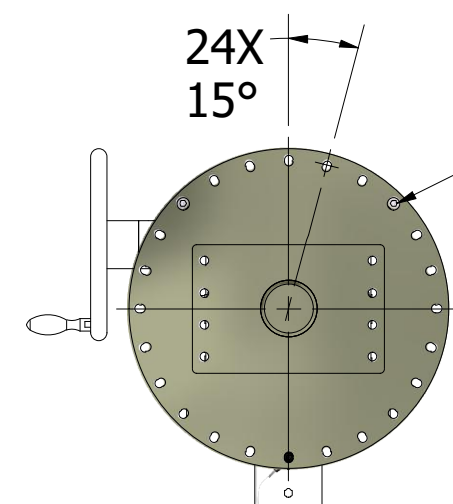
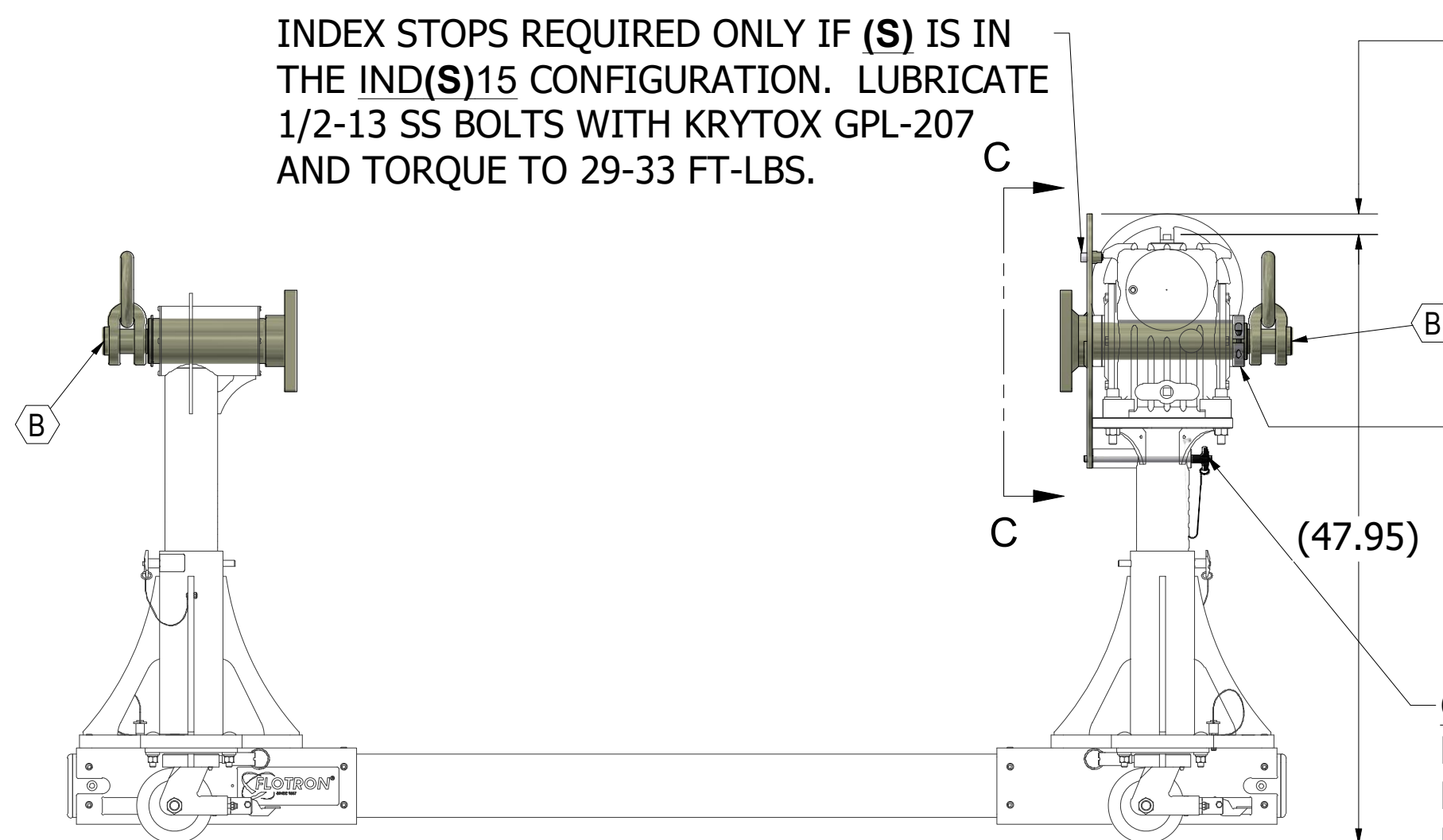

SECTION C-C
SCALE 1 : 12

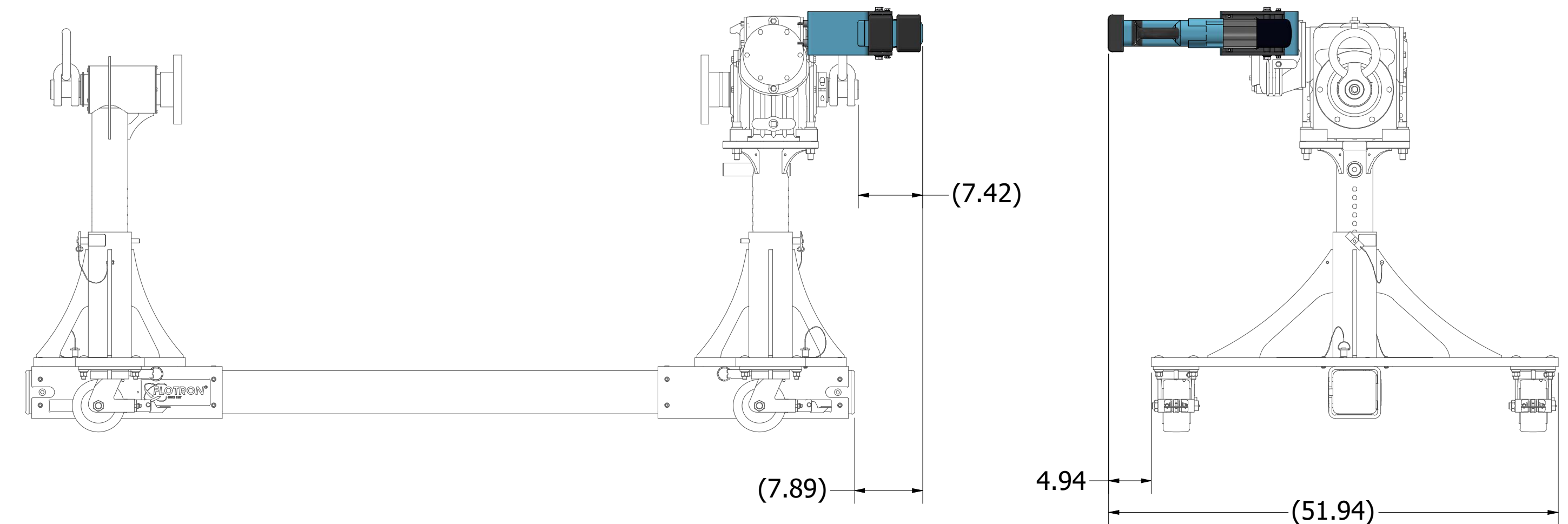

NOTE: DRILL DRIVE INCREASES OVERALL LENGTH AND WIDTH OF FIXTURE BY DIMENSIONS INDICATED

This Drawing is the property of FLOTRON, Inc. and is not to be used, copied or reproduced in any way other than for the particular purpose for which it is provided, and when said purpose has been fulfilled, it should be destroyed or returned to FLOTRON, Inc.

		2630 PROGRESS STREET VISTA, CALIFORNIA 92081 http://www.flotron.com	
SCALE	1 : 8	SIZE	D
		DRAWING NO.	8053-000PROP
			SHEET 5 OF 9

STABILIZING/LEVELING JACKS (J2, J3, J4)

FOR "STANDARD" AND "C" FINISH LUBRICATE SCREW THREADS WITH SYNCO-SUPER LUBE SYNTHETIC GREASE WITH SYNCOLON (PTFE).
 FOR "L1" FINISH, LUBRICATE SCREW THREADS WITH KRYTOX GPL 207 GREASE.
 FOR "L2" FINISH, LUBRICATE SCREW THREADS WITH BRAYCOTE 601 EF.

LUBRICATE WITH KRYTOX GPL 207 (EXCEPT FOR L2 OPTION) & TORQUE 1/2-13 BOLTS TO 70-80 FT-LB

JACK AND BRACKET MOUNTING PLATE BOTTOMS SHOULD BE MOUNTED FLUSH FOR C1 & C2 CASTER OPTIONS

2.19 MAX RETRACTED WITH Ø6" STANDARD CASTERS
 (3.32 MAX RETRACTED WITH Ø8" C1 CASTERS)

3.81 MAX LIFT WITH Ø6" STANDARD CASTERS
 (2.68 MAX LIFT WITH Ø8" C1 CASTERS)

(67.94) OAW WITH JACKS IN J3 & J4 ORIENTATIONS

(79.98) OAW WITH JACKS IN J2 ORIENTATION

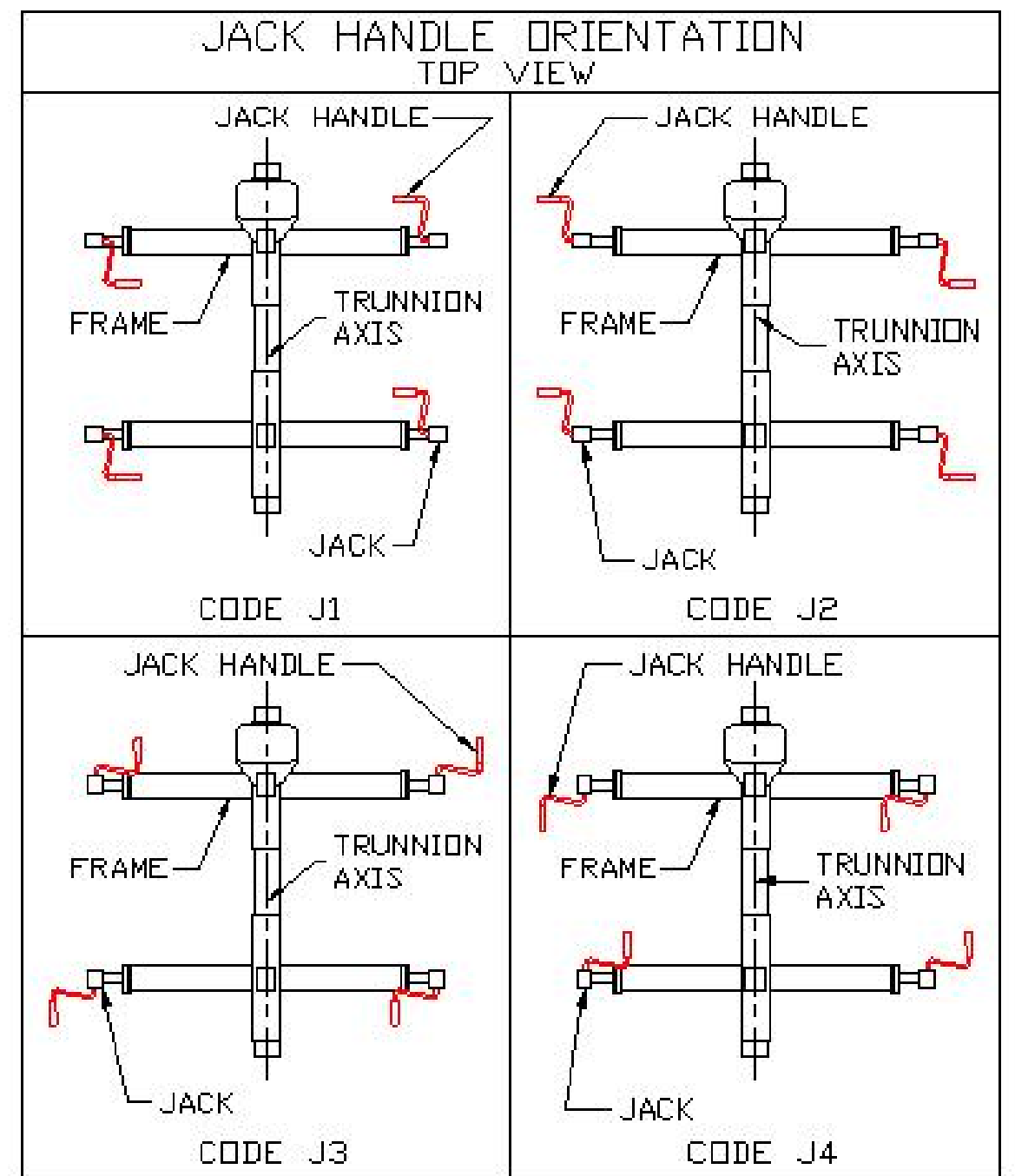

GEARBOX MOUNTED PUSH BAR (P1)

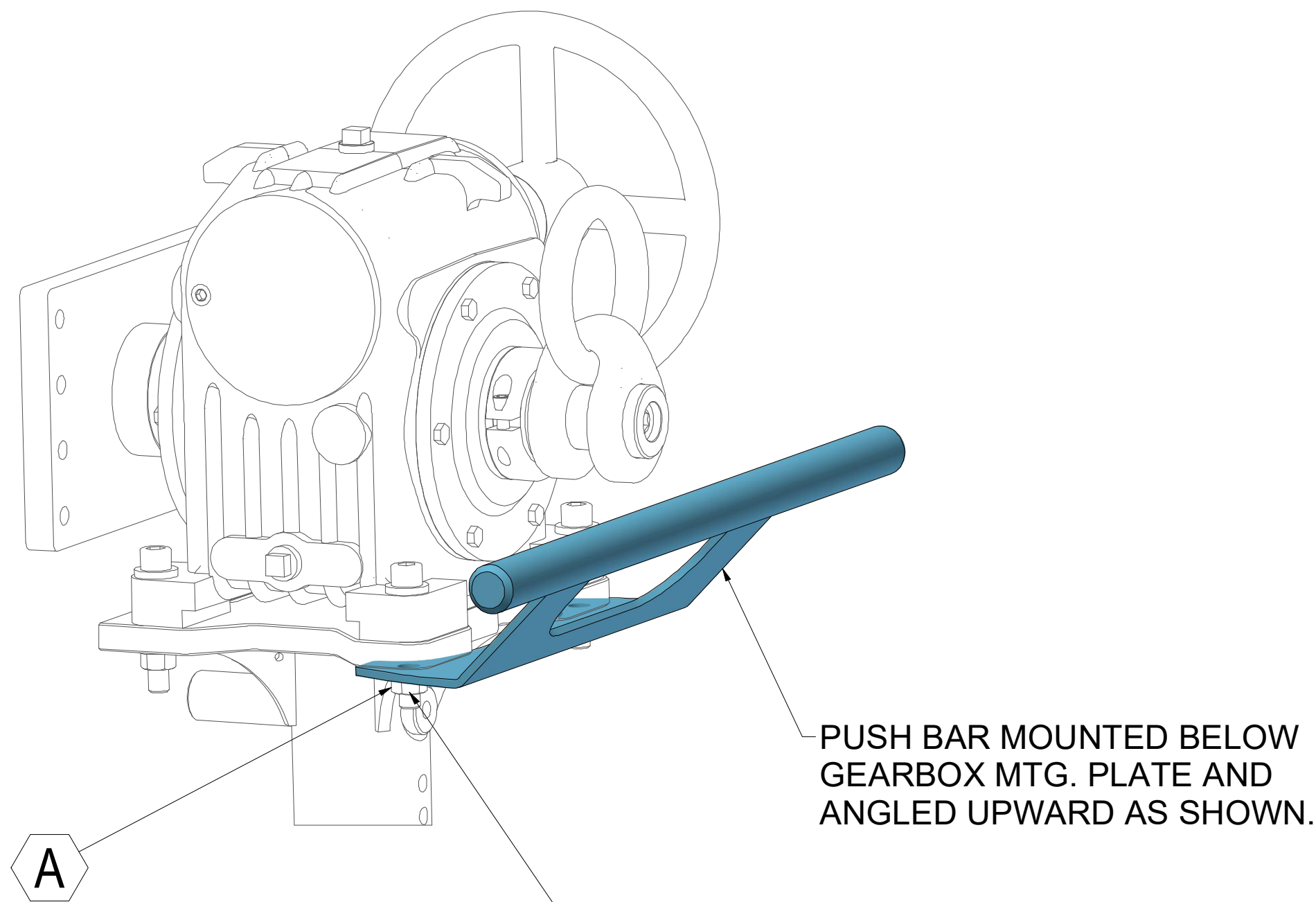

PUSH BAR MOUNTED BELOW GEARBOX MTG. PLATE AND ANGLED UPWARD AS SHOWN.

USE SAME HARDWARE THAT COMES WITH BASIC ASSEMBLY KIT

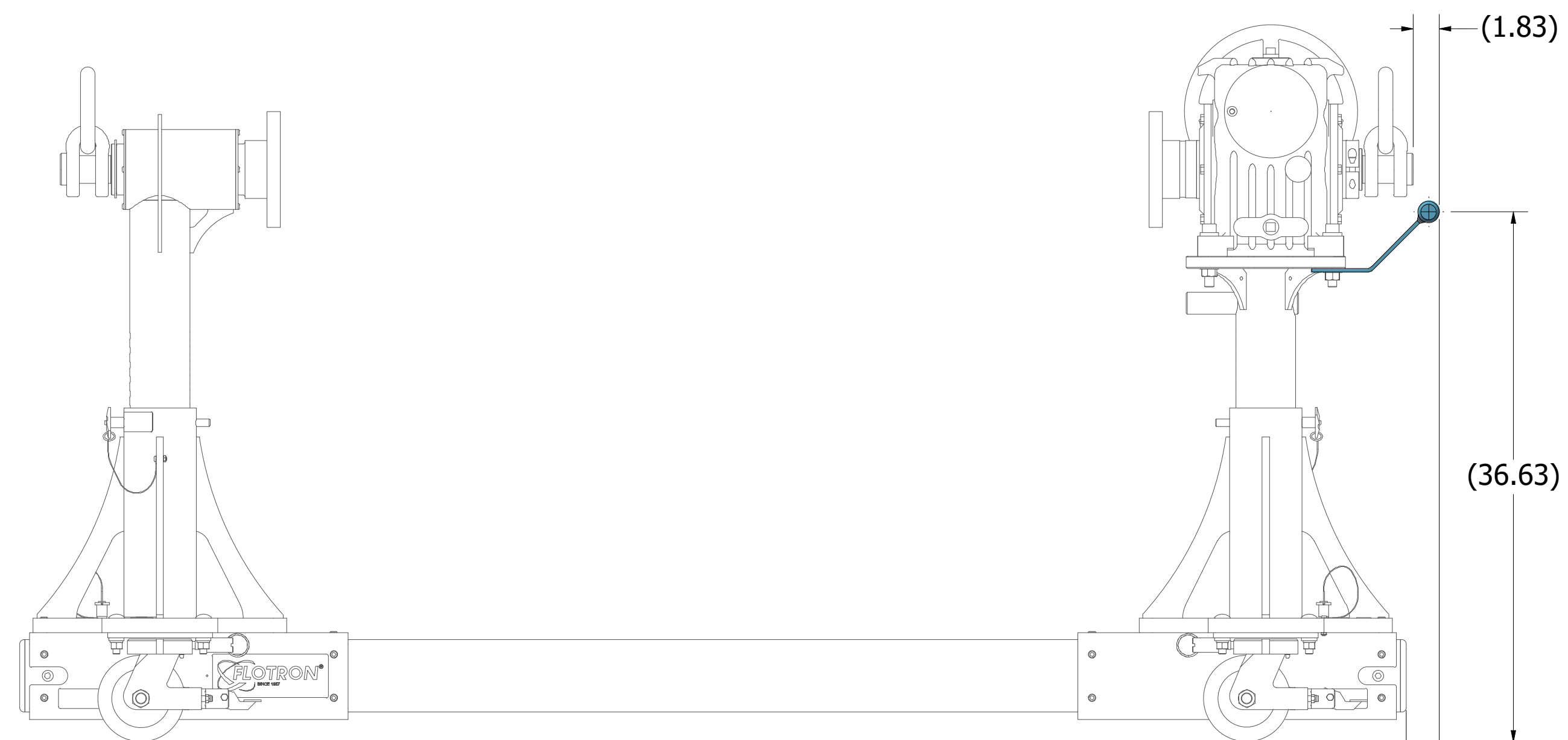

NOTE: PUSH HANDLE INCREASES OVERALL LENGTH OF FIXTURE BY DIMENSIONS INDICATED

This Drawing is the property of FLOTRON, Inc. and is not to be used, copied or reproduced in any way other than for the particular purpose for which it is provided, and when said purpose has been fulfilled, it should be destroyed or returned to FLOTRON, Inc.

CASTER OPTIONS

Ø6" CASTERS (STANDARD)

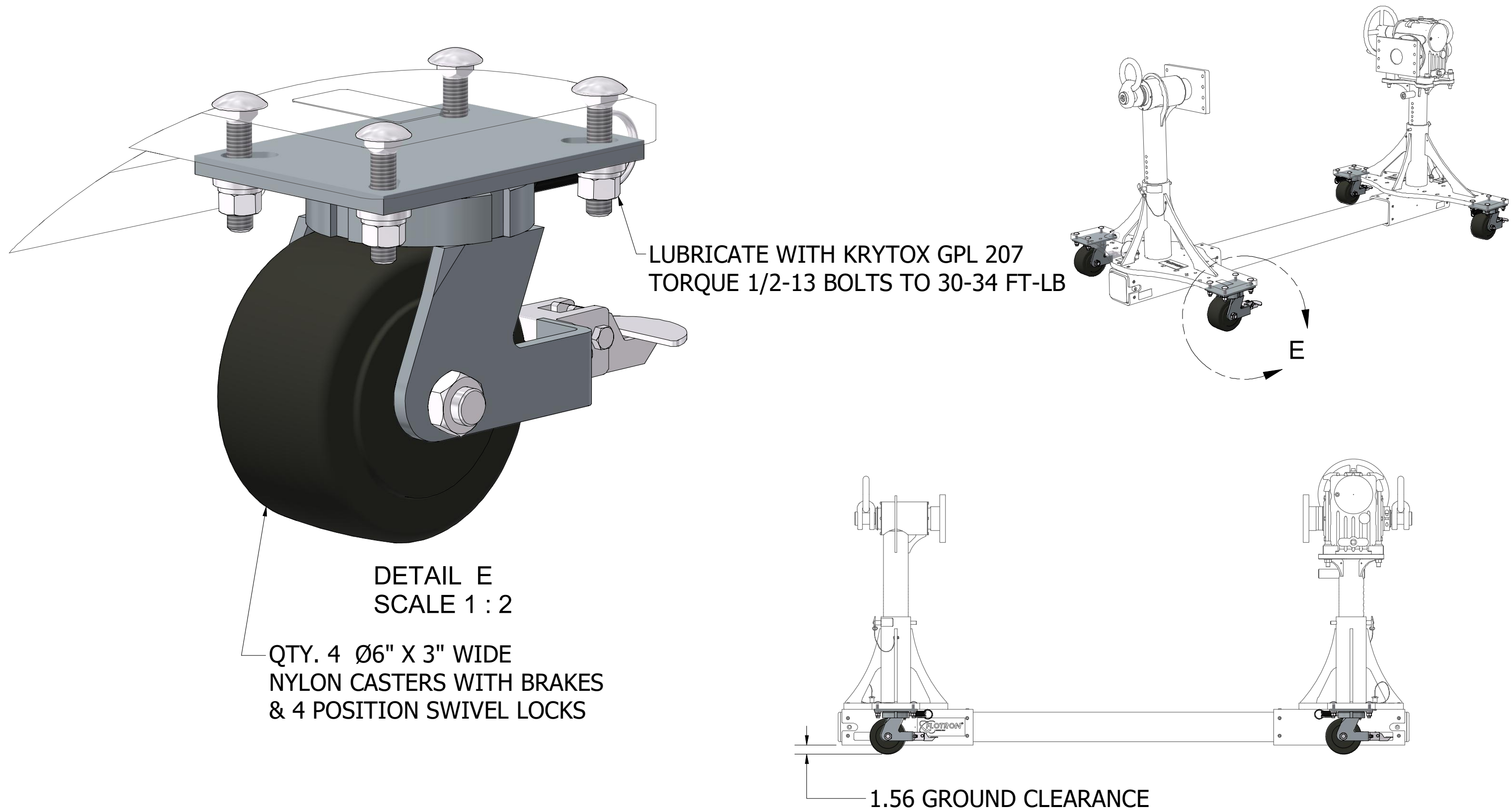

Ø8" CASTERS (C1)

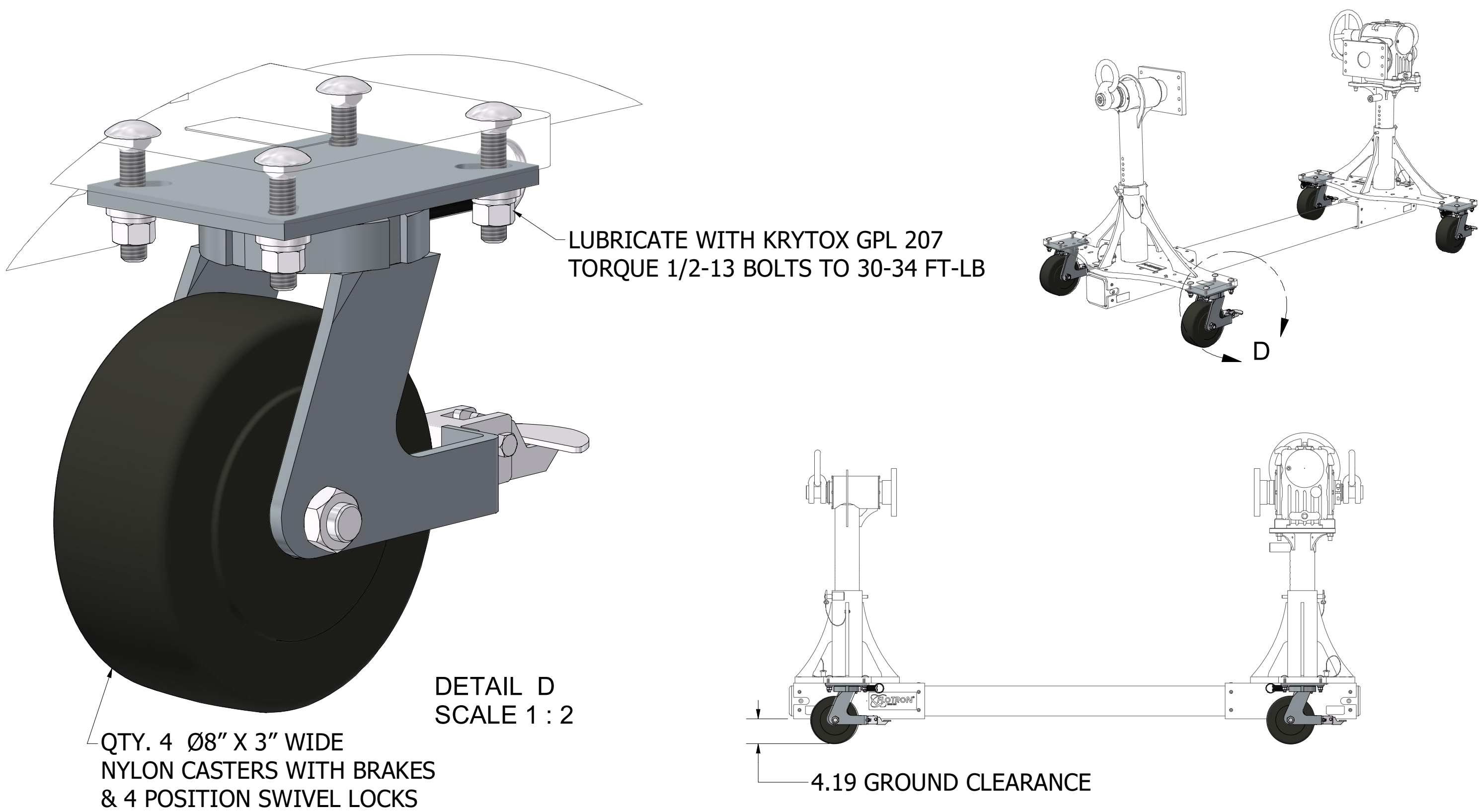

Ø8" POLYURETHANE CASTERS WITH STEERING TUBES/BARS (C2)

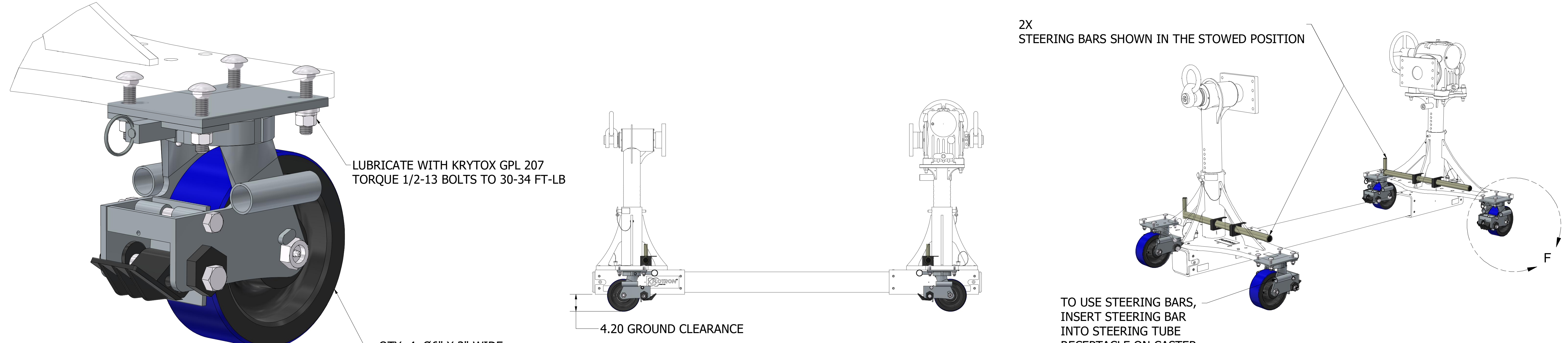

This Drawing is the property of FLOTRON, Inc. and is not to be used, copied or reproduced in any way other than for the particular purpose for which it is provided, and when said purpose has been fulfilled, it should be destroyed or returned to FLOTRON, Inc.

		2630 PROGRESS STREET VISTA, CALIFORNIA 92081 http://www.flotron.com	
		SCALE 1 : 8	SIZE D
		DRAWING NO. 8053-000PROP	
		SHEET 7 OF 9	

TRUNNION INTERFACE MOUNT OPTIONS

P12 PAYLOAD INTERFACE

(TYPICAL BOTH SIDES)

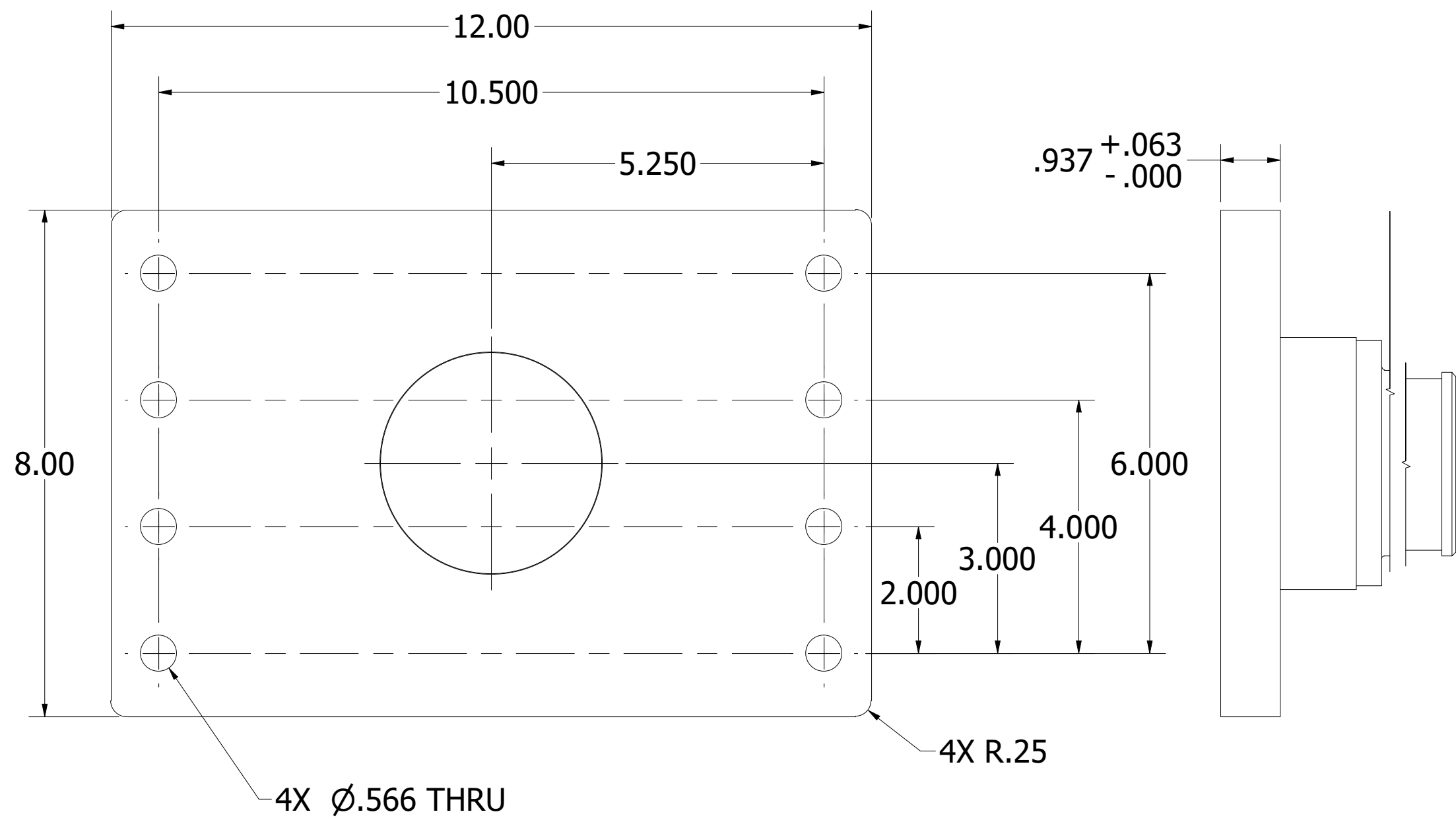

P12/B30 PAYLOAD INTERFACE

(WITH STANDARD BOLT HOLE PATTERN AND MACHINED MOUNTING SURFACE)

(TYPICAL BOTH SIDES) ANGLE MATERIAL: 6061-T6 ALUMINUM

FINISH: HARD ANODIZED

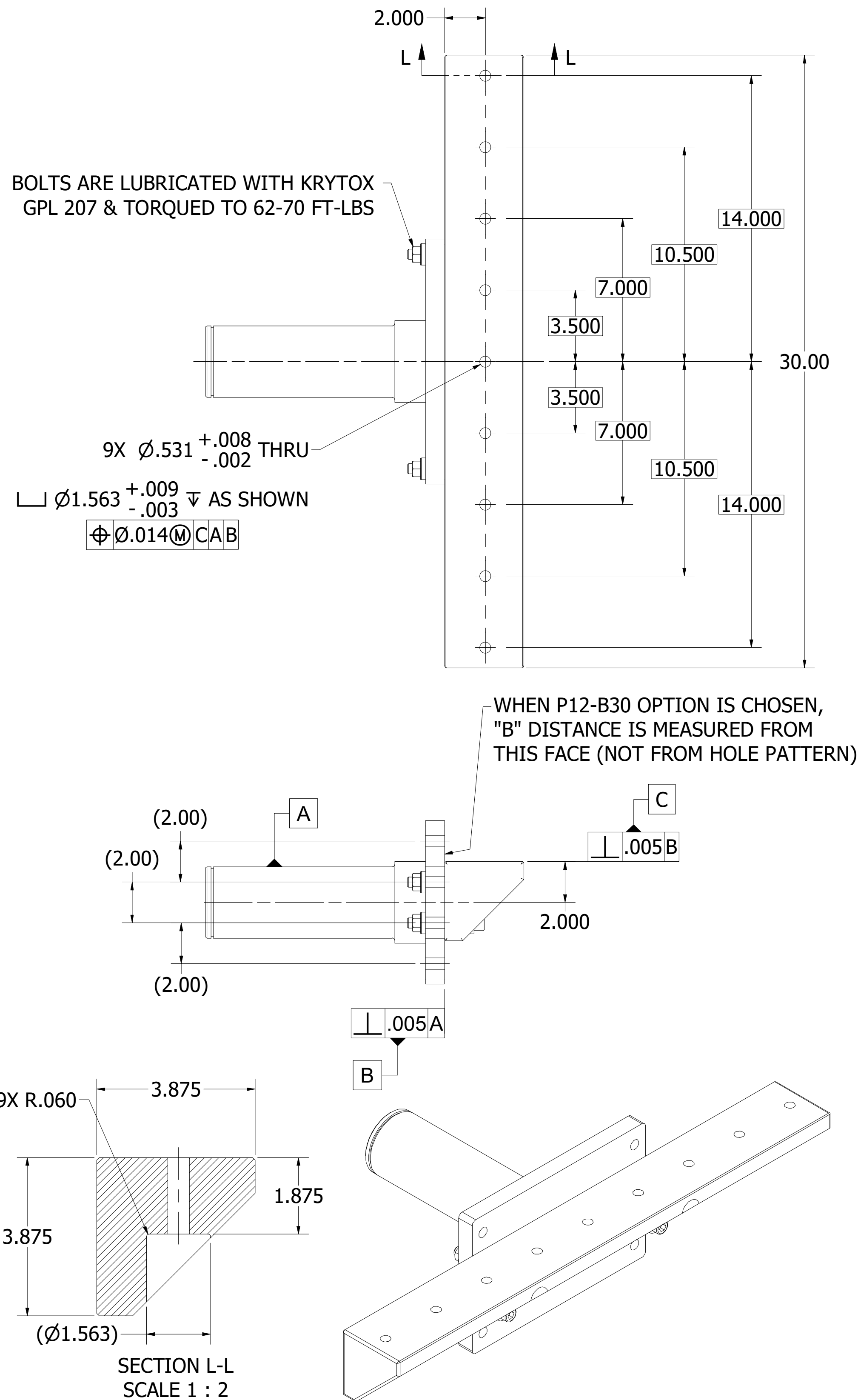

P12/A30 PAYLOAD INTERFACE

(WITH MACHINED MOUNTING SURFACE & NO PRE-MACHINED HOLE PATTERN)

(TYPICAL BOTH SIDES) ANGLE MATERIAL: 6061-T6 ALUMINUM

FINISH: SINCE POST MACHINING IS REQUIRED, ANGLE IS CHEM FILMED

(OTHER NON-STANDARD LENGTH ANGLES AVAILABLE UPON REQUEST)

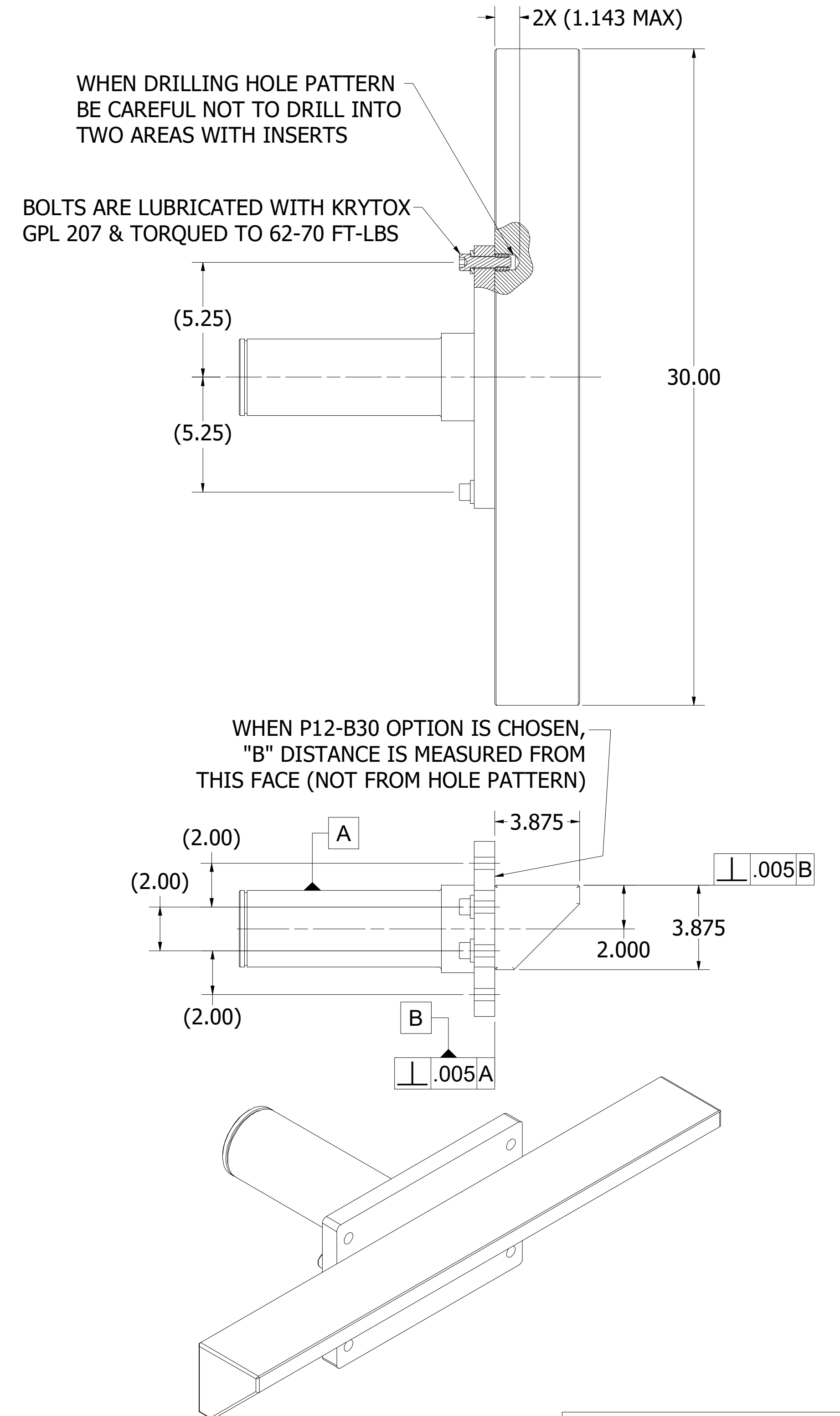

This Drawing is the property of FLOTRON, Inc. and is not to be used, copied or reproduced in any way other than for the particular purpose for which it is provided, and when said purpose has been fulfilled, it should be destroyed or returned to FLOTRON, Inc.

		2630 PROGRESS STREET VISTA, CALIFORNIA 92081 http://www.flotron.com	
SCALE	SIZE	DRAWING NO.	SHEET
1 : 8	D	8053-000PROP	8 OF 9

TOW HARDWARE OPTIONS

(T1) REMOVEABLE TOW RING INSERT

OPTION INCREASES OAL OF FIXTURE BY 10.5" (3" WHEN REMOVED)

11.19 MAX SHOWN (**STANDARD** Ø6" CASTERS)
TO
3.19 MIN (**STANDARD** Ø6" CASTERS)
13.82 MAX (Ø8" **C1** CASTERS)
TO
5.82 MIN (Ø8" **C1** CASTERS)

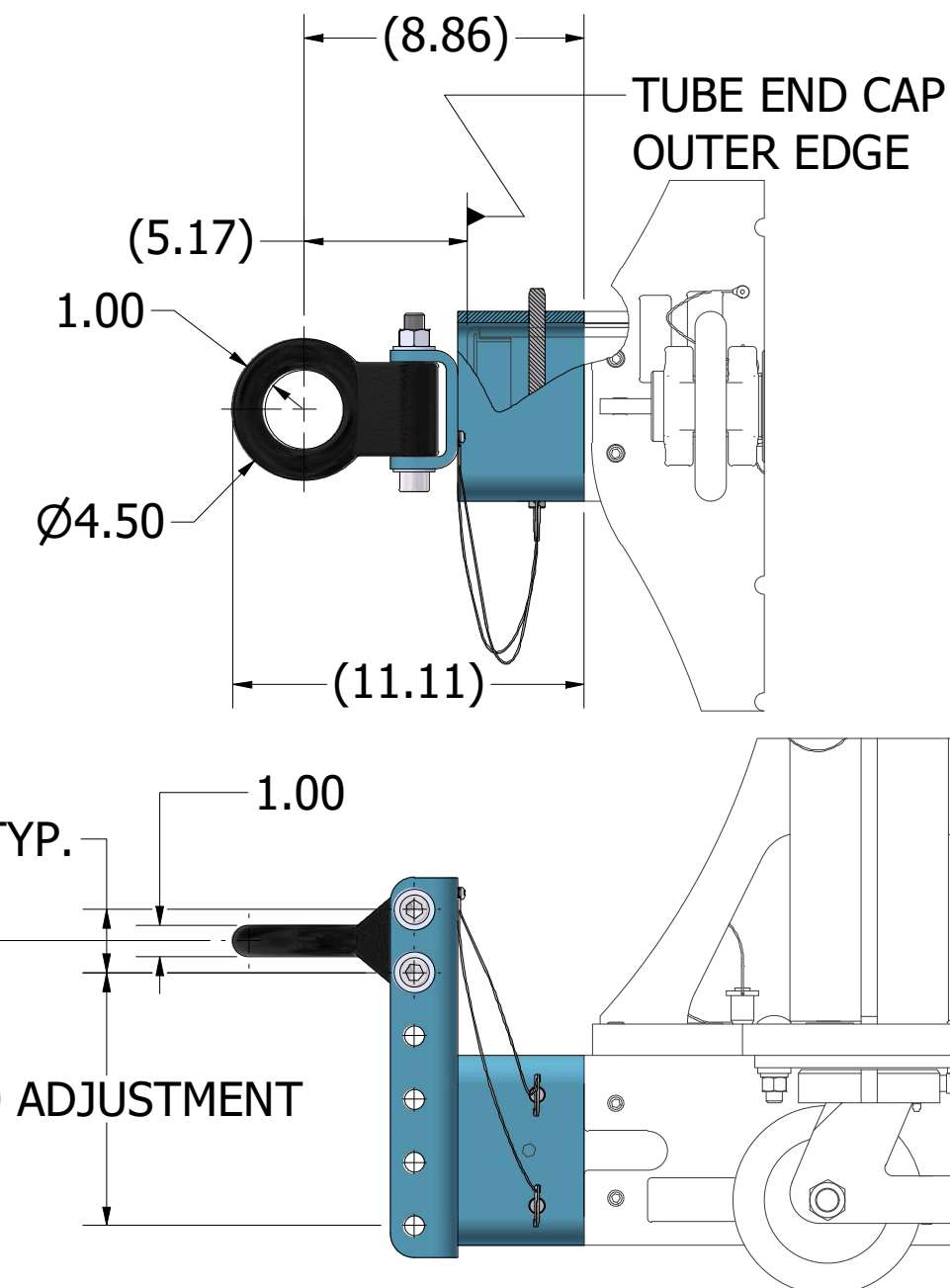

(T2) REMOVEABLE TOW BALL INSERT

OPTION INCREASES OAL OF FIXTURE BY 13" (3" WHEN REMOVED)

11.94 MAX SHOWN (**STANDARD** Ø6" CASTERS)
TO
3.94 MIN (**STANDARD** Ø6" CASTERS)
14.57 MAX (Ø8" **C1** CASTERS)
TO
6.57 MIN (Ø8" **C1** CASTERS)

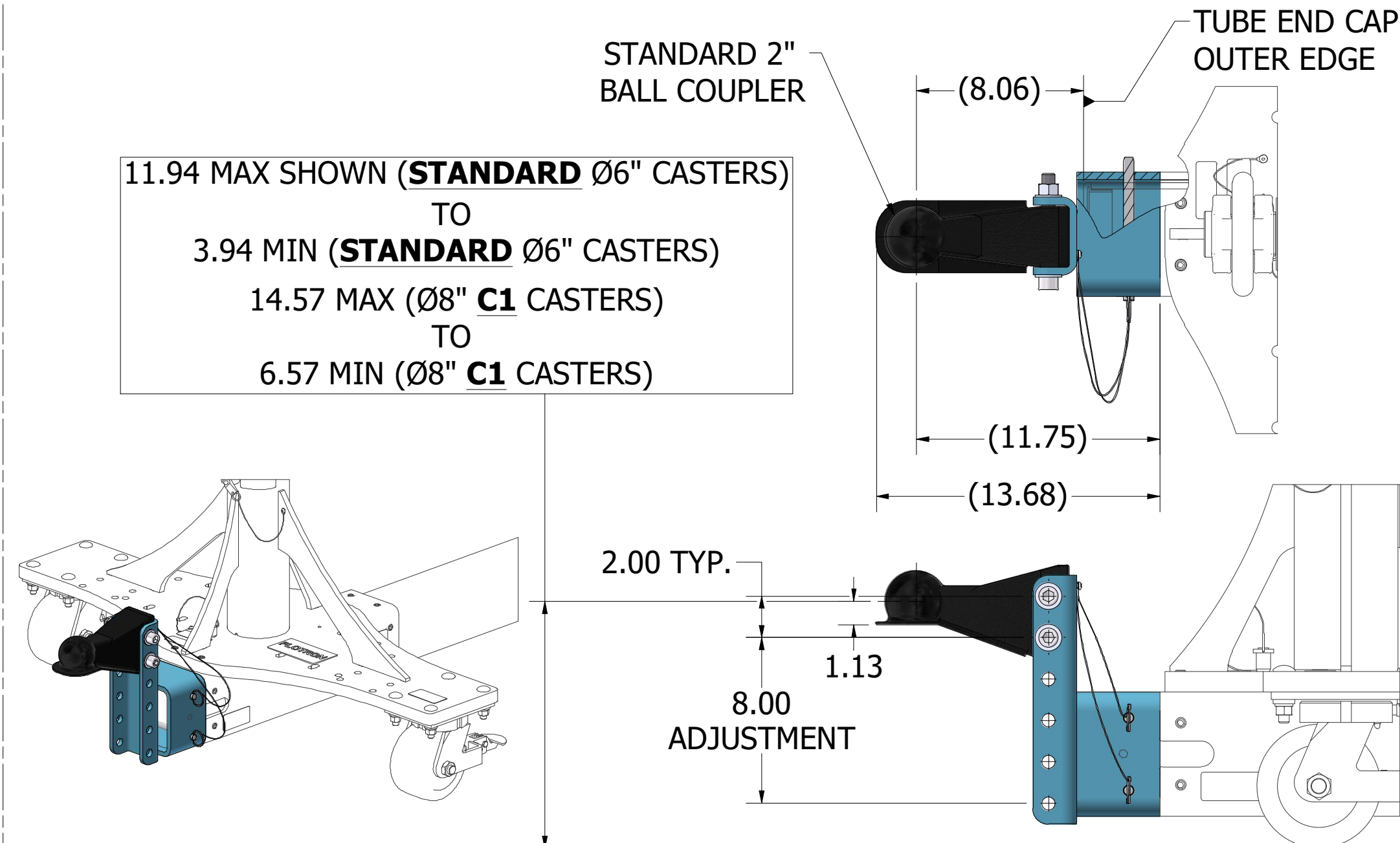

(T3) REMOVEABLE TOW BAR

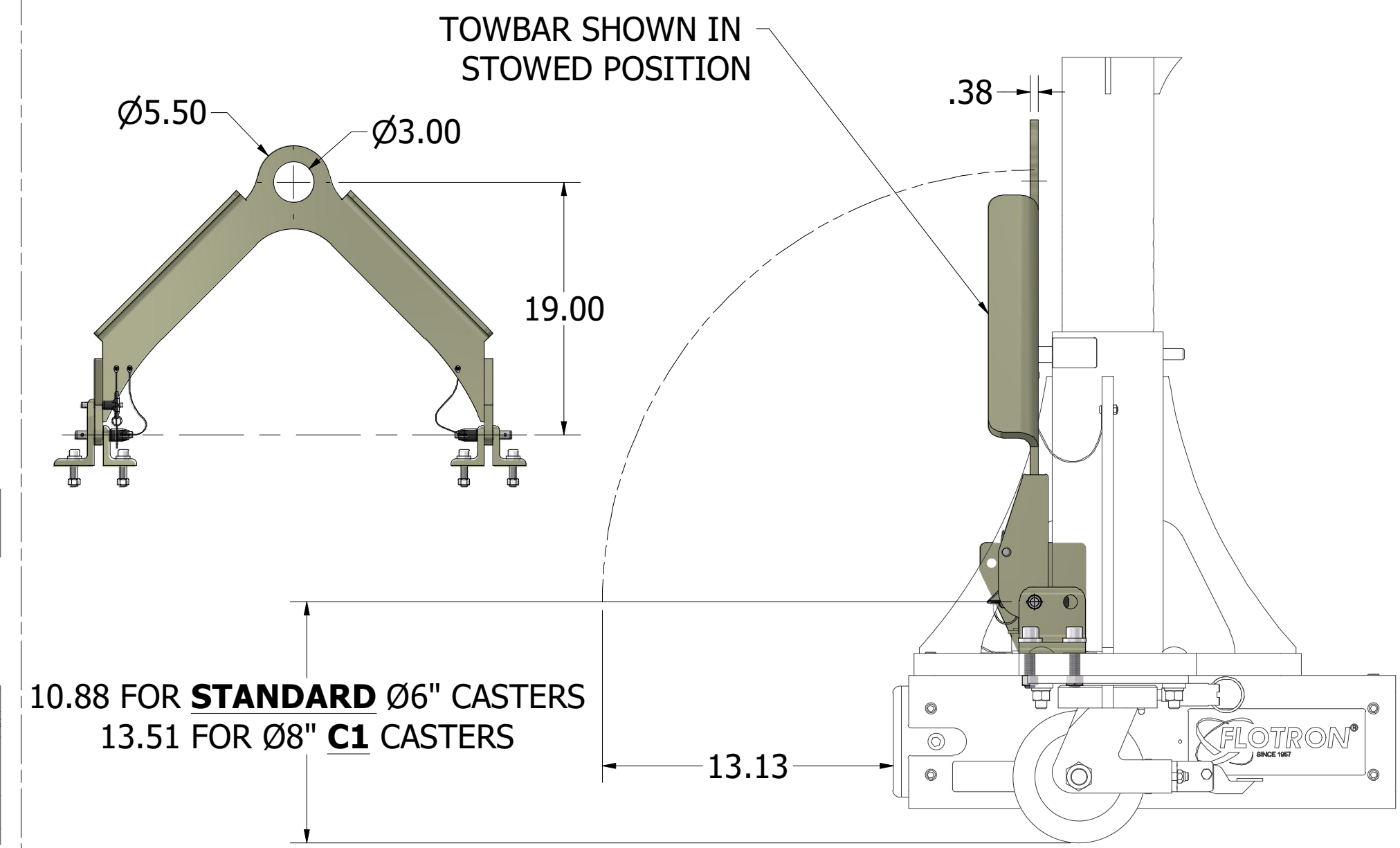

STATIC PROOF LOAD TEST (PLT) REQUIREMENTS:

PRIMARY AXIS PROOF LOAD REQUIREMENTS

1. PROOF LOAD WEIGHT = 2 X 3,200 LBS = **6,400 LBS**
2. 100% RATED TORQUE = **12,000 IN-LBS**

STATIC PROOF LOAD TEST PROCEDURE (DO **NOT** ROTATE LOAD):

1. VERIFY THAT ALL STRUCTURAL COMPONENTS HAVE BEEN PROPERLY ASSEMBLED AND ALL BOLTS HAVE BEEN TORQUED.
2. WEIGH PROOF LOAD TO MAKE SURE IT MEETS REQUIREMENT AND TAKE A PICTURE OF PROOF LOAD ON SCALE WITH LOAD VALUE ON SCALE VISIBLE FOR PROOF LOAD REPORT.
3. WHILE SUPPORTING PROOF LOAD WEIGHT TORQUE PROOF LOAD MOUNTING BOLTS THEN SLOWLY OFFLOAD PROOF LOAD WEIGHT ONTO FIXTURE.
4. STOP AS REQUIRED TO REVIEW AND INSPECT ANY UNEXPECTED NOISES OR MOVEMENTS.
5. START TIMER AND TAKE A PICTURE OF TIMER. HOLD FOR (5) FIVE MINUTES. AFTER 5 MINUTES VISUALLY INSPECT FOR CRACKS, DEFORMATION, ETC. TAKE ANOTHER PICTURE OF TIMER.

IF JACK (J2) OPTION IS CHOSEN:

1. LOWER ALL JACKS TO CONTACT THE FLOOR WITHOUT COMPLETELY OFFLOADING WEIGHT FROM CASTERS.
2. AT ONE JACK LOCATION, EXTEND JACK TO RAISE CASTER 1/2" FROM FLOOR.
3. REVIEW THE REMAINING JACK POSITIONS AND DOCUMENT CLEARANCE TO FLOOR IF ANY.
4. EXTEND THE PARTNER JACK MOUNTED ON THE SAME END FRAME TO RAISE THE CASTER 1/2" FROM FLOOR LEVEL.
5. FOLLOW THE PROCEDURE ON THE OPPOSITE END FRAME.
6. START TIMER AND HOLD FOR (5) FIVE MINUTES. AFTER 5 MINUTES VISUALLY INSPECT FOR CRACKS, DEFORMATION, ETC.

SECONDARY AXIS PROOF LOAD REQUIREMENTS (IF SA OPTION IS CHOSEN):

1. PROOF LOAD WEIGHT = 2 X 2,500 LBS = **5,000 LBS**
2. 100% PRIMARY AXIS RATED TORQUE = **12,000 IN-LBS**
3. 100% SECONDARY AXIS RATED TORQUE = **10,000 IN-LBS**

SECONDARY AXIS PROOF LOAD TEST PROCEDURE (ROTATES LOAD 90°):

1. VERIFY THAT ALL STRUCTURAL COMPONENTS HAVE BEEN PROPERLY ASSEMBLED AND ALL BOLTS HAVE BEEN TORQUED.
2. WEIGH PROOF LOAD TO MAKE SURE IT MEETS REQUIREMENT AND TAKE A PICTURE OF PROOF LOAD ON SCALE WITH LOAD VALUE ON SCALE VISIBLE FOR PROOF LOAD REPORT.
3. WHILE SUPPORTING PROOF LOAD WEIGHT TORQUE PROOF LOAD MOUNTING BOLTS THEN SLOWLY OFFLOAD PROOF LOAD WEIGHT ONTO FIXTURE.
4. STOP AS REQUIRED TO REVIEW AND INSPECT ANY UNEXPECTED NOISES OR MOVEMENTS.
5. START TIMER AND TAKE A PICTURE OF TIMER. HOLD FOR (5) FIVE MINUTES. AFTER 5 MINUTES VISUALLY INSPECT FOR CRACKS, DEFORMATION, ETC. TAKE ANOTHER PICTURE OF TIMER.
6. ROTATE PROOF LOAD 90°, START TIMER AND TAKE A PICTURE OF TIMER. HOLD FOR (5) FIVE MINUTES. AFTER 5 MINUTES VISUALLY INSPECT FOR CRACKS, DEFORMATION, ETC. TAKE ANOTHER PICTURE OF TIMER.

DELIVERABLE REPORT REQUIRED. IT MUST INCLUDE:

- A) A SUMMARY OF THE TEST PROCEDURE
- B) A PICTURE OF THE ACTUAL MEASURED WEIGHT OF PROOF LOAD ON SCALE. WEIGHT MUST BE EQUAL TO OR HIGHER THAN REQUIRED WEIGHT.
- C) PICTURE OF TIMER WITH PROOF LOAD THAT SHOWS 5 MINUTES OR LONGER FOR EACH TEST.
- D) VISUAL INSPECTION RESULTS

SFP-862 Dynamic Loading (1.0 G Vertical & 0.5 G Horizontal)

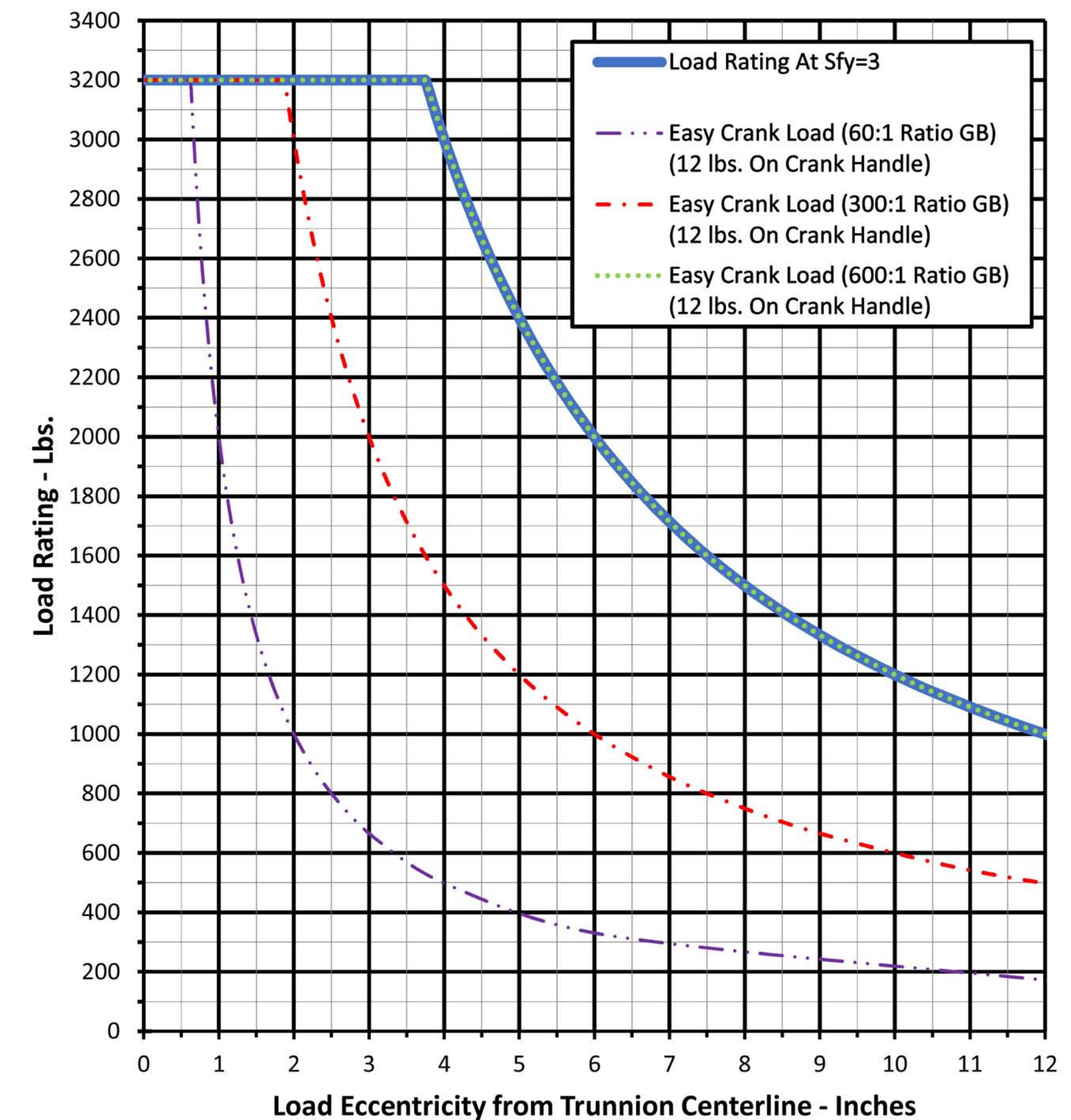

This Drawing is the property of FLOTRON, Inc. and is not to be used, copied or reproduced in any way other than for the particular purpose for which it is provided, and when said purpose has been fulfilled, it should be destroyed or returned to FLOTRON, Inc.